

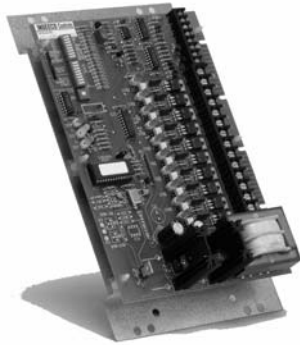

www.indeeco.com

S95 Series Step Controls



201 Series



202 Series



204 Series



205 Series

Operation

The S95 Series step controls can be used to replace earlier models of M72 Series, S71 Series, S81 Series and S92 Series step controls. Contact the factory for additional information and cross-referencing. Common applications are HVAC duct heaters, process air heaters and boilers.

Features include status leds and diagnostics. A test mode will cycle the selected stages, testing the load wiring, contactors and stage operation.

A vernier control is available, which results in more precise control than is possible with a standard step control. A separate power controller provides proportional control (0-100% load), in between the switching of step control stages.

Two different control modes and switching schemes can be selected, per the following:

Specifications

UL Recognized: File E52105 Guide XAPX2
Storage Temp: 0° to 186°F
Operating Temp: 0°F to 167°F
Line Voltage: 120/240VAC +/-10%, 12VA max
Frequency: 47 to 63 Hertz
Input Impedance: 250Ω (mA), 33KΩ (VDC)
Input Wire Range: 18-22 AWG, copper only
Input Quick Connects: 0.25" x 0.032" male

Dead Band Control: Typically used by older model step controls. When the input signal is within the input range, the stages do not change. Above the input range, stages are added. Below the input range, stages are removed.

Proportional Control: The total number of stages ON, including the optional vernier stage, is linear with respect to the input range. For example, a 5.0VDC signal to a 0-10VDC input will result in half of the stages being ON. The vernier control operates 0-100% between stages.

Progressive Switching: Even wear on stages is achieved by turning ON stages 1 to 10 in order, then starting over with stage 1. When removing stages, the first stage ON is the first stage OFF.

Linear Switching: Stage 1 is the first stage to be turned ON and the last stage turned OFF. For example: 1,2,3,4,5 ON then 5,4,3,2,1 OFF.

Stage Outputs: Pilot-duty triacs
Stage Ratings: 120/240VAC, 90VA max
Stage Terminal Block: 12-22 AWG, copper only
Stage Quick Connects: 0.25" x 0.032" male
Selectable Time Delay: 5 seconds - 10 minutes
Vernier Output: 12VDC pulse, 0.5 VA max.
Slaves Allowed: 1 per 10 stage master
Slave Cable: 30" ribbon-cable, supplied with unit

Catalog and Part Numbers: 201 & 204 Series

2 0 1 - S 9 5 - M 1 0 - 2 E

Mounting & Series	Type	Terminals	Input Code
201 = metal plate 204 = NEMA 1 enclosure	M = master S = slave	2 = terminal blocks	A = 2200 ohm C = 135 ohm E = 4-20mA L = 0-10VDC V = adjustable VDC blank = slave
Typically used for new products and to replace earlier models of M72, S71, S81 and S92 Series.	Stages		
	05 = 5 stages 10 = 10 stages		

Note: Standard masters have 4 field-selectable inputs: A, C, E and L (S input code).
The input code determines the switch position before shipment from the factory.

Catalog and Part Numbers: 202 Series

2 0 2 - S 9 5 - M 1 0 - 2 S - I

Mounting & Series	Type & Stages	Terminals	Control
Six snap-in nylon standoffs. Typically used in INDEECO electric duct heaters and process air heaters.	M = master S = slave 05 = 5 stages 10 = 10 stages	2 = terminal blocks 1 = QC (obsolete)	I = fixed for linear and proportional, regardless of dip switch setting.
	Input Code		
		S = (see note)	

Note: Masters have selectable inputs: A (2200 ohm), C (135 ohm), E (4-20mA), L (0-10VDC)
Slaves do not have an input nor control code.

Catalog and Part Numbers: 205 Series

2 0 5 - S 9 5 - M 1 0 - 2A - 21

Mounting & Series	Type	Terminals	Temperature Range
NEMA 1 enclosure with setpoint adjuster in lid.	M = master	2 = terminal blocks	21 = 0-100 F 41 = 50-150 F 43 = 50-180 F 47 = 100-210 F 51 = 120-250 F 55 = 150-250 F
Requires 310 Series thermistor sensor.	Stages	Input Code	
	05 = 5 stages 10 = 10 stages	A = 2200 ohms	

INDEECO CONTROLS
425 Hanley Industrial Ct
St Louis, MO 63144

phone: 314-644-4300
fax: 314-644-5332
www.indeeco.com

Setup and Diagnostics

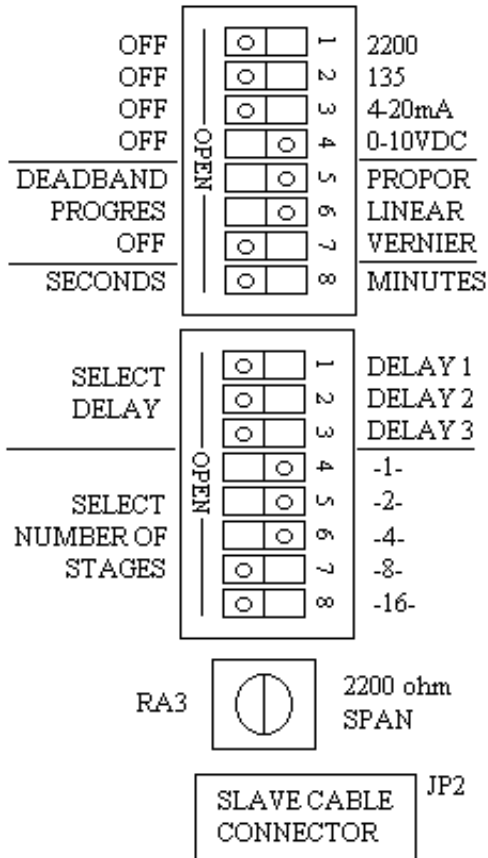

- POWER (RED)
- ERROR (YELLOW)
- SMI (GREEN)

CONTROL MODE JP1 TEST MODE

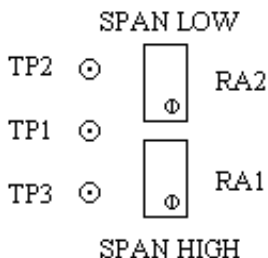

WARNING: Remove 120/240 VAC power to the step control and stages before changing any settings. Changes take effect when power is restored.

- 1) Turn on 1 of 4 inputs. Set remaining inputs to OFF.
- 2) Select DEADBAND or PROPORTIONAL control.
- 3) Select PROGRESSIVE or LINEAR switching.
- 4) Select the VERNIER control mode if the optional power controller is used, otherwise set to OFF.
- 5) Select the time delay between stages (see table).
- 6) Select the number of stages by adding up the total. For example, 10 stages would be -2- and -8-.
- 7) Potentiometer RA3 is used for 2200 ohm inputs only. The span can be adjusted from +/- 200 ohm (fully clockwise) to +/- 20 ohms (fully counter-clockwise).

Delay in Seconds	Switch Set To:			Delay in Minutes
	Delay 1	Delay 2	Delay 3	
5	No	No	No	1
10	Yes	No	No	2
15	No	Yes	No	3
20	Yes	Yes	No	4
30	No	No	Yes	5
40	Yes	No	Yes	7
50	No	Yes	Yes	9
60	Yes	Yes	Yes	(1 sec)

The POWER led is ON when 120/240VAC power is applied to the control. The ERROR led is ON when the input or stage switches are set incorrectly or jumper JP1 is set for test mode (see *Operation*). When JP1 is set to control mode, the step control functions normally. The SMI led is OFF when the input signal is below the input range and ON when above the input range. It flashes when the input signal is within the selected input range. Individual STAGE leds (not shown) are ON when the triac output is energized.

Units with the V input code have an adjustable 0-10 VDC input range. Attach a DC voltmeter to TP1 (-) and TP3 (+). Adjust RA1 to the upper VDC range. Move the meter from TP3 (+) to TP2 (+). Adjust RA2 to the lower VDC range. The HIGH input range must be at least 2.0VDC greater than the LOW input range.

Physical Dimensions: 201 Series mounting holes match older S71 & M72 Series.

**201 Series
metal mounting plate**



**202 Series
nylon standoffs**

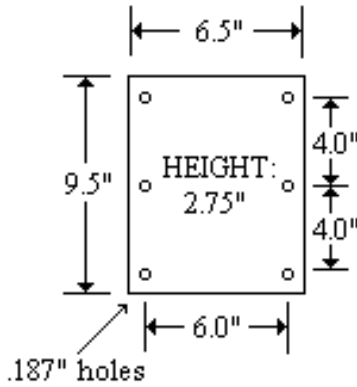

**204/205 Series
NEMA 1 enclosure**

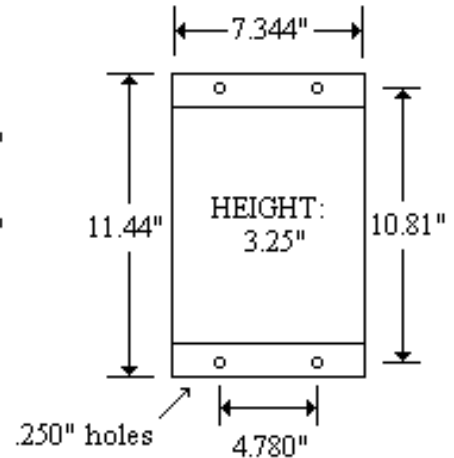

Wiring Diagram: Outputs



Wiring Diagrams: Inputs

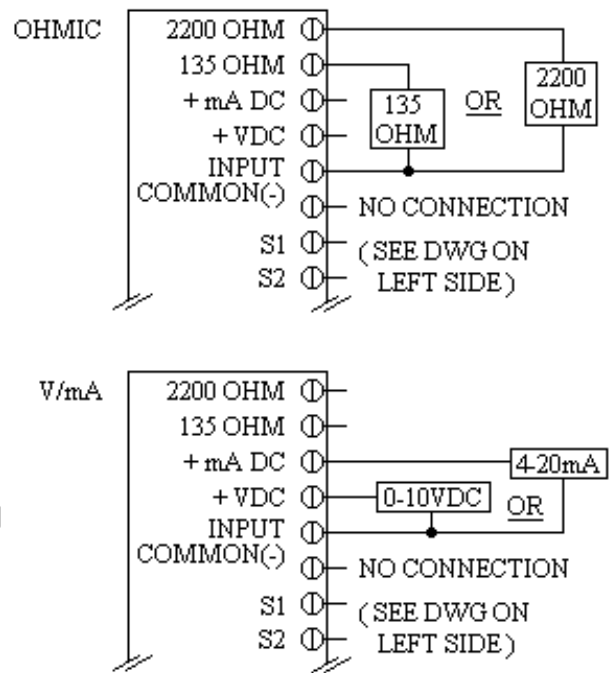

INDEECO CONTROLS
425 Hanley Industrial Ct
St Louis, MO 63144

phone: 314-644-4300
fax: 314-644-5332
www.indeeco.com