

Features:

- **Proportional Control:** Output is controllable from 0-100% of rated load.
- **Multiple Input Board:** Multiple input board allows the unit to be easily switched in the field between four standard control inputs.
- **High Ambient Rating:** Units are rated up to 168° F ambient..
- **Fail Safe Circuitry:** Output is "OFF" if input leads are shorted or opened.
- **Isolated Heatsink:** Heatsink is electrically isolated from line voltage.
- **Function Indicator:** An LED indicator allows easy monitoring of system operation.
- **Transient Absorbers:** All units are equipped with transient/surge absorbers (MOVs).

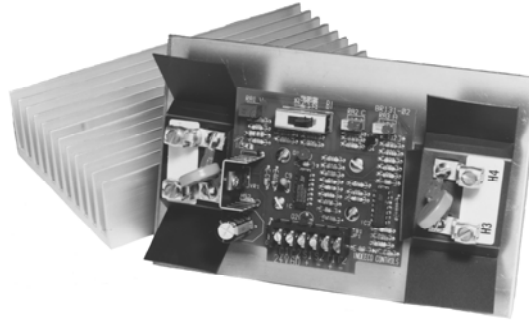

Series 103 Power Controllers

Zero Cross Fired Power Controllers

Up to 50 amps,
1 & 3 Phase,
600 VAC

- **Snubber Network:** Protection against false firing is provided by means of a snubber network across the semiconductors.
- **Optical Isolation:** Control circuit is optically isolated from the power circuit up to 4000 Vrms.
- **Vernier Control:** Slave units can be used with sequencers to obtain full vernier control.

Operation:

Series 103 power controllers are solid state, proportional switching devices. Employs semiconductor control modules to switch the power. These devices are plate mounted with external finned heat sinks that have been factory tested for operation in higher than normal ambient temperatures. The heat sink is electrically isolated from line voltage.

Zero Cross Firing: Power controllers are switched "ON" and "OFF" just as the AC sine wave crosses the zero crossover point. Using a zero voltage switching system virtually eliminates Electromagnetic (EMI) or Radio Frequency Interference (RFI), which could otherwise affect nearby equipment. The power controller's logic circuit provides proportional control using a time base interval of one second. The load is energized for a percentage of each interval, depending on the amount of power required. At the beginning of each interval, the logic circuit analyzes the input signal from the sensor or process controller and determines how many AC cycles are required to supply the correct

amount of power. An internal power supply provides low voltage, current limited power for the logic and control circuits which are optically isolated from the high voltage circuits.

Master and Slave Units: Slave units contain only the trigger and power circuits. The control signal for the slave is derived from the master unit. Only the master unit needs to receive the input signal.

Figure 1
ZERO CROSS FIRING

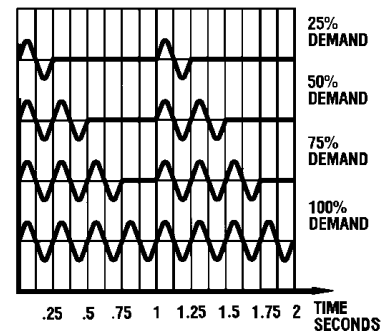

CURVE SHOWN TO REFLECT THE PERCENTAGE OF CYCLES ON IN A 1 SECOND INTERVAL (TIME BASE). FOR EXAMPLE, WHEN THE DEMAND IS 50%, 30 CYCLES WILL BE ON AND 30 CYCLES OFF (AT 60HZ).

Specifications:

Control: Zero cross switched time proportional power control with one second time base.

Ambient Temperature Range:

Shipping: -20°F to 190°F

Installation: 0°F to 168°F (circuit board)
0°F to 80°F (heat sink)

Electrical Ratings:

Line Voltage:

Nominal ratings (VAC) 240, 480, 600

Input Line voltage (VAC) 80 to 240, 80 to 480, 80 to 600

Control Voltage:

All units require a 24 VAC, 10 VA minimum power to the circuit board. This circuit must be provided by an approved class 2 transformer.

Phase: Single and three phase

Frequency: 50 or 60 HZ

Amps: 10, 20, 30, 40 and 50 amps

Control Signal Isolation: 4000 Vrms from input to output and 2500 Vrms from input/output to ground.

Wiring Connection: 3-48 screw type terminals for control wiring and box lug connectors suitable for 6-18 AWG copper power wiring. One pair of box lug connectors are provided for single phase units which provide control by breaking one leg of a single phase circuit. Two pairs of box lug connectors are provided for three phase units which provide control by breaking two legs of a three phase circuit.

Inputs: Please specify the input code when ordering so that the input board can be factory set for that input.

Table 2: Standard inputs and Spans:

Code	Input	Span
*A	2200 ohms	100 ohms
B	1700 ohms	100 ohms
*C	135 ohms	100 ohms
D	6-9 ohms	2.4 VDC
*E	4-20 mA	12.8 mA
G	Potentiometer	100 ohms
H	0-5 VDC	4.0 VDC
K	2-10 VDC	6.4 VDC
*L	0 - 10 VDC	8.0 VDC

* Power Controller ordered with any one of these inputs will be shipped with a multiple input circuit board that can be easily switched between four standard inputs. Other inputs are special.

Electrical Connections: All electrical connections should be in accordance with the National Electrical Code and other applicable local codes. See wiring diagrams below for typical connections. In all cases, 24 VAC power for the control circuit is connected to L1 and L2 terminals, sensor input is connected to T1 and T2 terminals and Slave driver output is connected to S1 and S2 terminals.

CAUTION: Power Controller may be damaged if it is connected to an input device which has a common connection between L2 and T2 or if polarity on all connections is not observed.

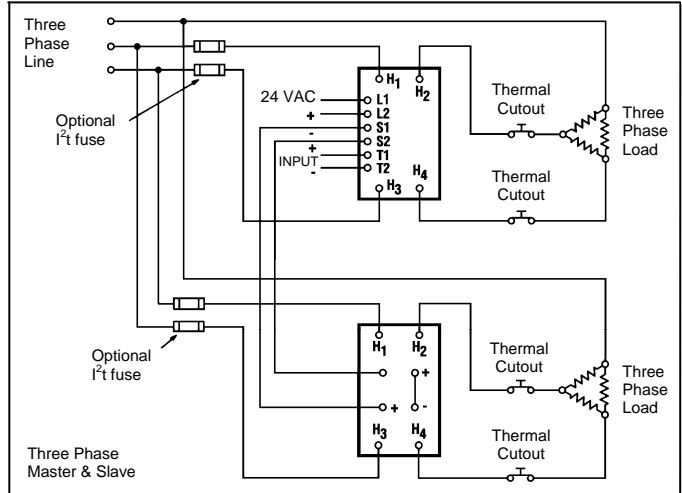
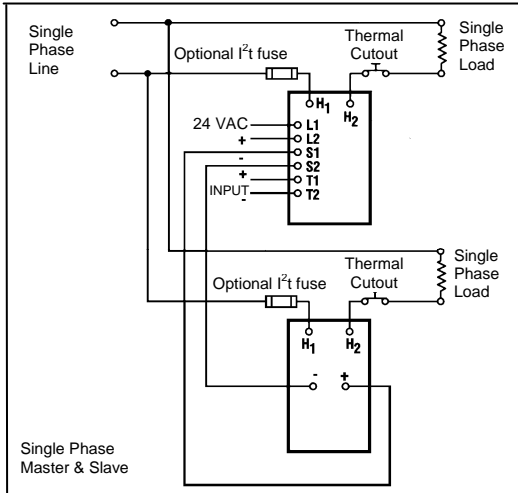
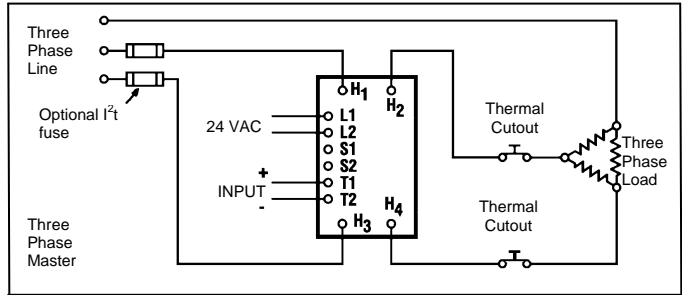
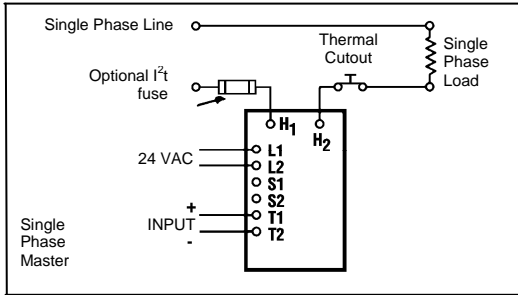

How To Order:

(Product Code)

1 0 3 A 1 2 4 0 3 0 E

SERIES
A1 – Single Phase Master
B1 – Single Phase Slave
A3 – Three Phase Master
B3 – Three Phase Slave

INPUT CODE

A-2200 Ohm	H- 0-5 VDC**
B-1700 Ohm	K- 2-10 VDC**
C- 135 Ohm	L- 0-10 VDC**
D- 6-9 VDC**	
E- 4-20 Milliamps*	* 250 Ohm Impedance
G- Potentiometer	** 33 K Ohm Impedance

VOLTAGE⁽¹⁾
240, 480 or 600 VAC

AMPS
10, 20, 30
40 or 50 Amps

NOTES

⁽¹⁾ Can be used at any voltage up to the maximum specified voltage.

INSTALLATION, SETUP AND TROUBLE SHOOTING GUIDE FOR 103 SERIES POWER CONTROLLERS (CONTROL CIRCUIT BOARD TYPES BI OR BS)

CAUTION

INSTALLATION OF THIS EQUIPMENT SHOULD BE DONE ONLY BY QUALIFIED PERSONNEL WITH ALL ELECTRICAL POWER DISCONNECTED AND IN ACCORDANCE WITH ALL LOCAL AND NATIONAL CODES.

ELECTRICAL: (See figures 5-8)

All electrical connections should be made in accordance with the NEC and applicable local codes and ordinances. Sensor wiring up to 300 feet long needs no special consideration. Sensor wiring over 300 feet long should be two wire shielded cable. Shielding must be earth grounded on one end. **Polarity of all electrical connections must be done as shown below in Fig. 9. Failure to do so could damage the unit.**

ALL START-UP AND FIELD CALIBRATION INSTRUCTIONS ARE FOR 103 SERIES MASTER UNITS ONLY. SLAVE UNITS DO NOT REQUIRE ANY CALIBRATION AND THEY ARE "ON" WHEN EVER THE MASTER UNITS ARE "ON".

FIELD START-UP:

Caution: Check to make sure that input switch position is set properly for your sensor input per Table 1 below. If it is not the same, see instructions on how to change inputs in the next paragraph.

1. All wiring should be completed per equipment manufacturer's wiring diagram and insure correct thermostat or specified input signal is being used. Use of incorrect voltage signal or use of ON/OFF type thermostats could cause damage to the circuit boards.
2. Set thermostat or the sensor input to minimum setting.
3. Turn ON 24 VAC to the circuit board and high voltage to the power controller terminals (H1 & H2 for 1 phase units and H1, H2, H3 & H4 for 3 phase units). Power controller should remain OFF. (LED should not light.)

NOTE: This step assumes that the controlled area temperature is greater than the minimum setting of the thermostat.

4. Turn the thermostat or the sensor input up slowly until the power controller begins to modulate. This should occur slightly above the minimum point of the sensor input span. (For example, on units with 4-20 mA input, this occurs around 5.4 mA.) Continue to increase the sensor input until the unit cycles 50/50 with the input set approximately at the middle of the input span. (For example, on units with 4-20 mA input this occurs around 12mA). If the unit does not cycle 50/50 at this point, it may be out of calibration. This may be corrected by calibrating your input device.
5. Increase the thermostat setting or the sensor input to the maximum point of the sensor input span. The unit should stay full ON. (For example, on units with 4-20 mA input, this occurs around 18.4 mA.)
6. Set the thermostat or sensor input at the required setting. After initial heating, the power controller will stay in a modulating condition. If the unit does not perform as required, see trouble shooting guide on the other side.

CHANGE OF INPUT:

CAUTION: Use this procedure only if your sensor input is different from what the unit is calibrated for as shown on the sensor input label or if the switch is in the wrong position.

No calibration is required for units with a potentiometer input (input code G) except to check that the unit is fully OFF with the Potentiometer set all the way to the left, full ON with the potentiometer set all the way to the right and is modulating 50/50 with the potentiometer at the middle of the scale.

This procedure makes specific reference to the monitoring of the LED (light emitting diode) on the controller circuit board. While the LED shows control status, it does not explicitly indicate the operation of the Power Controller or a completed heater circuit. It is recommended that either voltage or current readings be taken at Terminals H1 and H2 (single phase), or terminals H1, H2, H3 and H4 (three phase). These outputs should act identical to the LED indicator.

1. Check and make sure the switch position is set properly on the circuit board per Table 1 for your sensor input. Check the label on the circuit board to see if the board you have is of type "BI" or "BS". See Fig. 9 for the location of the switch. Please contact INDEECO Controls if your sensor input is not listed in Table 1.
2. Check to insure that the proper load resistance is present at Terminals H1 and H2 (single phase) or Terminals H1, H2, H3 and H4 (three phase).

- Caution: Take ohmmeter measurements only with the power off.**
3. Connect a variable resistor for ohmic inputs or a variable DC voltage power supply for all other inputs across Terminals T1 and T2. Please make sure the positive lead (+) is connected to Terminal T1 and the negative lead (-) is connected to Terminal T2. Apply 24 VAC to the circuit board at L1 and L2 terminals. (24 V and GD)

TABLE 1

INPUT	SWITCH POSITION		VALUE FOR 50/50 CYCLING
	BOARD TYPE		
	BI	BS	
2200 OHMS	4	1	2200 OHMS
135 OHMS	1	-	67 OHMS
4-20 mA	3	3	12 mA
0-10 VDC	2	2	5 VDC
6-9 VDC	-	4	7.5 VDC
POTENTIOMETER		1	MIDDLE OF SCALE

Figure 9

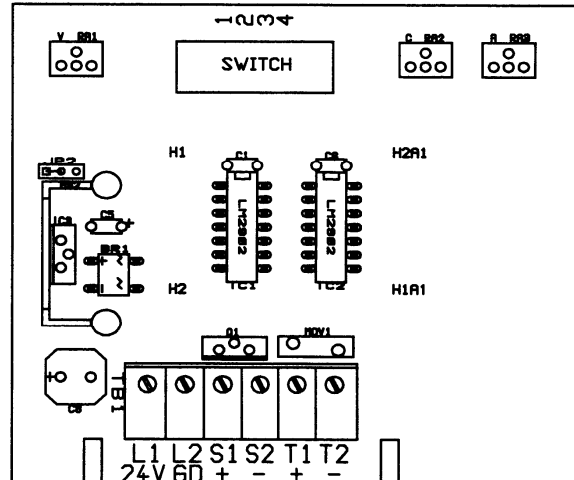

CHANGE OF INPUT CONT.:

- Set the value of the input to the value given in the last column of table 1 for the sensor input you have. Observe the LED. It should be cycling at approximately half ON and half OFF. (50/50)
- Decrease the value of the input slowly and observe the LED. The percentage of ON time should continually decrease until the input value reaches the low end of the input span. At this time the LED should be fully OFF.
- Increase the value of the input slowly and observe the LED. The percentage of ON time should continually increase until the input value reaches the high end of the input span. At this time the LED should be fully ON.
- Open input test:** Remove one input lead (terminal T1). The LED should go OFF.

SLAVE UNITS:

Up to four slave units can be connected to a single master. Slave units may be tested either in conjunction with master controllers or independently. When wired as illustrated in Figures 6 and 8, their behavior should be identical to the master unit. (There is no LED on the slave units. Their operations have to be verified by checking the voltage on the load side).

To individually test a slave, the following procedure may be used:

- Check to insure that the proper load resistance is present at Terminals H1 and H2 (single phase) or Terminals H1, H2, H3 and H4 (three phase). Caution: Take ohmmeter measurements only with power OFF.
- Apply 12 VDC to Terminals 3 and 4.
- Check the voltage at terminals H1 and H2 (single phase) and H1, H2, H3 and H4 (three phase). You should read approximately 1.5 VAC between the line terminals when the unit is ON.

TROUBLESHOOTING:

CAUTION: Disconnect all sources of power before servicing this equipment. Service must be performed by properly trained personnel. Master units are provided with an LED that indicates logic status and circuit operation. Reference to this indicator will greatly aid in uncovering problems.

In some instances, it may be necessary to remove the control circuit board. To do this, disconnect all the wiring from the terminal block and unscrew the screws holding the board down. To replace, place the circuit board carefully on the low voltage terminals and tighten the screws down.

Replacement circuit boards: To order a replacement circuit board, please give the full catalog number of the power controller and the part number from the label on the circuit board.

SYMPTOM	PROBABLE CAUSE	CORRECTIVE ACTION
LED not ON	(A) No voltage at line terminals (B) Wrong voltage at line terminals (C) Wrong or no voltage at L1 & L2 (D) Thermostat not demanding heat (E) Shorted or open sensor leads (F) Defective sensor or thermostat (G) Out of calibration (H) Defective controller	(A) Restore voltage (B) Consult factory (C) Restore correct voltage. (D) Set thermostat to higher temperature (E) Repair wiring (F) Replace (G) Recalibrate (H) Replace controller
LED ON, but no heat	(A) No Load (B) Defective controller	(A) Check Hi-limits (A1) Check load wiring (A2) Check and replace load if necessary (B) Replace controller
LED ON, but too much heat	(A) Thermostat set too high or set point set too high (B) Out of calibration (C) Defective power controller	(A) Set thermostat set point lower point (B) Recalibrate (C) Replace controller
LED OFF, but too much heat	(A) Miswired (B) Defective power controller	(A) Rewire (B) Replace controller

LIMITED WARRANTY

INDEECO Controls new products are warranted against defects in workmanship, material, design, labeling and packaging. No other warranty, express or implied, written or oral, applies. No person other than an officer or the division manager of INDEECO Controls is authorized to give any other warranty or assume any liability.

Warranty Period: This warranty is effective for eighteen months from the date of shipment of the product from INDEECO Control's factory, or for twelve months from the date the product is first placed in service, whichever period lapses first.

Conditions of Warranty: INDEECO Controls products must be installed, operated and maintained in accordance with INDEECO Control's instructions. INDEECO Controls is not liable for damage or unsatisfactory performance of the product resulting from accident, negligence, alteration, unauthorized repair, improper application or installation of the product, improper specifications, or corrosion. INDEECO Controls IS NOT LIABLE FOR ANY INCIDENTAL OR CONSEQUENTIAL DAMAGES. Claims against carriers for damage in transit must be filed by the purchaser with the carrier.

Remedy: Contact the INDEECO Controls sales department in St. Louis at (314) 644-4300 for a Return Material Authorization Number (RMA #). Return

the part or product in question, freight prepaid, and marked with your company name and the RMA # to:

INDEECO Controls
425 Hanley Industrial Court
St. Louis, MO 63144

Attention: Return Goods Manager

If after receipt of the product and the claim, INDEECO Controls finds to its reasonable satisfaction that the product is defective in workmanship, material, design, labeling or packaging, the product will be repaired or replaced or the purchase price refunded at INDEECO Control's option. There will be no charge to the purchaser for part or labor. Removal and reinstallation of the product, and shipment of the product to INDEECO Controls for repair or inspection shall be the purchaser's risk and expense.

THE REPAIR, REPLACEMENT OR REFUND PROVIDED FOR IN THIS LIMITED WARRANTY IS THE EXCLUSIVE REMEDY OF THE PURCHASER. THIS WARRANTY IS EXPRESSLY IN LEIU OF ANY OTHER INCLUDING ANY WARRANTY OF MERCHANTABILITY OR FITNESS FOR A PARTICULAR PURPOSE. THERE ARE NO WARRANTIES WHICH EXTEND BEYOND THE TERMS OF THIS LIMITED WARRANTY.