



# INSTALLATION, OPERATING & MAINTENANCE INSTRUCTIONS FOR ELECTRIC PROCESS AIR HEATERS

## GENERAL

INDEECO Process Air Heaters are designed to provide years of trouble free operation if properly installed and maintained. Please read and follow these instructions for installing and maintaining the heater.

INDEECO process air heaters are designed and intended for installations in plenums or ducts to heat forced air in industrial equipment and systems. A variety of designs and sizes are available with outlet air temperatures up to 1200°F. Due to these high temperatures, the heater design features must be closely matched to the application.

There are three types of heating elements:

- Open Coil - a bare (electrically hot) resistance wire coil
- Finned Tubular - a spiral finned metal sheathed element
- Tubular – a tubular metal sheathed element.

**Open coil elements** require clean, uniform airflow and can only be mounted with the coils horizontal. They should not be used where there could be contact with the coils by personnel or electrically conductive material.

**Finned tubular elements** can tolerate moisture and a degree of non-uniform airflow. Finned tubular elements should not be used where contaminants are likely to build up between the fins.

**Tubular elements** are universally applicable. Tubular and finned tubular process air heaters can be mounted with the elements either vertical or horizontal.

The heating elements are available in various watt density ratings. Outlet temperature, watt density and airflow velocity determine the surface temperature of the open coil, tubular or finned tubular elements. Life of the heating

element is directly related to its surface temperature. Follow the limitations of Table 1 for maximum watt densities and minimum airflows. The watt density is shown on the heater nameplate.

There are two types of heater frames:

- A sheet metal frame for slip-in duct mounting is standard for 250°F rated units (Figure 1).
- A plug-type design with mounting plate is standard for 400°F through 1200°F rated units (Figures 2 & 3).

All open coil process air heaters, and the 250°F finned tubular process air heaters, have top and bottom frames that restrict the airflow to either horizontal or vertical, while all other process air heaters can be used with any perpendicular air flow direction.

Instructions for Industrial Control Panels are provided in ENM - 2179. A section on control methods is included.

### CAUTION

Failure to follow INDEECO recommendations could result in premature failure and/or serious equipment damage.

Temperature regulating devices, temperature limiting controls, and low flow controls are recommended for use with process air heaters to control the heating process and safeguard the heater from excessive temperatures that can cause damage.

## INSTALLATION

### CAUTION

INDEECO recommends installation be performed by qualified personnel familiar with the National Electrical Code and all local codes and standards. It is the responsibility of the installer to verify the safety and suitability of the installation

### WARNING

Hazardous voltages are present in this equipment. Lock out and tag the branch circuit disconnect switch before working on this heater.

### Handling and Storage

Care must be taken to avoid damage to the heater during storage and handling. Protect the heater from weather damage during storage if shipping packaging is not sealed.

It is recommended to store the heater in a cool dry area to help prevent the heating elements or ceramic spacers from drawing moisture.

### Mechanical Instructions

#### Site Selection

Review the NEMA Type rating of the heater provided. Do not install a heater in an area not consistent with its rating.

### WARNING

DO NOT mount heaters in an atmosphere containing combustible gases, vapors, dusts, or fibers.

Allow at least three feet in front of the heater terminal box for heater maintenance. Consideration should also be given for heater removal clearance to allow heater replacement.

Electric heaters are capable of developing high temperatures. Therefore, extreme care should be taken to avoid mounting heaters in an atmosphere containing combustible gases, vapors, dusts, or fibers unless properly marked as suitable for the condition.

If the duct or plenum is insulated, be sure that insulation does not block airflow across the heating elements. Insure that the airflow is uniform across the face of the heater to

avoid hot spots. Typical causes for uneven airflow are structural components blocking air or mounting the heater too close to elbows, transitions or the fan. A pressure plate on the heater inlet should be considered if uneven airflow is expected.

The heater should be mounted plumb horizontally and vertically to assure proper operation. If the heater is installed horizontally and weighs over 25 pounds, support rails or hangers must be provided in the duct or plenum for support.

#### **WARNING**

Do not cover the heater terminal box or install the heater so that part of the terminal box is within the duct or plenum. Dangerous over-heating of the wiring could result.

#### Slip-In Duct Mounted Construction (Figure 1)

1. Determine proper mounting for airflow direction.
2. Cut a hole into the duct or plenum to accommodate the body of the heater (excluding the terminal box). The hole should be at least 1/8" larger than the frame.
3. Slip the heater into the opening, center and attach the back of the terminal box to the duct or plenum using sheet metal screws.
4. Do not mount an open coil heater with the coils in a vertical position.

#### Plug-Type with Mounting Plate Construction (Figures 2 & 3)

1. Determine proper mounting for airflow direction.
2. Cut hole into the duct or plenum to accommodate the body of the heater (excluding the mounting flange). This hole should be at least 1/8" larger than the frame.
3. Supply a mating flange, weld studs or bolt holes to match the mounting flange.
4. Supply a gasket between the mounting and mating flanges.
5. Do not mount an open coil heater with the coils in a vertical position.

### **Electrical Instructions**

The potentially high operating and ambient temperatures of process air heaters require field wiring to the heater to be carefully matched to the application to avoid serious injury or damage to the equipment. The wiring must be de-rated for the expected terminal box temperature.

The size and type of incoming field wiring will depend upon the heater terminal box temperature, heater current draw per conductor, number of conductors per conduit, and wire insulation rating. Refer to the National Electrical Code.

The terminal box temperature is directly related to the heater outlet air temperature. Insulated terminal boxes are provided on high temperature heaters to allow moisture seals on tubular and finned tubular heating elements, and to avoid costly high temperature wire. Refer to Table 2 for the INDEECO estimated terminal box temperature.

Field supplied conductors must be sized for at least 125% of the circuit current.

To calculate the circuit current (in amps):

$$\text{Single phase Line current} = \frac{\text{KW} \times 1000}{\text{Line Voltage}}$$

$$\text{Three phase Line current} = \frac{\text{KW} \times 1000}{1.732 \times \text{Line Voltage}}$$

Wiring to the heater should be permanently installed in metallic or non-metallic electrical grade conduit in accordance with all applicable electrical codes, and should include a grounding conductor if non-metallic conduit is used.

Field supply wiring must be rated for 600Vac. Use copper conductors. 450°C wire may be required on high temperature heaters. If the wire is not available locally, please contact INDEECO.

The electrical installation should include a service disconnect switch in sight of the heater as well as branch circuit over-current protection and over-temperature protection (if not provided with the heater).

For wiring recommendations refer to the wiring diagram. An additional copy is provided inside the heater terminal box.

INDEECO strongly recommends the use of an outlet air over-temperature control device located near the heater outlet. A thermostat or thermocouple (with remote controller) set approximately 50°F above the normal operating temperature may be used. Additionally, a differential pressure switch or a fan interlock relay may be used to detect air pressure or fan motor operation. This will prevent the heater from operating without airflow.

Where thermocouple extension wire is required between the heater and control panel, verify it is connected with proper polarity as shown on the wiring diagram. Failure to do so may result in an uncontrolled heater. Refer to the wiring diagram for the required wire type. Shielded wire is recommended to reduce signal interference.

#### **WARNING**

Retighten all electrical connections that may have loosened during shipment. Failure to do so may result in damage to the heater or risk of fire. (See Pg.5)

When making connections directly to the element terminals on tubular or finned tubular elements, apply a 1/4" wrench to flat sections of the element terminal immediately below the threads. Otherwise, damage to the terminal may result.

Confirm all unused conduit holes in the terminal box are sealed with plugs suitable for the heater environment.

Attach a ground conductor to the ground lug located in the heater terminal box or by other appropriate means per NEC Article 250.

Be sure the terminal box cover is properly installed at all times to ensure personnel protection. Also, contaminants can create leakage, (shock) hazards, permanent heater damage or failure and should be avoided.

It is recommended to perform an insulation resistance test prior to energizing the equipment. If the value is less than 1 Meg Ohm using a 500Vdc or similar tester, refer to Maintenance and Troubleshooting sections.

---

## OPERATION

---

To operate this heater, ensure the fan is operating, and energize the main supply disconnect. Set the controlling device to the desired temperature.

During initial heating, it is recommended to slowly ramp up the process set point and inspect the heating system for problems.

**DO NOT** operate heaters at voltages in excess of that marked on the heater. Excess voltage can shorten heater life or overload the branch circuit wiring.

**DO NOT** operate heaters at sheath temperatures higher than the recommended maximum. Excess temperatures can cause premature failure. Generally, sheath materials

are limited to 1400°F for stainless steel and 1600°F for Incoloy.

**DO NOT** operate heaters at flow rates below the design flow range. Reduced flow can shorten heater life, or cause nuisance tripping of thermal safeties. Note that heaters with SCR control can typically operate at reduced flows down to 1/10<sup>th</sup> of the design flow if the controller is properly tuned, and over-temperature safety devices are set at an appropriate point to protect the heater and fluid.

INDEECO recommends that all safety interlocks are tested during initial startup to ensure they properly disable the heater. After 10 days of operation, retighten all electrical connections.

---

## MAINTENANCE

---

### CAUTION

Troubleshooting and repairs should only be attempted by qualified maintenance personnel.

Periodically check all electrical connections, including field and factory-made connections for tightness, and all wiring for deterioration at least once a year. (See Pg.5)

Other parts of the heating system such as fans and filters, should also be periodically inspected for obstructions, proper operation, etc.

Inspect the terminal enclosure and conduit connections for evidence of water leaks or moisture collection. Tighten connections as required. Clean up any corrosion. Do not continue using a heater with signs of damage.

Where buildup of dirt or solids on the heating elements or significant corrosion is expected, periodically inspect the heating elements. Do not continue using a heater with signs of damage.

### Replacing Resistance Coils on Open Coil Heaters:

The condition of the ceramics must be considered before attempting to replace coils. Cracked or damaged ceramics must be replaced. Contact the factory before replacing any coils with damaged ceramics.

Field replaced heating coils must be installed properly or failure may occur. Sketch the coil and bussing configuration before starting, or take pictures.

Remove the burned out coil by pulling lightly, and at the same time turning the coil back and forth. Check the ceramics near the area where the burnout occurred. Burn spots should be cleaned with a dry clean paper or cloth towel. Oil or other contamination on the heater will cause a failure.

The new coil should be stretched to the correct length (do not over stretch). Lay the existing coil on a flat bench, and evenly stretch the new coil to match. String the new coil by starting at the center of the coil and working towards both ends. Lightly push with a constant back and forth turning motion. After the coil is in place, reconnect any removed bussing.

---

## TROUBLESHOOTING

---

The nature of the magnesium oxide used to electrically isolate the nickel chromium resistance wire in tubular and finned tubular heating elements, or ceramic bushings on open coil heaters, is such that over a long period of storage, they will absorb considerable moisture from the atmosphere unless hermetically sealed. It is recommended to perform an insulation resistance test prior to energizing the equipment. If the value is less than 1 Meg Ohm using a 500Vdc or similar tester, care must be taken to dry out the heater to prevent failure. It is recommended that the elements be turned on at a reduced voltage at first to boil off the moisture. Meg Ohm readings may drop initially after a few minutes of operation, indicating moisture being forced out of the elements. The terminal enclosure lid should be left open during this period to allow the moisture to escape.

If the heater has a manual-reset high limit thermostat, be sure that the reset button is pressed in.

The heating elements are not field-repairable. The only recommended field repairs are to remove and replace the faulty heating elements or coils, or to return the heater to the factory for repair.

If reduced heat output is suspected, verify the condition of the heating elements by using an ammeter to check the current draw of each input line. All input lines should draw approximately equal current, which should agree with nameplate rating. If they do not, one or more of the heating elements could be damaged.

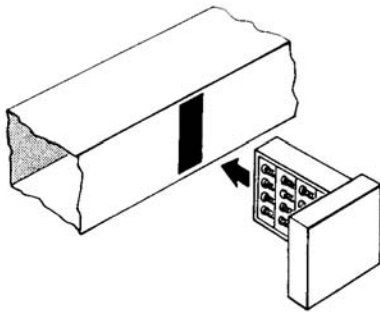
**Table 1**

MAXIMUM WATT DENSITIES AT OUTLET TEMPERATURES AND VELOCITIES SHOWN														
MINIMUM VELOCITY IN STANDARD FPM	OPEN COIL CONSTRUCTION							FINNED TUBULAR CONSTRUCTION				TUBULAR CONSTRUCTION		
	OUTLET TEMPERATURE							OUTLET TEMPERATURE				OUTLET TEMPERATURE		
	250°F	400°F	500°F	600°F	750°F	1000°F	1200°F	250°F	400°F	500°F	600°F	750°F	1000°F	1200°F
300	55	45	35	30	25	15	10	45	40	35	30	13	6	3
600	60	55	50	45	30	20	10	55	50	40	35	22	12	7
900	65	65	60	55	35	25	15	65	65	55	45	25	18	12
1200	65	65	65	65	40	30	20	65	65	60	55	30	22	16
1600	65	65	65	65	55	40	25	65	65	65	65	40	30	22
2000	65	65	65	65	65	50	30	65	65	65	65	45	35	25

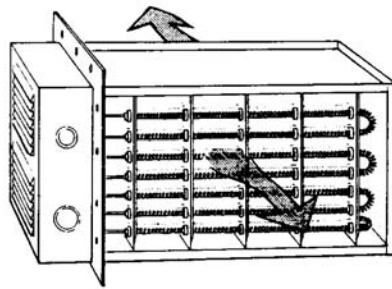
**Table 2**

MAXIMUM OUTLET TEMP. (°F)	1" INSULATION IN TERMINAL BOX	OPTIONAL 4" INSULATION (STANDARD-ON-1200°F HEATER)
	TERMINAL BOX TEMP. (°F)	TERMINAL BOX TEMP. (°F)
250	225	125
400	350	175
600	500	225
750	600	275
1200	N/A	400

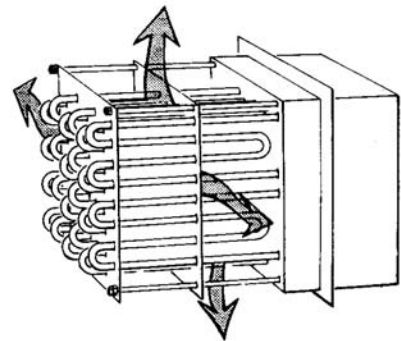
**INSTALLATION DRAWINGS FOR PROCESS AIR HEATERS**



**FIGURE 1**

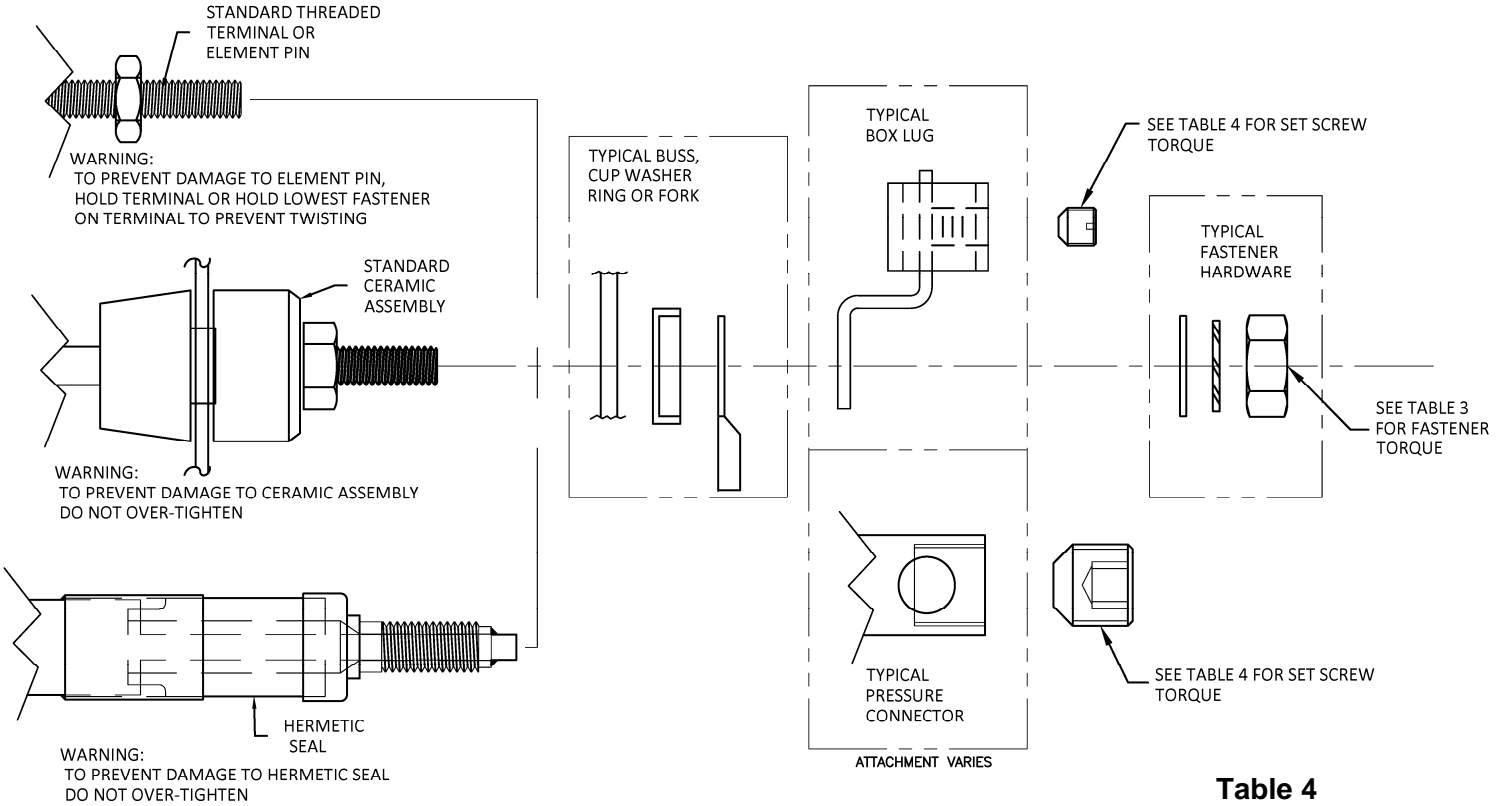


**FIGURE 2**



**FIGURE 3**

# ELECTRICAL CONNECTION TORQUE REQUIRMENTS



**Table 3**

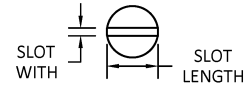
FASTENER TORQUE RECOMMENDATIONS

Application	Thread Size	Torque (in-lbs)
Standard	#10-32	20
Hermetic	1/4-28	30

**Table 4**

GENERAL TORQUE RECOMMENDATIONS (REF. UL STD 486)

Wire Ga (AWG)	HEX INTERNAL SOCKET (ALLEN)	SLOTTED SMALLER THAN 3/64" X 1/4"	SLOTTED LARGER THAN 3/64" X 1/4"
	Torque (in-lbs)	Torque (in-lbs)	Torque (in-lbs)
14-10	60-75	15-20	25-35
8	60-75	20-25	30-40
6-4	90-110	25-35	35-45
3	125-150	25-35	40-50
2	125-150	30-40	40-50
1	125-150	N/A	40-50



**INDEECO**  
 425 Hanley Industrial Court  
 St. Louis, MO 63144  
 Phone: (314) 644-4300 Fax: (314) 644-5332  
 www.indeeco.com

File No. : ENM - 2050 - 01