

Honeywell

Indeco part number 1007044
Honeywell number T678F-1002

T678 THERMOSTATS CONTROL
2-STAGE HEATING OR COOLING SYS-
TEMS, OR ACT AS TOBACCO CURING
CONTROLS.

- T678C models are changeover thermostats.
- T678D,F,G are 2-stage controllers.
- T678E is a tobacco curing control.
- Models with case mount through holes in the back of the case.
- Models without case mount with front mounting bracket.
- Enclosed switches resist the effects of dust and moisture.
- Set point adjusts with knob or screw on front of thermostat.

THERMOSTATS

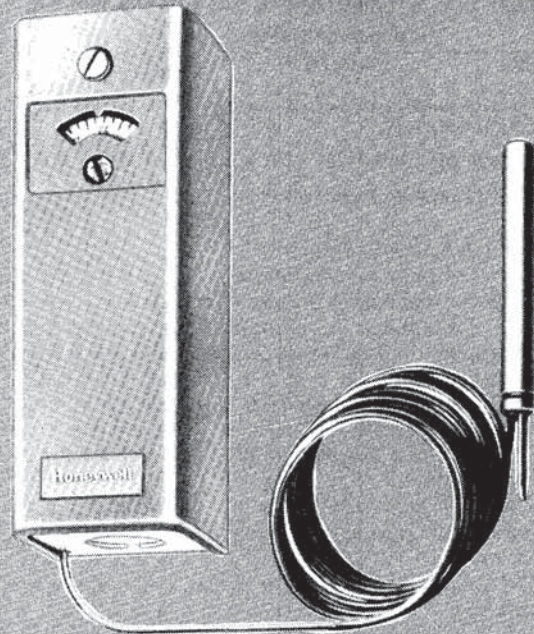

T678C-G

SPECIFICATIONS

For model information see Table 1 and descriptions below.

NOTE: Metric equivalents shown in brackets.

TABLE I—MODELS

MODEL NUMBER	TEMPERATURE SCALE RANGE-MARKED	MAX. TEMP.	DIFFERENTIAL	INTERSTAGE DIFF. (degrees)	ADJUSTMENT MEANS	BULB SIZE, IN in. [mm] WITH 5-1/2 ft [1.68 m] CAPILLARY
T678C	55 to 85 F; 60-70-80 [13 to 29 C; 15.5-21-26.5]	205 F [96 C]	5 F [2.77 C]	—	Screw	3/8 x 3 [9.5 x 76.2]
T678F	55 to 85 F; 60-70-80 [13 to 29 C; 15.5-21-26.5]	130 F [54 C]	2 F [1.11 C]	2-1/2 F [1.4 C]	Screw	5/16 x 11-11/16 [7.9 x 296.9]
	15 to 30 C; 20-25-30	82 C	1.2 C	1.4 C	Screw	7/16 x 3-13/16 [11.1 x 96.8] ^a
T678D	55 to 90 F [13 to 32 C] warmer-cooler	130 F [54 C]	2 F [1.11 C]	2 F ^c [1.1 C]	Knob	5/16 x 11-11/16 [7.9 x 296.9]
T678E	50 to 190 F 10 degree divisions	210 F	b	7 F [3.9 C]	Screw	30 in. bulb; 10 ft element
T678G	15 to 75 F	125 F	3 F [1.7 C]	6.5 F [3.6 C]	Screw	3/8 x 6-1/4 [10 x 159]

^a7 ft [2.1 m] capillary.

^bControl switch differential—2 F [1.11 C]; Hi-limit switch differential—5 F [2.77 C].

^c2 F [1.1 C] deadband between switches.

MODELS (also refer to Table I):

T678C Changeover Thermostat—2 standard spdt switches operate in unison; with case and cover.

T678F Two-stage Thermostat—2 standard spdt switches operate in sequence; with case and cover.

T678D Two-stage Thermostat—2 standard spdt switches operate in sequence; without case.

T678E Tobacco Curing Control—2 spdt switches; without case.

T678G Refrigeration Thermostat—2 standard spdt switches operate in sequence; with case and cover.

TERMINALS: 8/32 binder-head screws and cupwashers.

ELECTRICAL RATINGS (A):

SWITCHES REFER TO MODEL USED	120 Vac		240 Vac	
	FULL LOAD	LOCKED ROTOR	FULL LOAD	LOCKED ROTOR
Light Duty	3.2	19.2	1.6	9.6
Standard	8.0	48.0	5.1	30.6
Control Switch T678E Only	2.6	15.6	1.3	7.8
Hi Limit Switch T678E Only	7.4	44.4	5.1	30.6

T678C,D,F: 1600 VA maximum load.

T678G—0.25 A at 1/4 V to 12 Vdc inductive load.

(continued next page)

ORDERING INFORMATION

WHEN PURCHASING REPLACEMENT AND MODERNIZATION PRODUCTS FROM YOUR TRADELINE WHOLESALE OR YOUR DISTRIBUTOR, REFER TO THE PRICE SHEETS FOR COMPLETE ORDERING NUMBER, OR SPECIFY—

1. Order number.
2. Scale range.
3. Mounting bracket on models without case.
4. Optional specifications, if desired.
5. Accessories, if desired.

IF YOU HAVE ADDITIONAL QUESTIONS, NEED FURTHER INFORMATION, OR WOULD LIKE TO COMMENT ON OUR PRODUCTS OR SERVICES, PLEASE WRITE OR PHONE:

1. YOUR LOCAL HONEYWELL RESIDENTIAL SALES OFFICE (CHECK WHITE PAGES OF YOUR PHONE DIRECTORY).
2. RESIDENTIAL DIVISION CUSTOMER SERVICE
HONEYWELL INC., 1885 DOUGLAS DRIVE NORTH
MINNEAPOLIS, MINNESOTA 55422 (612) 542-7500

(IN CANADA—HONEYWELL LIMITED/HONEYWELL LIMITEE, 750 ELLESMERE ROAD, SCARBOROUGH, ONTARIO M1P 2V9) INTERNATIONAL SALES AND SERVICE OFFICES IN ALL PRINCIPAL CITIES OF THE WORLD.

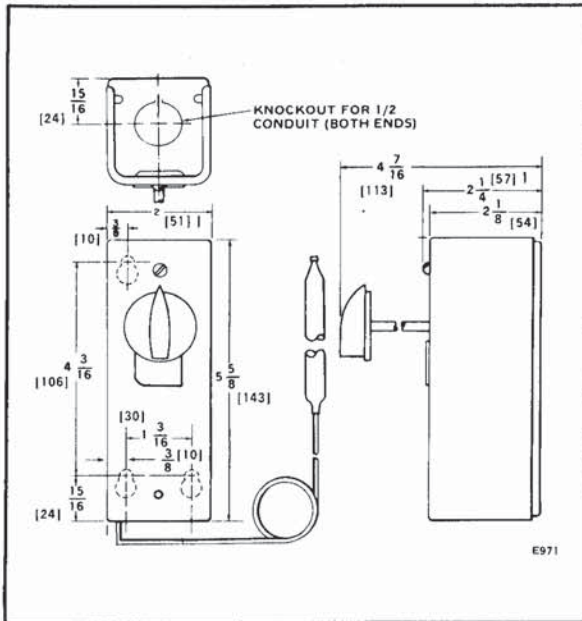

FIG. 1—APPROXIMATE DIMENSIONS IN in. [mm IN BRACKETS] OF T678 (with case). ONLY T678D HAS KNOB.

MOUNTING MEANS:

- T678C,F,G—holes in back of case.
- T678D—front bracket mounting.
- T678E—stud mounting.

DIMENSIONS:

- Case—see Figs. 1 and 2.
- Models without case, including brackets—see Fig. 3.

FINISH: Gray.

UNDERWRITERS LABORATORIES INC.:

- LISTED (T678C,F)—File No. E4436, Guide No. XAPX;
- (T678G)—File No. SA481, Guide No. 361E5.30.
- COMPONENT RECOGNIZED (T678D)—File No. E4436, Guide No. XAPX2.

ACCESSORIES:

1. 105900 Mounting Clamp for mounting element to a pipe; for T678C Changeover Thermostat.
2. Compression fittings.

BULB SIZE	BRASS	MILD STEEL	STAINLESS STEEL
Up to 1/2 in. [12.7 mm] dia.	7617M	7617Y	7617DC

3. Waste nuts: 7617BE for 1/2 in. NPT opening; 7617BF for 3/4 in. NPT opening.
4. Immersion well assemblies:

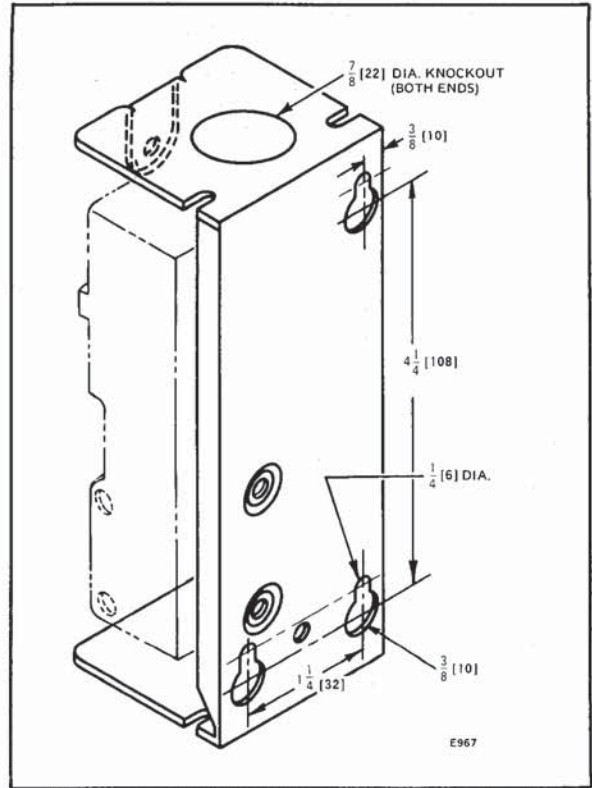

FIG. 2—CASE MOUNTING HOLES, IN in. [mm].

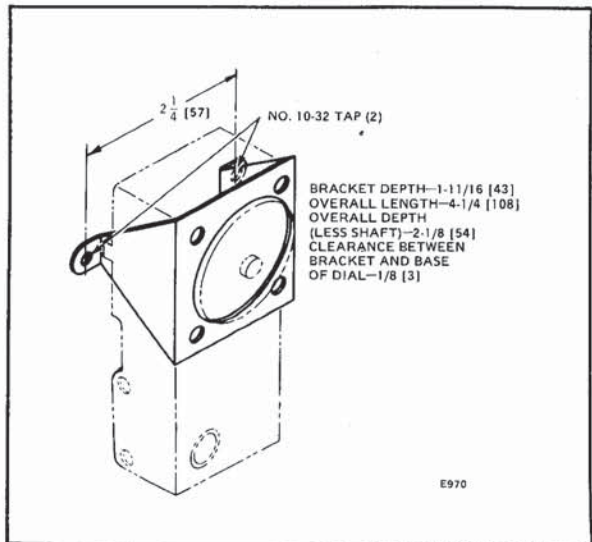

FIG. 3—FRONT MOUNTING BRACKET, IN in. [mm].

BULB SIZE	COPPER		STAINLESS STEEL	
	1/2 in. NPT	3/4 in. NPT	1/2 in. NPT	3/4 in. NPT
3/8 x 3 in. [9.5 x 76.2 mm] (1-1/2 in. [38.1] insulation) (3 in. [76.2 mm] insulation)	121371A 121371L	121371B 121371M	121371E —	121371F —
1/2 x 4 in. [12.7 x 101.6 mm] (1 in. [25.4] insulation) (4-1/4 in. [108 mm] insulation)	112622AA 112626AA	112630AA —	112624AA 112628AA	112632AA —

For additional information on accessory parts, refer to the TRADELINE Catalog.

INSTALLATION

WHEN INSTALLING THIS PRODUCT . . .

1. Read these instructions carefully. Failure to follow them could damage the product or cause a hazardous condition.
2. Check the ratings given in the instructions and on the product to make sure the product is suitable for your application.
3. Installer must be a trained, experienced service technician.
4. After installation is complete, check out product operation as provided in these instructions.

CAUTION

Disconnect power supply before beginning installation to prevent electrical shock and equipment damage.

LOCATION AND MOUNTING

T678 Thermostats mount either vertically or horizontally on a wall or panel. The remote bulb may be located as far from controller as capillary tubing will allow. The bulb should be located where it senses the average temperature of the medium to be controlled.

MOUNTING SENSING ELEMENTS

T678D,F—install bulb in return airflow.

T678C,G—install bulb in water supply where water of average temperature will circulate around bulb. The bulb may be strapped to a water pipe using an accessory clamp (see Fig. 4).

T678E—install bulb where it will sense average temperature of the tobacco curing area and with 10 ft [3 m] of capillary in the controlled space.

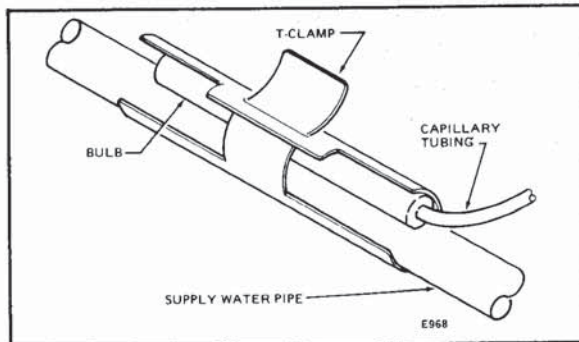

FIG. 4—BULB STRAPPED TO SUPPLY WATER PIPE WITH 105900 T-CLAMP.

MOUNTING CONTROLLER

MODELS WITH CASE

1. Loosen the captive mounting screw above the dial on the face of the thermostat and remove the cover. (On models with an adjustment knob, remove the knob first by loosening the setscrew.)
2. Fasten the case to the wall or panel through mounting holes in the back of the case with furnished screws. (See Figs. 1 and 2.)
3. Run the tubing through the most convenient of the 4 corner notches in the case. Do not bend tubing so sharply that flow is restricted. Leave excess tubing coiled near the thermostat.
4. Make wiring connections according to the instructions in WIRING.
5. Replace the cover. Do not pinch the tubing. Tighten the cover mounting screw.

MODELS WITHOUT CASE

Front mounting brackets are available. See Fig. 3 for mounting information and dimensions.

WIRING

Disconnect power supply before connecting wiring to prevent electrical shock and equipment damage.

All wiring must comply with local codes and ordinances.

When wiring, refer to the wiring diagrams furnished with system equipment and to Figs. 5-9.

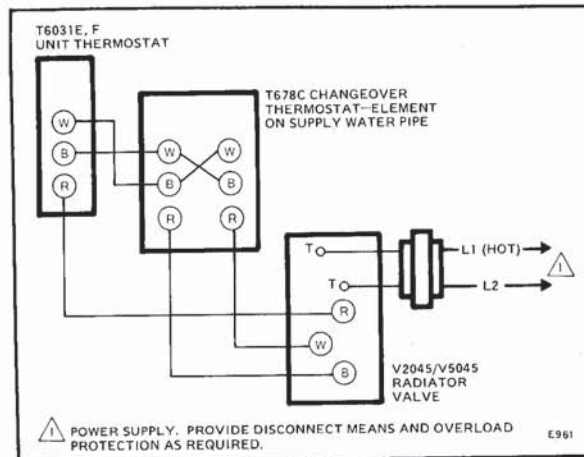

FIG. 5—TYPICAL HOOKUP FOR T6031E,F WITH T678C CHANGEOVER THERMOSTAT CONTROLLING V2045/V5045 VALVE ON BOTH HEATING AND COOLING CYCLES.

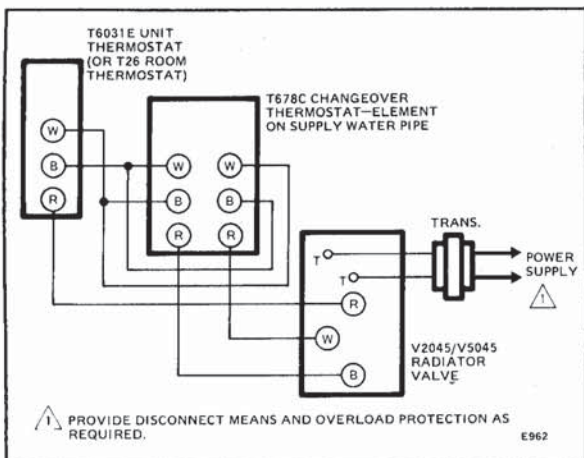

FIG. 6—TYPICAL HOOKUP FOR T678C CHANGEOVER THERMOSTAT USED WITH T6031E UNIT THERMOSTAT AND V2045/V5045 VALVE FOR HEATING AND COOLING CONTROL.

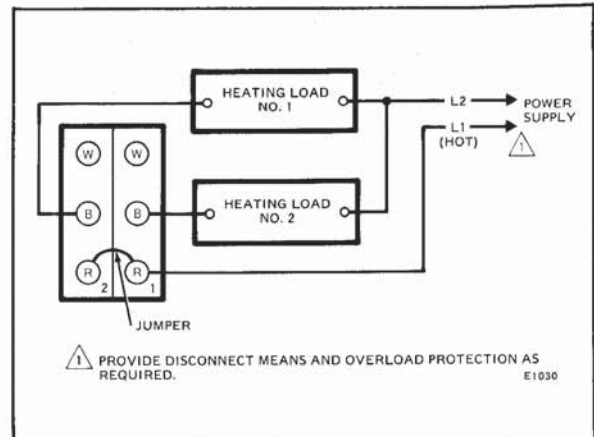

FIG. 8—TYPICAL HOOKUP FOR 2-STAGE HEATING.

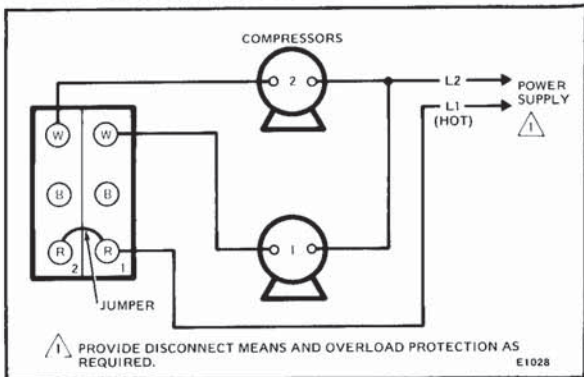

FIG. 7—TYPICAL HOOKUP FOR CONTROLLING 2 COMPRESSORS.

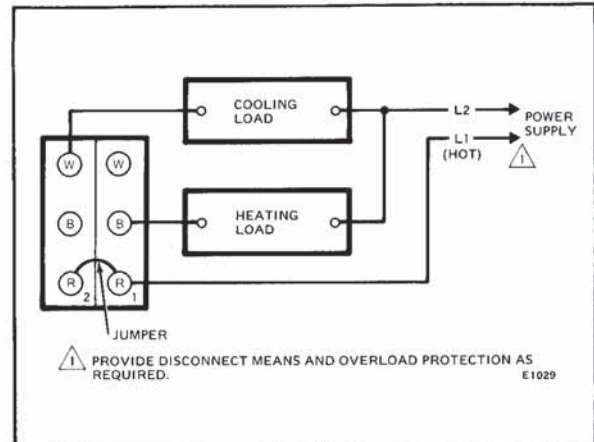

FIG. 9—TYPICAL HOOKUP FOR 1-STAGE HEATING AND 1-STAGE COOLING.

OPERATION AND CHECKOUT

After the T678 is installed and wired into the system, check controller action by raising the temperature set point about 10 F [5.6 C] above room temperature. Heating equipment should stop or cooling equipment should begin operation, depending upon the application. Lower set point below room temperature. Heating equipment should begin operation or cooling equipment should stop, depending upon application.

T678D,F,G Thermostats have sequenced switching action as shown in Fig. 10. Allow the system to operate and make sure that controlled equipment operates as desired.

These controllers are accurately calibrated at the factory and no field calibration should be needed. Thermostats do not require lubrication.

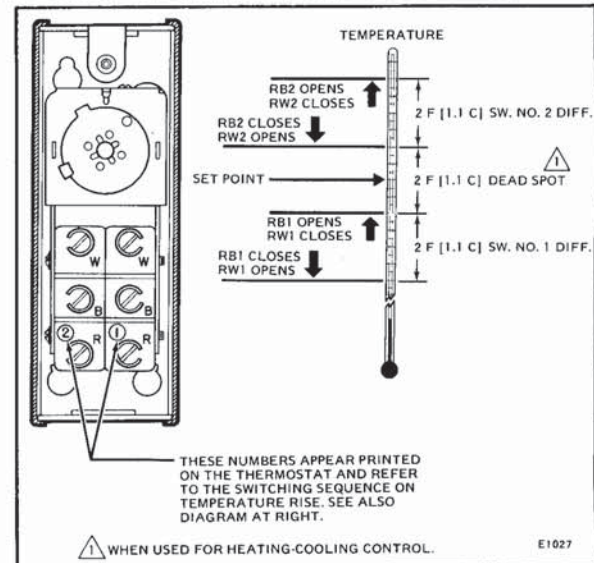

FIG. 10—SWITCH TERMINAL ARRANGEMENT AND SWITCHING SEQUENCE OF T678D,F.

If questions arise regarding installation, operation, or checkout of this equipment, contact your distributor or local Honeywell representative.

By using this Honeywell literature, you agree that Honeywell will have no liability for any damages arising out of your use or modification to, the literature. You will defend and indemnify Honeywell, its affiliates and subsidiaries, from and against any liability, cost, or damages, including attorneys' fees, arising out of, or resulting from, any modification to the literature by you.

HONEYWELL MINNEAPOLIS, MN 55408. International Sales Offices in all principal cities of the world. Manufacturing in Australia, Canada, Finland, France, Germany, Japan, Mexico, Netherlands, Spain, Taiwan, United Kingdom, U.S.A.

PRINTED IN U.S.A.