



Johnson Controls, Inc.
Penn Division

1302 E. Monroe St.
Goshen, IN 46526

Thermistor Room Temperature Sensor

APPLICATION

This solid state thermistor room sensor detects temperature changes in a room or similar space. Use with a Penn Series R93 electronic controller to position an ACTROL™ sequencer or a Series M80J motor actuator. Series T91 sensors may be used directly with Series M40E and M40F motor actuators.

INSTALLATION

Locating

Locate the sensor where it will be exposed to normal free air circulation and where it senses the average temperature of the space being controlled.

Do not mount where it may be affected by heat or cold from water pipes, windows, doors, lamps, sunlight, or other heat or cold sources.

The sensors are supplied with factory installed vertical faceplates as standard. If horizontal mounting is desired, faceplates are available for on-the-job installation to convert the vertical models to horizontal.

Mounting

To mount the sensor select the proper mounting location and proceed as follows:

1. Install a 2 x 3 outlet box.
2. Remove mounting plate from back of sensor. Pull wires from outlet box and insert through the mounting plate.
3. Secure the mounting plate to the outlet box with the two screws provided.

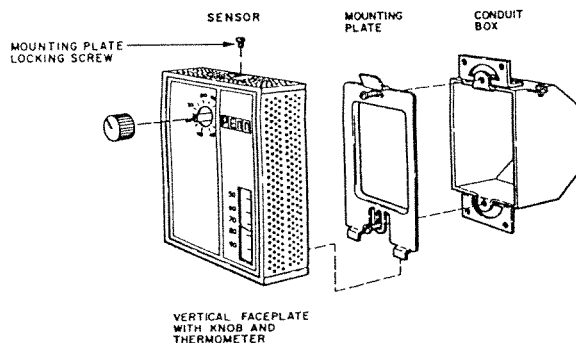

Fig. 2 — Line drawing illustrating method of mounting a vertical sensor to outlet box.

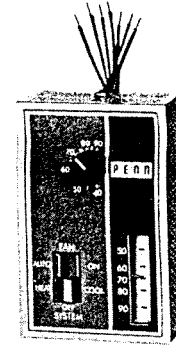

Fig. 1 — Type T91BCB sensor.

4. Make wiring connections to color coded leads. See "Wiring" section for wiring information.
5. Hook the two slots in back of sensor over the formed prongs on mounting plate and swing into place against mounting plate. Tighten mounting plate locking screw, see Figs. 2 and 3.

Wiring

CAUTION: Disconnect power supply to motor actuator or sequencer before wiring connections are made to prevent possible electrical shock or damage to equipment.

All wiring should conform to the National Electrical Code and local regulations.

Refer to job wiring diagrams for proper hook up. If not available, see wiring diagrams in this instruction sheet.

Make all wiring connections and recheck them before applying power. Improper wiring may cause permanent damage.

If the sensor wires are run in the same conduit with any other wires in conformance with the N.E.C. or through areas where heavy electrical currents exist, use metal shielded cable. The shield must be grounded only at the signal center or controller. Use No. 22 gauge wire, Belden 8761, for the sensor runs up to 250 feet. From 250 feet to 500 feet, use No. 18 gauge wire, Belden 8760.

Optional Faceplate Installation

1. Mount the sensor as specified.

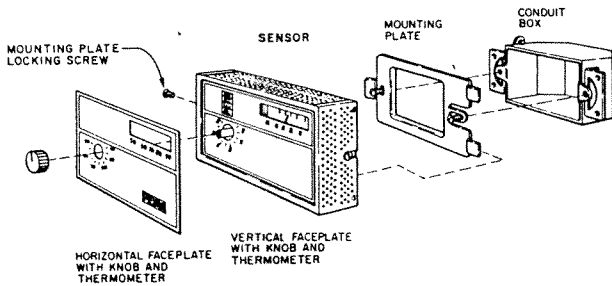

Fig. 3 — Line drawing illustrating method of mounting a vertical thermostat to a horizontal outlet box and installing a horizontal faceplate.

2. Note the temperature setting indicated by knob index pointer. Loosen screw in knob and remove knob.

NOTE: Do not turn adjusting shaft when knob is removed. If the range shaft is turned while knob is loose or removed, the factory calibration will be lost. See "Calibration Adjustment" when replacing knob.

3. Peel off backing strip from selected faceplate.
4. Position plate over factory installed plate with one long edge and two corners aligned straight and even with installed plate.
5. Retain position and firmly press selected faceplate onto cover.
6. Replace knob with index pointer at the setting noted in Step 2, when used.



ADJUSTMENTS

Calibration Adjustment

If range shaft is turned while knob is removed, factory calibration is lost. To restore knob to correct position, proceed as follows:

1. Turn range shaft counterclockwise  to rotation limit.
2. Replace knob with index pointer aligned with 40° F (5° C) on the faceplate dial.
3. Tighten knob set screw to secure knob in place on the shaft.
4. Turn knob so index pointer is aligned with desired sensor setting. Allow time for room temperature to balance and compare sensor set point with actual room temperature. If recalibration is required, refer to the following instructions.

In some applications the sensor dial setting will not appear to agree with the actual room temperature. To recalibrate proceed as follows:

1. Remove sensor from wall box. Note the access hole for the adjustable calibration potentiometer in back of case.
2. To cause the T91 to control at a higher actual temperature for a given dial pointer setting, use a narrow blade screwdriver and turn this potentiometer clockwise  toward "INC" stamped on case. One mark on case represents a change of approximately 2° F (1.1° C).
3. To cause the T91 to control at a lower actual temperature for a given dial pointer setting, turn this potentiometer counterclockwise  toward "DEC."

Make set point changes as follows:

1. Remote set point models — install a Type Y45BA remote set point potentiometer and turn potentiometer adjusting knob to desired temperature.
2. Concealed adjustment models — remove cover and turn adjusting knob to set point desired.
3. External knob adjustment models — turn adjusting knob to set point desired.
4. If required, the thermometer can be recalibrated by turning the hex-head screw inside cover.

CHECKOUT PROCEDURE

Before leaving installation, a complete operating cycle should be observed to see that all components are functioning properly.

Rotate adjusting knob to one extreme. The controlled device should cycle also to that extreme. Next, rotate adjusting knob to opposite extreme. The controlled device should cycle to its opposite extreme.

REPAIRS AND REPLACEMENT

Field repairs must not be made. Replacement sensors may be obtained from the nearest Penn Commercial Wholesaler. When ordering a replacement sensor, specify Product Number and Serial Number shown on the sensor.

WIRING DIAGRAMS

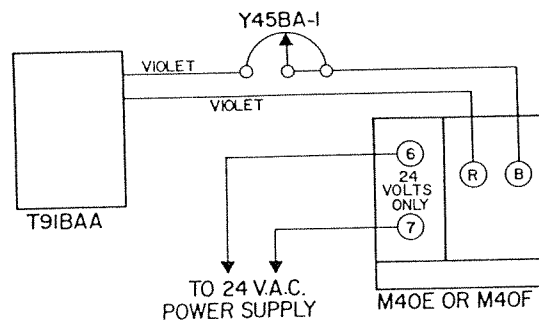

Fig. 4 — Wiring diagram for Type T91BAA and Series M40E or M40F motor actuator with Type Y45BA-1 remote set point adjuster.

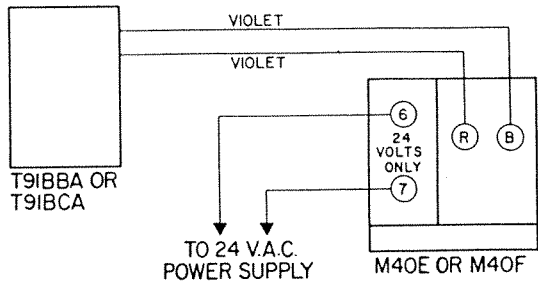

Fig. 5 — Wiring diagram for Type T91BBA or T91BCA and Series M40E or M40F motor actuator.

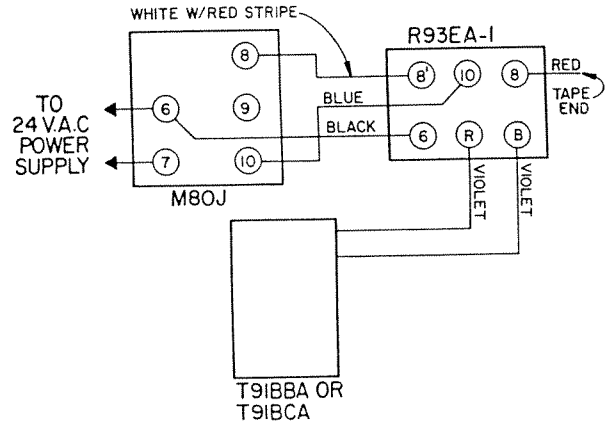

Fig. 6 — Wiring diagram for Type T91BBA or T91BCA and Product No. R93EA-1 controller wired for reverse output. If direct output is desired, connect motor terminal 8 to controller terminal 8 (red lead).

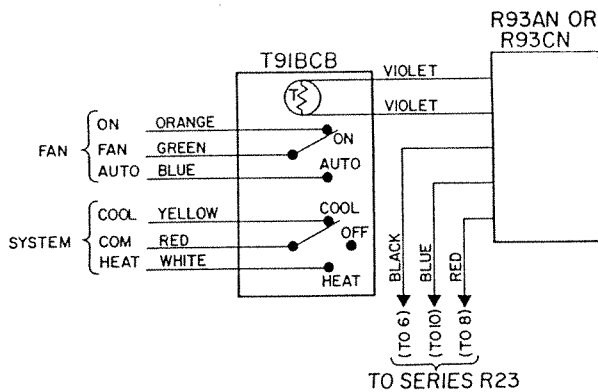

Fig. 7 — Wiring diagram for Type T91BCB with integral fan and system switches and Series R93 controller.

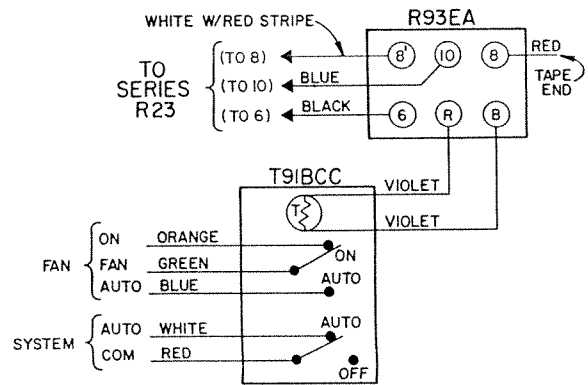

Fig. 8 — Wiring diagram for Type T91BCC with integral fan and system switches and Series R93 controller.

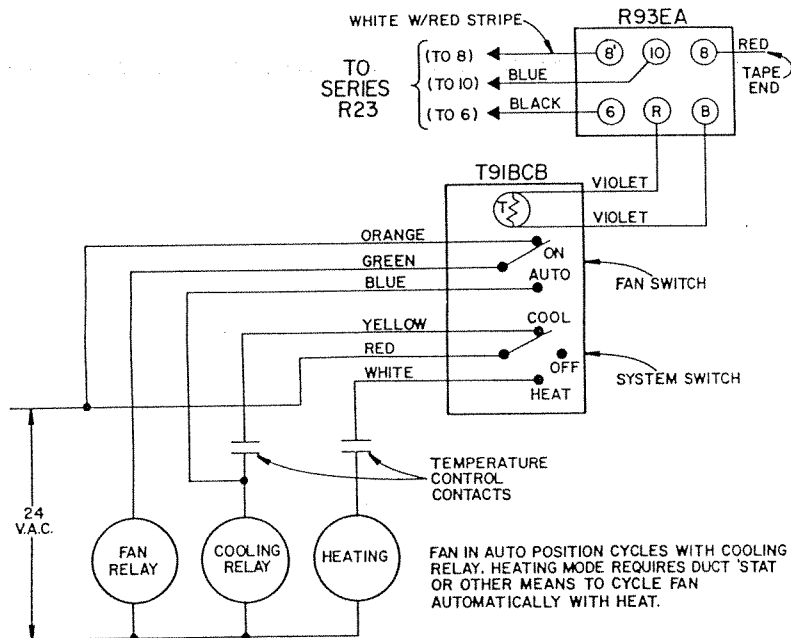

Fig. 9 — Typical hook-up for Type T91BCB controlling both heating and cooling.