



www.indeeco.com

208 Series 4-Stage Controls

Operation

The 208 Series step control provides linear sequencing of 2, 3 or 4 contactor stages for multi-branch loads. Stage 1 is the first stage to be turned ON and the last stage to be turned OFF. 16 selectable time delays determine when stages are added or removed (see table). The total number of stages ON is proportional to the 4-20mA or 0-10VDC input signal (see table). If the input is open or shorted, all stages are OFF.

Features of this control include dip switch programming, status leds and diagnostics. The test mode will cycle the selected number of stages with a 1 second delay. Load wiring, contactors and stage operation can be verified.

A vernier control is available, which results in more precise control than is possible with a standard step control. A separate power controller provides proportional control (0-100% load), in between the switching on and off of step control stages.

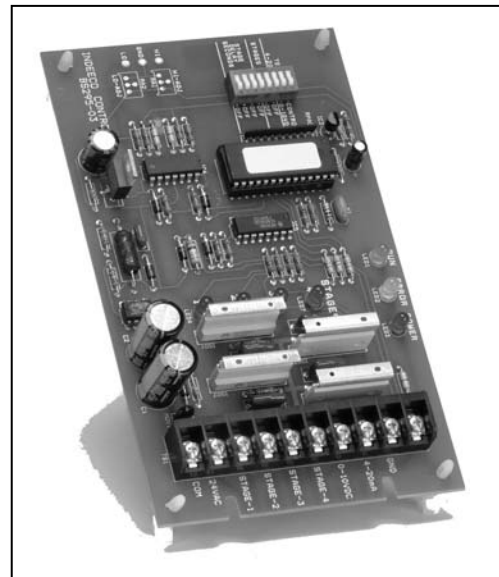

Specifications

- Storage Temp: 0° to 186°F
- Operating Temp: 0°F to 167°F
- UL Recognized: File E52105 Guide XAPX2
- Operation: Class II low voltage circuit.
- Control Voltage: 24VAC +/- 10%, 6VA max.
- Frequency: 47 to 63 Hz, sinewave only
- Stage Outputs: Pilot-duty triacs, 17VA max.
- Vernier Output: 12VDC pulse, 0.5VA max.
- Inputs: 4-20mA (250Ω), 0-10VDC (10KΩ)
- Wire Range: 14-22 AWG, copper only
- Adjustable Time Delay: 1-75 seconds

Catalog and Part Numbers:

208-1942

Fixed 4-20mA and 0-10VDC inputs

208-1943

Adjustable mA and VDC inputs

Switch 3 4	0-10VDC Input, No Vernier			
	Stage 1	Stage 2	Stage 3	Stage 4
Off Off	5.0VDC	9.5VDC	X	X
On Off	3.3VDC	6.7VDC	9.5VDC	X
On On	2.5VDC	5.0VDC	7.5VDC	9.5VDC

Switch 3 4	0-10VDC Input, With Vernier			
	Stage 1	Stage 2	Stage 3	Stage 4
Off Off	3.3VDC	6.7VDC	X	X
On Off	2.5VDC	5.0VDC	7.5VDC	X
On On	2.0VDC	4.0VDC	6.0VDC	8.0VDC

Switch 3 4	4-20mA Input, No Vernier			
	Stage 1	Stage 2	Stage 3	Stage 4
Off Off	12.0mA	19.5mA	X	X
On Off	9.4mA	14.8mA	19.5mA	X
On On	8.0mA	12.0mA	16.0mA	19.5mA

Switch 3 4	4-20mA Input, With Vernier			
	Stage 1	Stage 2	Stage 3	Stage 4
Off Off	9.4mA	14.8mA	X	X
On Off	8.0mA	12.0mA	16.0mA	X
On On	7.2mA	10.4mA	13.6mA	16.8mA

208-1902 Settings
(2000 - 2001)

208-1942 Settings
(2002 - present)

Delay Settings (seconds):

Sec	Dipswitch			
	40	20	10	5
1	Off	Off	Off	Off
5	Off	Off	Off	On
10	Off	Off	On	Off
15	Off	Off	On	On
20	Off	On	Off	Off
40	On	Off	Off	Off
60	On	On	Off	Off
75	On	On	On	On

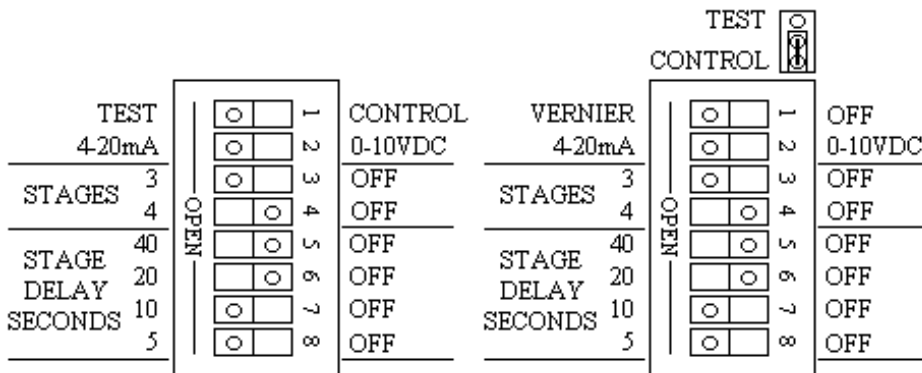

Note: The control must be powered down before changing the dip switches.

Wiring Diagram

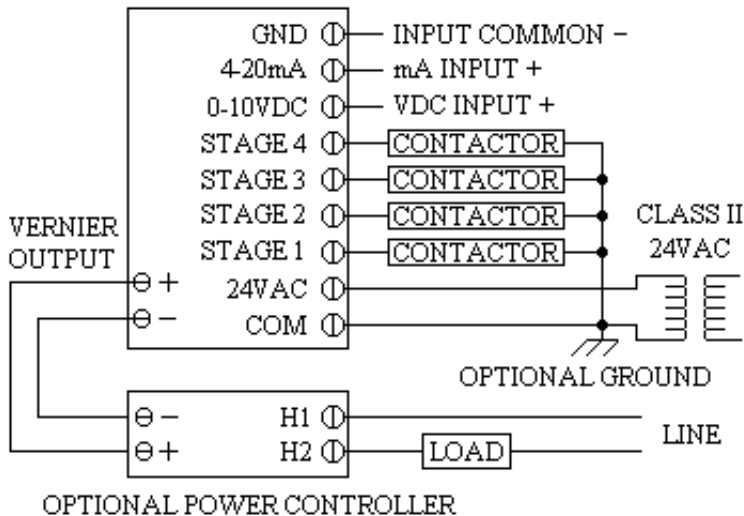

Physical Dimensions

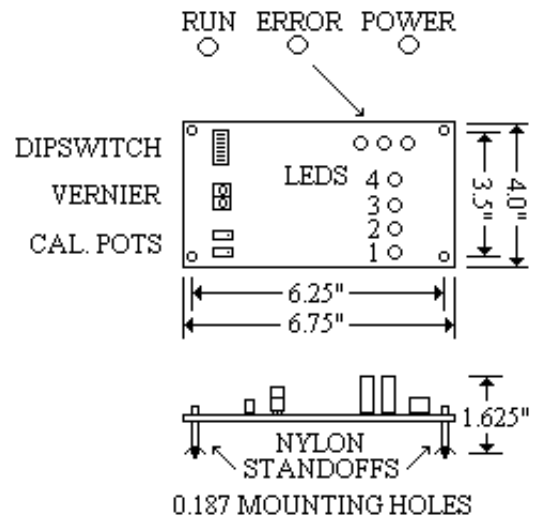

Note: GND and COM are electrically connected on the circuit board.

Status LEDs

Power (Red)	ON = 24VAC power applied	OFF = no 24VAC power
Run (Green)	OFF = input calling for all stages off. ON = input calling for all stages on. Flashing = input signal is within the selected input range.	
Error (Yellow)	OFF = normal operation in CONTROL mode. ON = input dip switch setting does not match input signal or TEST mode selected.	
1, 2, 3, 4 (Red)	ON when the corresponding stage and pilot-duty triac are energized, otherwise OFF.	

INDECO CONTROLS

425 Hanley Industrial Ct
St Louis, MO 63144

phone: 314-644-4300

fax: 314-644-5332

www.indeco.com

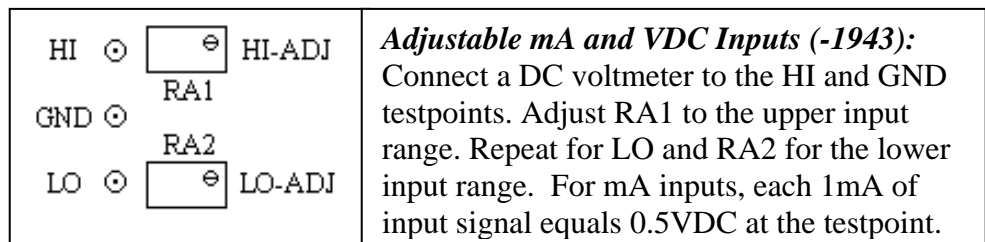

Adjustable mA and VDC Inputs (-1943):

Connect a DC voltmeter to the HI and GND testpoints. Adjust RA1 to the upper input range. Repeat for LO and RA2 for the lower input range. For mA inputs, each 1mA of input signal equals 0.5VDC at the testpoint.