

# INVIZATHERM®



# &

# INVIZATHERM THIN®

## ELECTRIC INFRARED COMFORT HEATERS



- 100% electric IR flat panel emitter, operates in long wave length.
- Listed for mounted or suspended indoor and outdoor protected environments. Ideal for comfort heating and snow/ice control.
- Single and Three Phase designs. All standard US voltages available.
- All models available in Stainless Steel or high temp powder coated black or white.
- ZERO MAINTENANCE: no moving parts, , no fans, and no dangerous bulbs to clean or replace.
- No orange glow: this heater does not emit any visible light.
- 95% energy efficient
- MADE IN THE USA

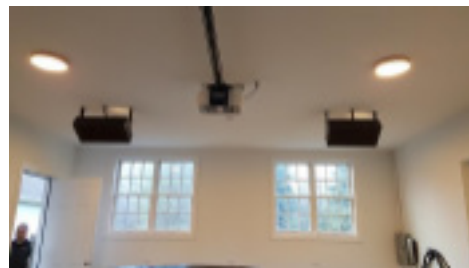

INDEECO, LLC

425 Hanley Industrial Court – St. Louis, MO 63144 – (800) 243-8162

Fax: (314) 644-4300 – [www.indeeco.com](http://www.indeeco.com)

# Table of Contents

Features	1
Heater Models and Dimensions Heat	3
Distribution and Selecting Quantity	4
Invizatherm Mounting Applications	5
Invizatherm Specifications	7
Invizatherm Wiring Requirements	7
Invizatherm Wiring Diagrams	9
Invizatherm Thin Mounting Applications	16
Invizatherm Thin Specifications	19
Invizatherm Thin Wiring Requirements	19
Invizatherm Thin Wiring	20

# INVIZATHERM SERIES



12" Model		Single Phase		
Model	BTUs*	Watts	120V	240V
STS-U12-0871B	2972	871	7.3	-
STS-U12-1081B	3707	1081	9.0	-
STS-U12-1111B	3789	1111	9.3	-
STS-U12-1681B	5927	1681	14.2	-
STS-U12-1436J	5573	1436	6.8	-

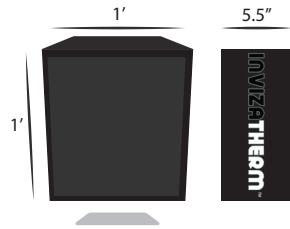

Shipping Weight 10 lbs.

24" Model		Single Phase				Three Phase
Model	BTUs*	Watts	120V	208V	240V	240V
STS-U24-1015V	3559	783 /1015	-	3.8	4.3	-
STS-U24-1316B	4490	1316	11.0	-	-	-
STS-U24-1297V	4426	974 /1297	-	4.7	5.4	-
STS-U24-1659B	5662	1659	13.8	-	-	-
STS-U24-1701V	5804	1278 /1701	-	6.1	7.1	-
STS-U24-2192B	7479	2192	18.3	-	-	-
STS-U24-2001V	6827	1503 /2001	-	7.2	8.3	-
STS-U24-2222B	7578	2222	18.5	-	-	-
STS-U24-2428V	8285	1824 /2428	-	8.8	10.2	-
STS-U24-3363B	11614	3363	28.4	-	-	-
STS-U24-3239V	11052	2433 /3239	-	11.7	13.5	-
STS-U24-1992P	6811	1992	-	-	-	4.8
STS-U24-2442P	8351	2442	-	-	-	5.9
STS-U24-3041P	10400	3041	-	-	-	7.3

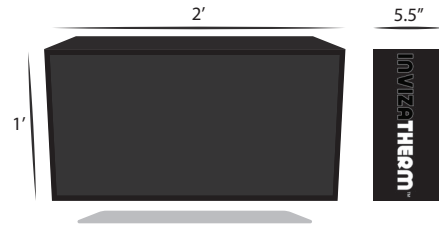

Shipping Weight 20 lbs.

48" Model			Single Phase					Three Phase	
Model	BTUs*	Watts	120V	208V	240V	277V	480V	240V	480V
STS-U48-2030T	7118	2030	-	-	-	-	4.3	-	-
STS-U48-2030V	7118	1567 /2030	-	7.5	8.7	-	-	-	-
STS-U48-2594T	8851	2594	-	-	-	-	5.4	-	-
STS-U48-2594V	8851	1948 /2594	-	9.4	10.8	-	-	-	-
STS-U48-3402T	11608	3402	-	-	-	-	7.1	-	-
STS-U48-3402V	11608	2555 /3402	-	12.3	14.2	-	-	-	-
STS-U48-4002T	13654	4002	-	-	-	-	8.3	-	-
STS-U48-4002V	13654	3006 /4002	-	14.5	16.7	-	-	-	-
STS-U48-3964N	13526	3964	-	-	-	14.3	-	-	-
STS-U48-4856T	16570	4856	-	-	-	-	10.1	-	-
STS-U48-4856V	16570	3647 /4856	-	17.5	20.2	-	-	-	-
STS-U48-4776N	16296	4776	-	-	-	17.2	-	-	-
STS-U48-6478T	22104	6478	-	-	-	-	13.5	-	-
STS-U48-6478V	22104	4866 /6478	-	23.4	27.0	-	-	-	-
STS-U48-6056N	20516	6056	-	-	-	21.7	-	-	-
STS-U48-3971P	13582	3971	-	-	-	-	-	9.6	-
STS-U48-3928U	13803	3928	-	-	-	-	-	-	4.9
STS-U48-4794P	16396	4797	-	-	-	-	-	11.6	-
STS-U48-4838U	16545	4838	-	-	-	-	-	-	5.8
STS-U48-5954P	20933	5954	-	-	-	-	-	14.8	-
STS-U48-6060U	20729	6060	-	-	-	-	-	-	7.3



Shipping Weight 38 lbs.

# INVIZATHERM THIN SERIES

18" Model		Single Phase	
Model	BTUs*	Watts	120V
STT-U18-1091B	3723	1091	9.1
STTU18-1330B	4712	1330	11.5
STT-U18-1767B	6053	1767	14.8
STT-U18-2161B	7373	2161	18.1

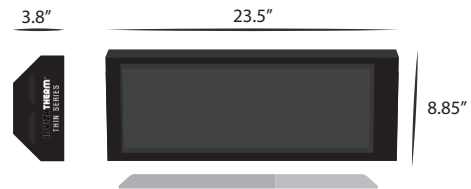

Shipping Weight 16 lbs.

36" Model		Single Phase		
Model	BTUs*	Watts	240V	208V
STT-U36-2180V	7438	1635 /2180	9.1	6.8
STT-U36-2660V	9421	2071 /2660	11.5	8.6
STT-U36-3104V	10591	2328 /3104	12.9	9.7
STT-U36-3534V	12106	2661 /3534	14.8	11.1
STT-U36-4322V	14747	3242 /4322	18.1	15.6

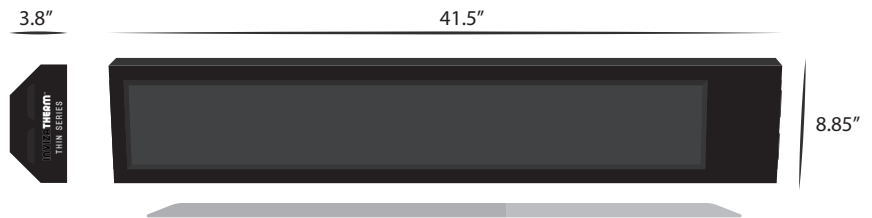

Shipping Weight 21 lbs.

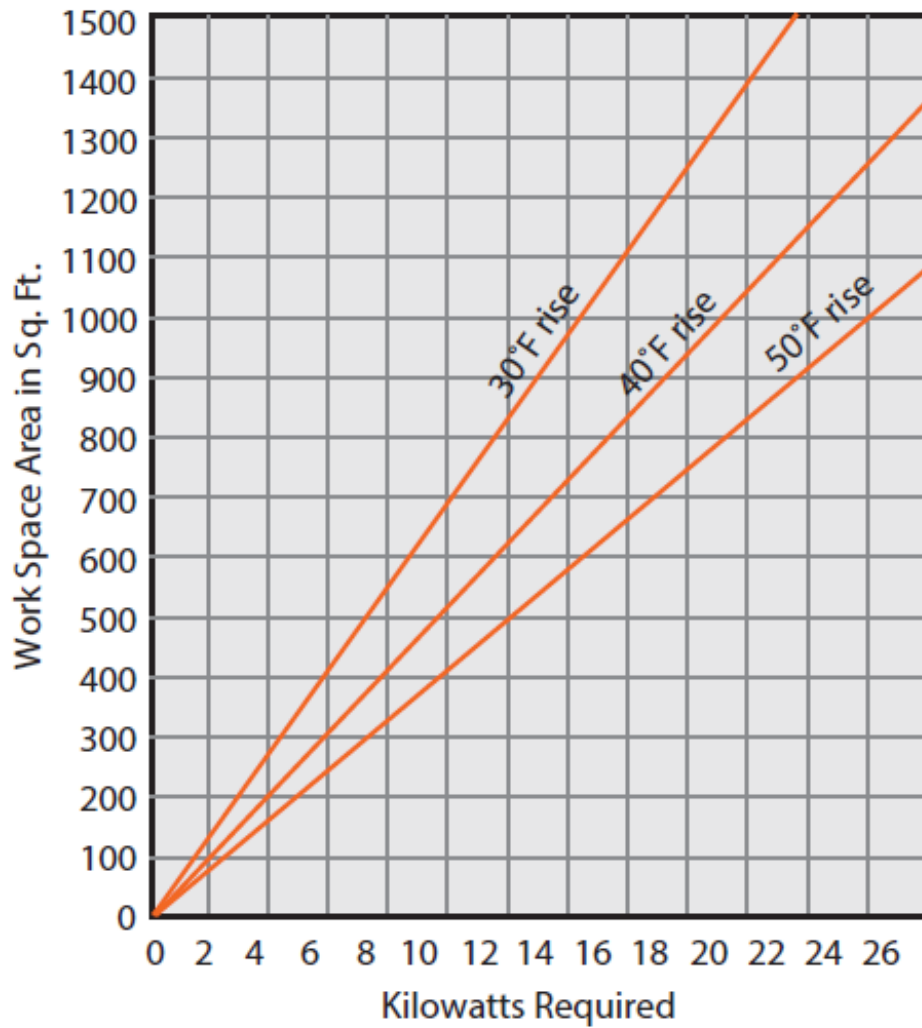

LENGTH B				
HEIGHT A	Model #1 12" Length	Model #2 24" Length	Model #3 48" Length	WIDTH C
6 ft.	7' 10"	8' 10"	10' 10"	7' 10"
8 ft.	10' 2"	11' 2"	13' 2"	10' 2"
10 ft.	12' 6"	13' 6"	15' 6"	12' 6"
12 ft.	14' 10"	15' 10"	17' 10"	14' 10"
14 ft.	17' 2"	20' 2"	22' 2"	17' 2"

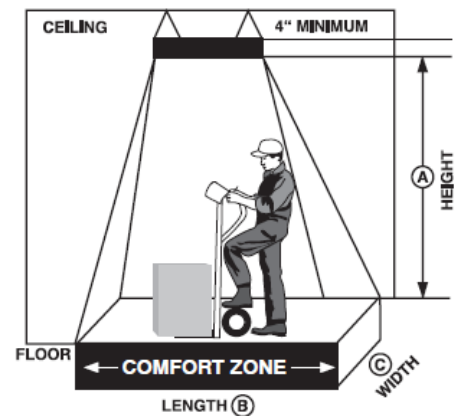

# INVIZATHERM METHODS OF INSTALLATION:



Do not install the heater closer than:

## INDOOR

- 4 inches to a horizontal surface
- 12 inches to a vertical surface
- 36 inches to another heater
- 6 feet from the floor

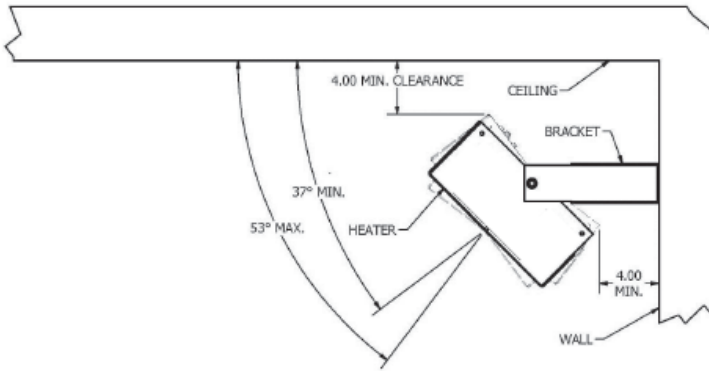

Fig. 1 – WALL MOUNTING

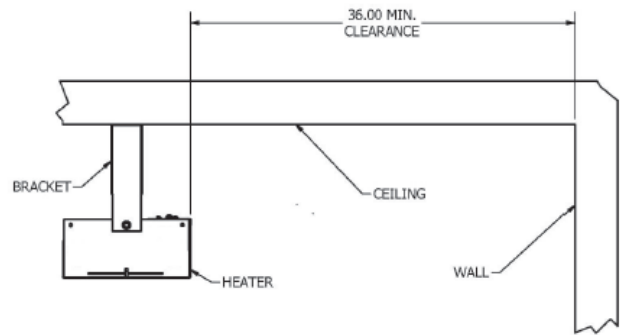

Fig. 2 – CEILING MOUNTING VERTICAL

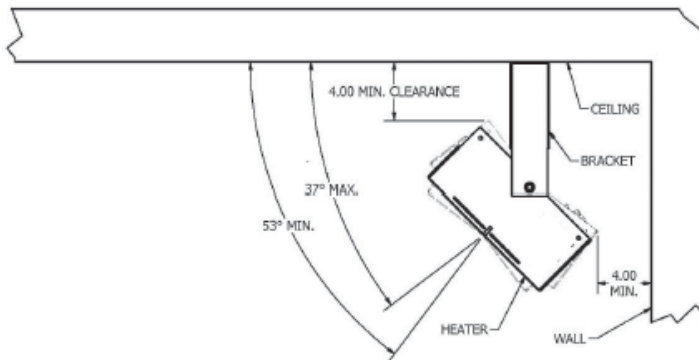

Fig. 3 – CEILING MOUNTING ANGLED AWAY FROM VERTICAL SURFACE

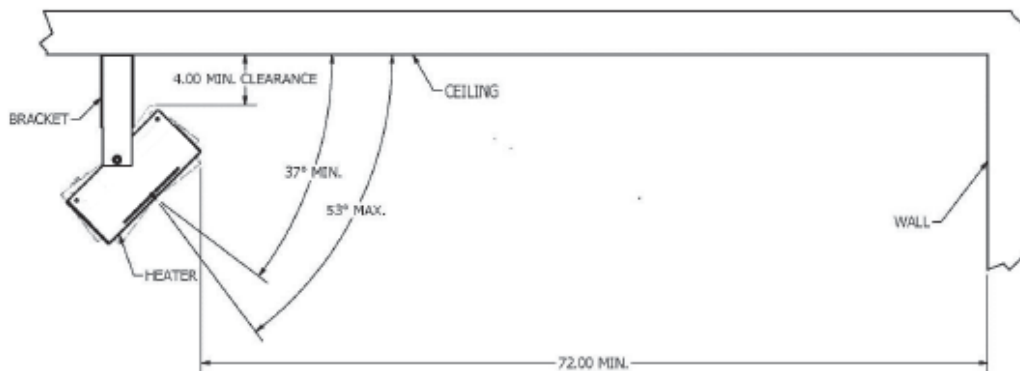

Fig. 4 – CEILING MOUNTING ANGLED TOWARDS VERTICAL SURFACE

# PROTECTED AREA

A *Protected Area* is defined as “Located in an area that is partially protected from the effects of weathering.” Typical *protected areas* would be the underside of a pavilion with a roof, garage port, and the like.



Adhere to all mounting guidelines above. Additionally: no less than 18" from ledge.

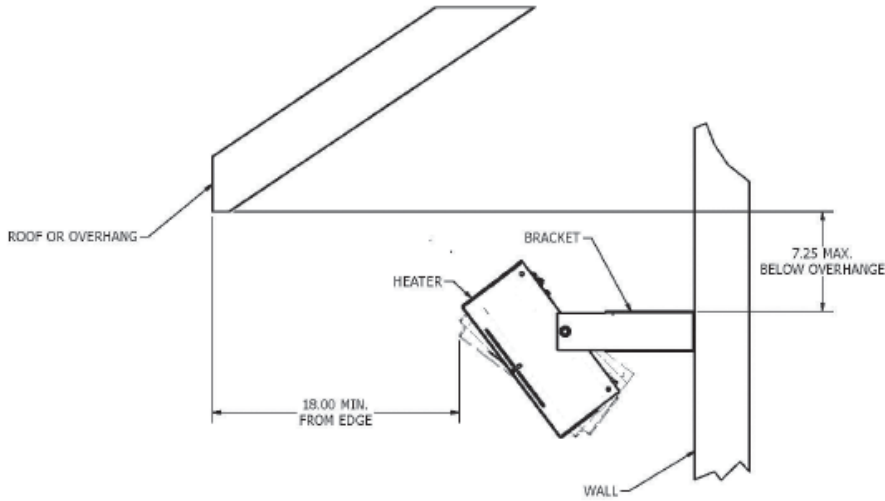

**Fig. 5 – PROTECTED AREA WALL MOUNTING**

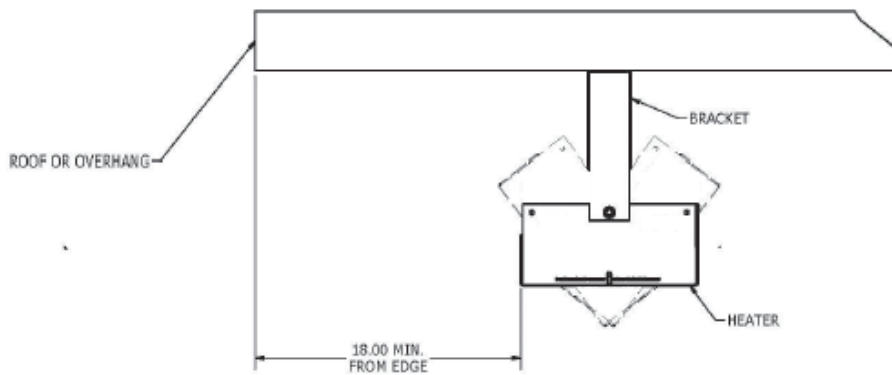

**Fig. 6 – PROTECTED AREA CEILING MOUNTING**

# Invizatherm

## Infrared Heater Specifications



The electric infrared heater shall be Invizatherm as manufactured by Indeco, St. Louis, MO. The construction and design shall permit it to be ceiling or wall mounted, with the use of the mounting brackets supplied, or chain hung according to supplied instructions. Heaters shall include the features listed below.

**HEATING ASSEMBLY:** The heating assembly shall be UL listed under standard 2021 and shall consist of single stranded, non-coiled Ni-Chrome wire embedded in vitrified ceramic fiber and backed with high density, low biopersistent Fiberfrax insulation. The emitting surface is covered with a black-coated high temperature fiberglass cloth.

**WIRING:** For connection to the power supply, Invizatherm heaters will be prewired with leads housed in a 24 inch flexible metal conduit and connector for j-box mounting.

**CONSTRUCTION:** The heaters are formed and welded together out of 16 ga. and 20 ga. CRS or stainless steel. If CRS, the heater must be powder coated with a high temp black or white finish.



For supply connections use the wire size (or larger) as directed by the chart below. All wires must be suitable for at least 75°C (167°F).

SUPPLY CONNECTIONS				
MODEL NUMBER	120 VOLT AWG. WIRE SIZE	208/240 VOLT AWG. WIRE SIZE	277 VOLT AWG. WIRE SIZE	480 VOLT AWG. WIRE SIZE
STS-U24-1992P STS-U24-2442P STS-U24-3041P STS-U48-3971P	-	14	-	-
STS-U48-4794P STS-U48-5954P	-	12	-	-
STS-U48-3928U STS-U48-4838U STS-U48-6060U	-	-	-	14



## SUPPLY CONNECTIONS

MODEL NUMBER	120 VOLT AWG. WIRE SIZE	208/240 VOLT AWG. WIRE SIZE	277 VOLT AWG. WIRE SIZE	480 VOLT AWG. WIRE SIZE
STS-U12-0871B STS-U12-1081B	14	-	-	-
STS-U12-1111B STS-U12-1681B	12	-	-	-
STS-U12-1436J	-	14	-	-
STS-U24-1015V STS-U24-1316B	14	-	-	-
STS-U24-1659B	12	-	-	-
STS-U24-2192B STS-U24-2222B	10	-	-	-
STS-U24-3363B	8	-	-	-
STS-U24-1297V STS-U24-1701V STS-U24-2001V STS-U24-2428V	-	14	-	-
STS-U24-3239V	-	12	-	-
STS-U48-2030V STS-U48-2594V	-	14	-	-
STS-U48-3402V	-	12	-	-
STS-U48-4002V STS-U48-4856V	-	10	-	-
STS-U48-6478V	-	8	-	-
STS-U48-2030T STS-U48-2594T		14	-	14
STS-U48-3402T		12	-	14
STS-U48-4002T STS-U48-4856T		10	-	14
STS-U48-6478T		8	-	12
STS-U48-3964N			12	-
STS-U48-4776N STS-U48-6056N	-	-	10	-

# FIG. 2 - 12" x 12" SECTIONS 120 / 208 / 240 VOLT - SINGLE PHASE

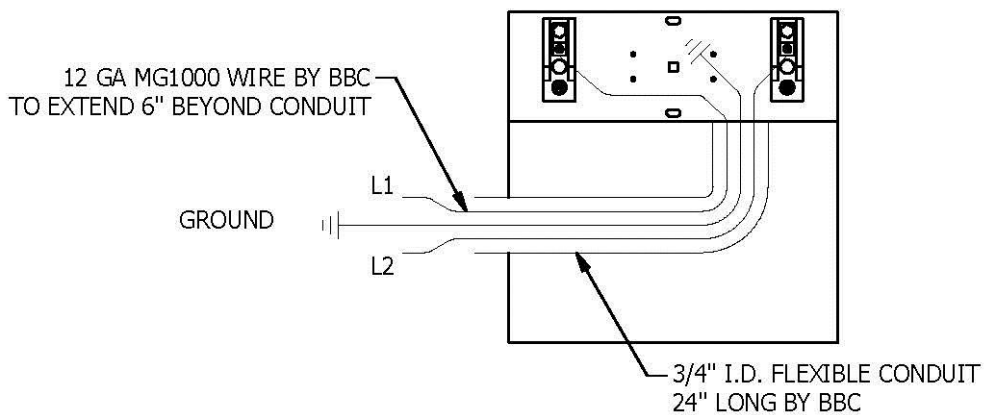
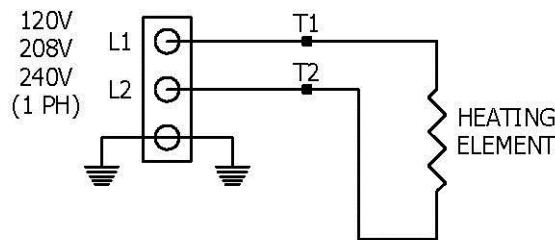
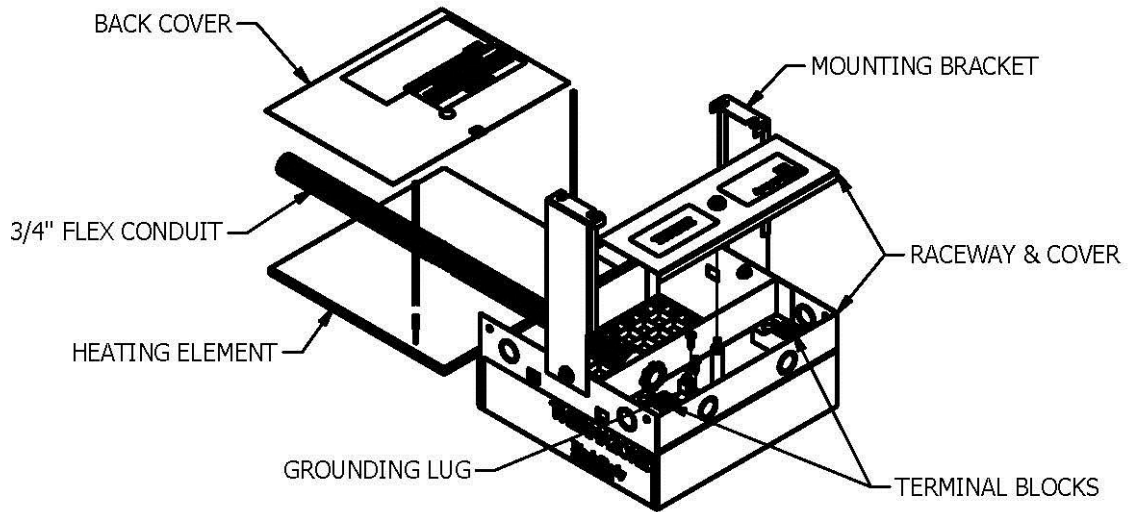
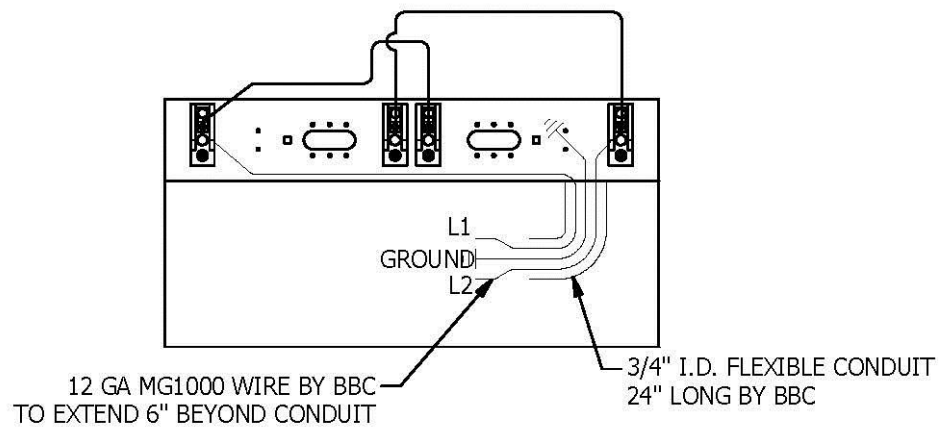
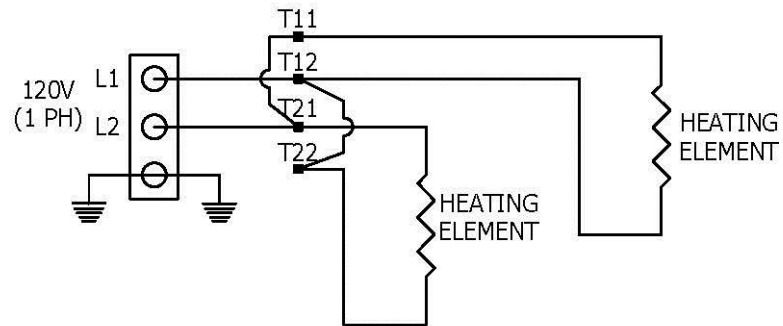
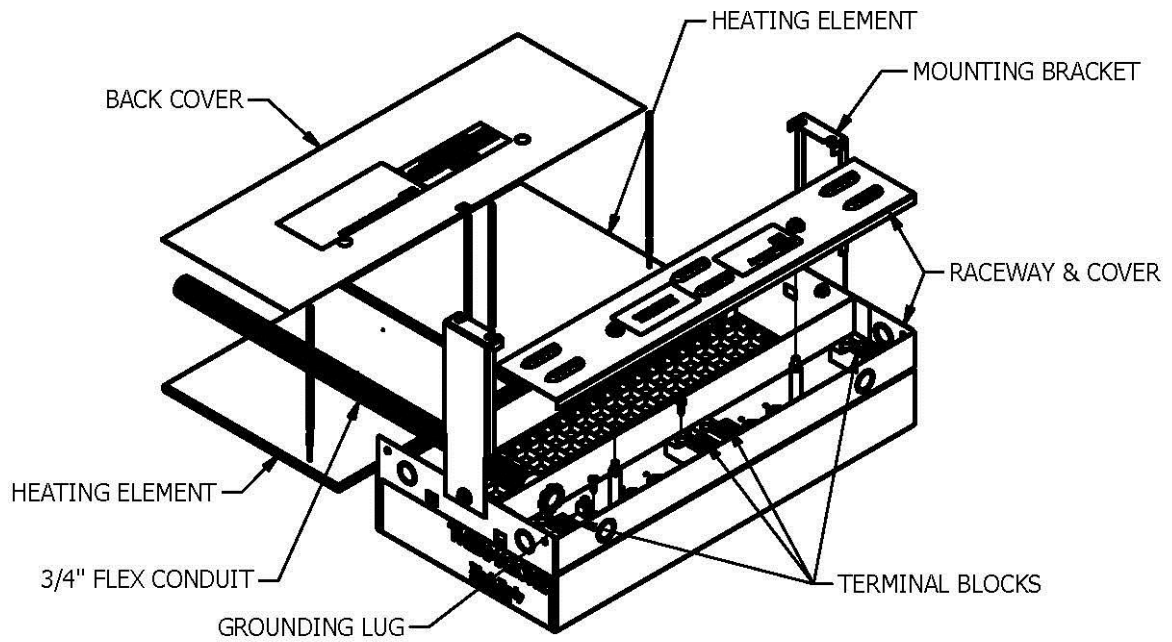

FIG. 3 - 24" x 12" SECTIONS (DUAL ELEMENT)  
120 VOLT - SINGLE PHASE



**FIG. 4 - 24" x 12" SECTIONS (SINGLE ELEMENT)  
120 / 208 / 240 VOLT - SINGLE PHASE**

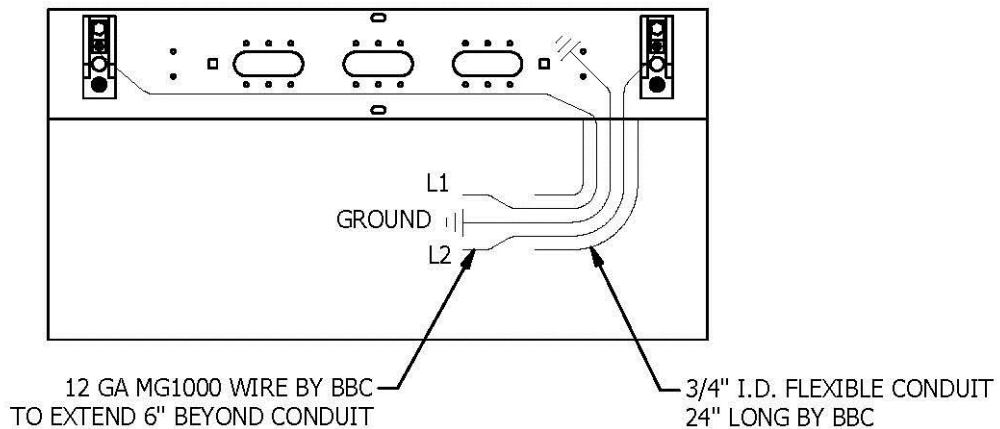
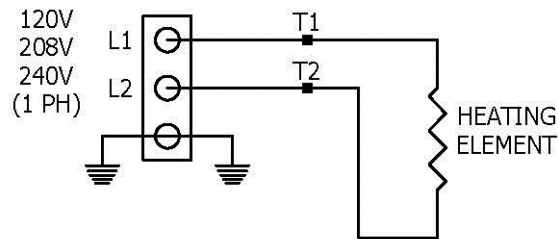
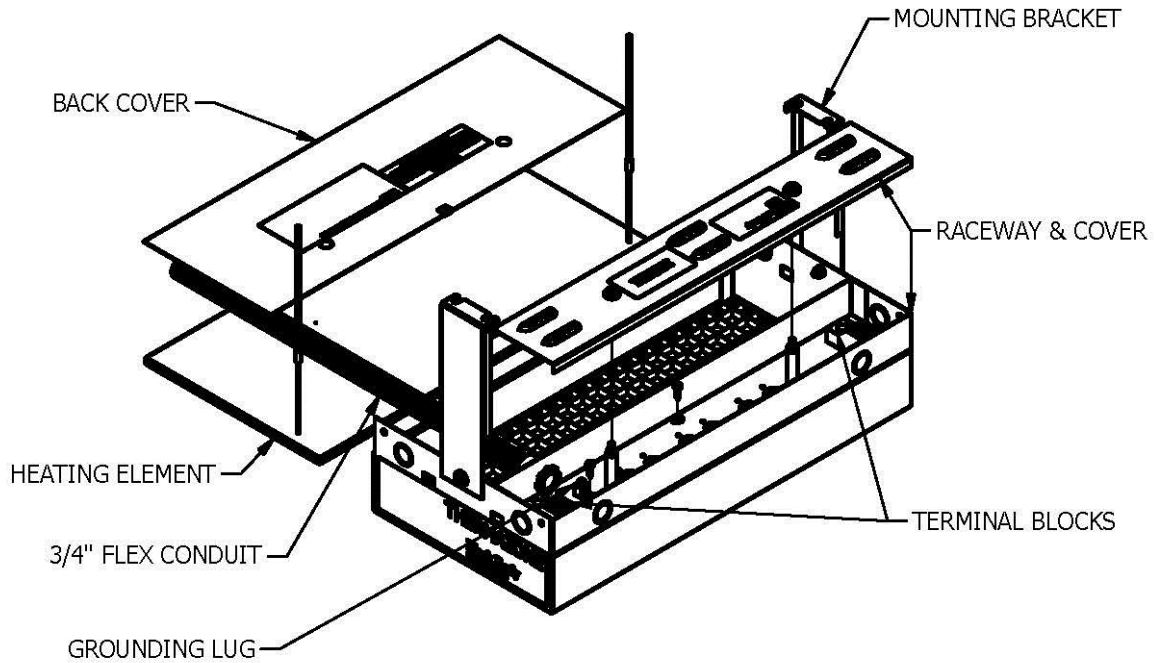
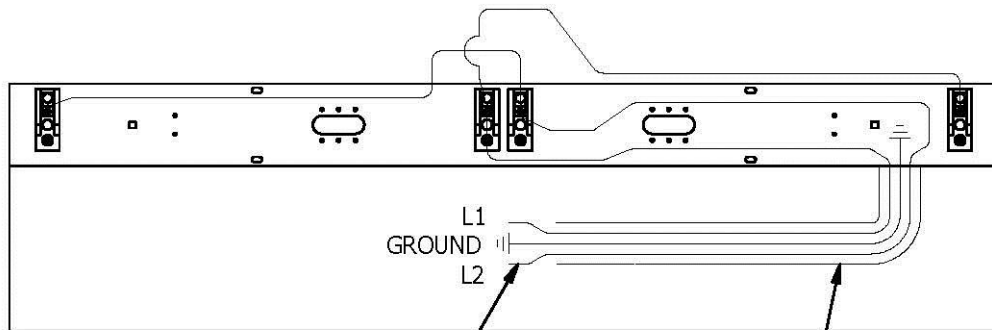
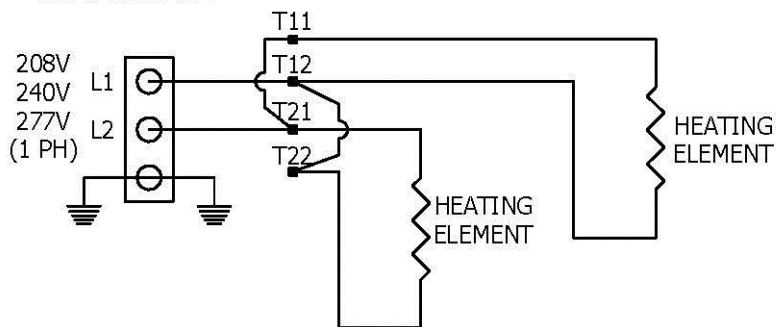
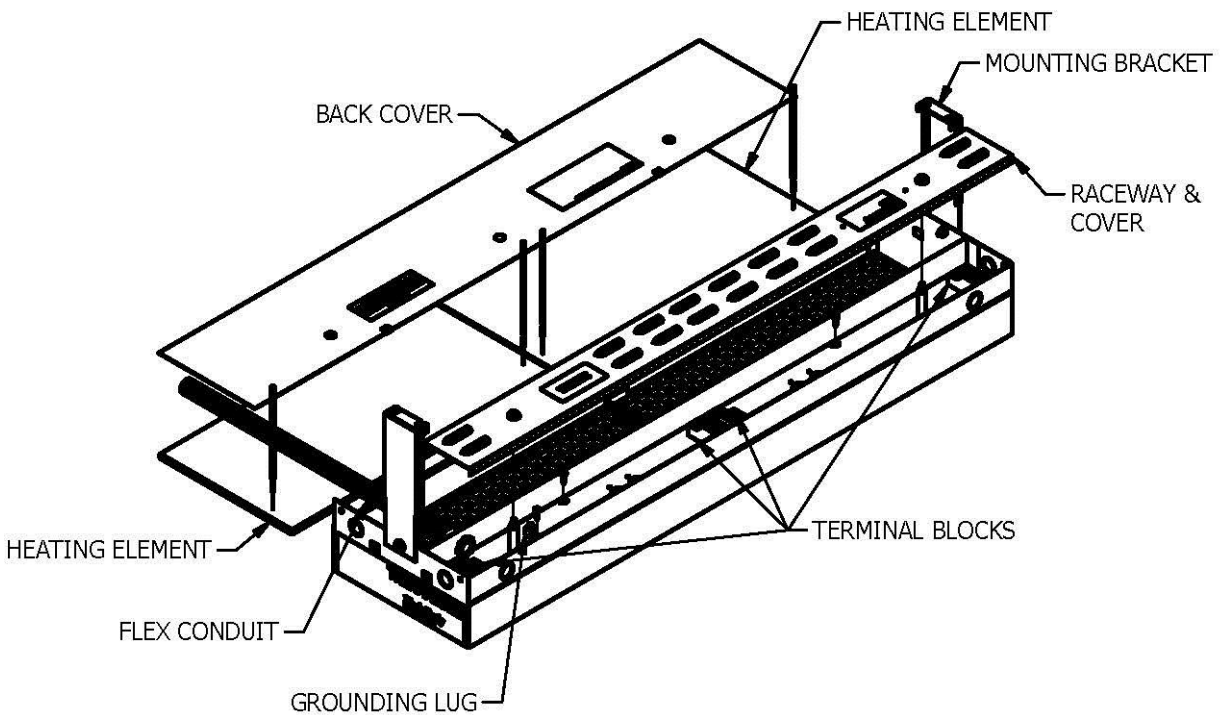

FIG. 5 - 48" x 12" SECTIONS  
 208 / 240 / 277 VOLT - SINGLE PHASE



12 GA MG1000 WIRE BY BBC  
 TO EXTEND 6" BEYOND CONDUIT

3/4" I.D. FLEXIBLE CONDUIT  
 24" LONG BY BBC

FIG. 6 - 48" x 12" SECTIONS  
 277 / DV (480 VOLT WIRING) - SINGLE PHASE

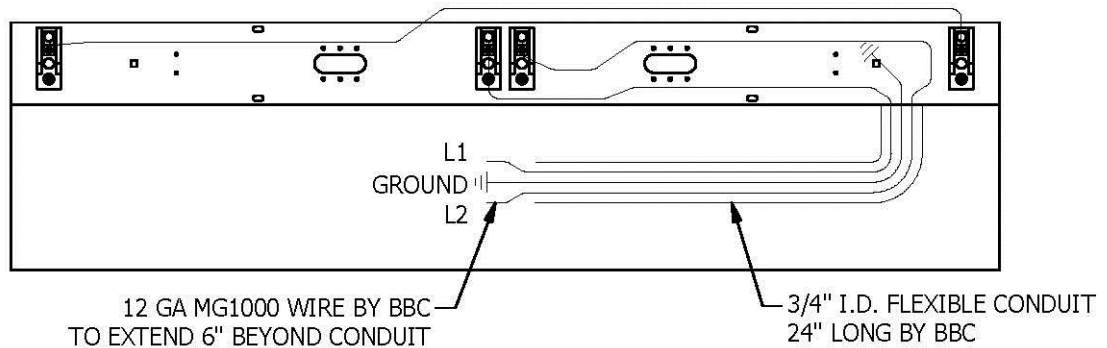
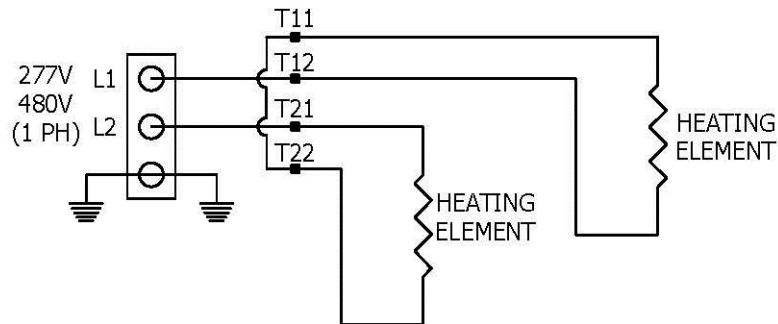
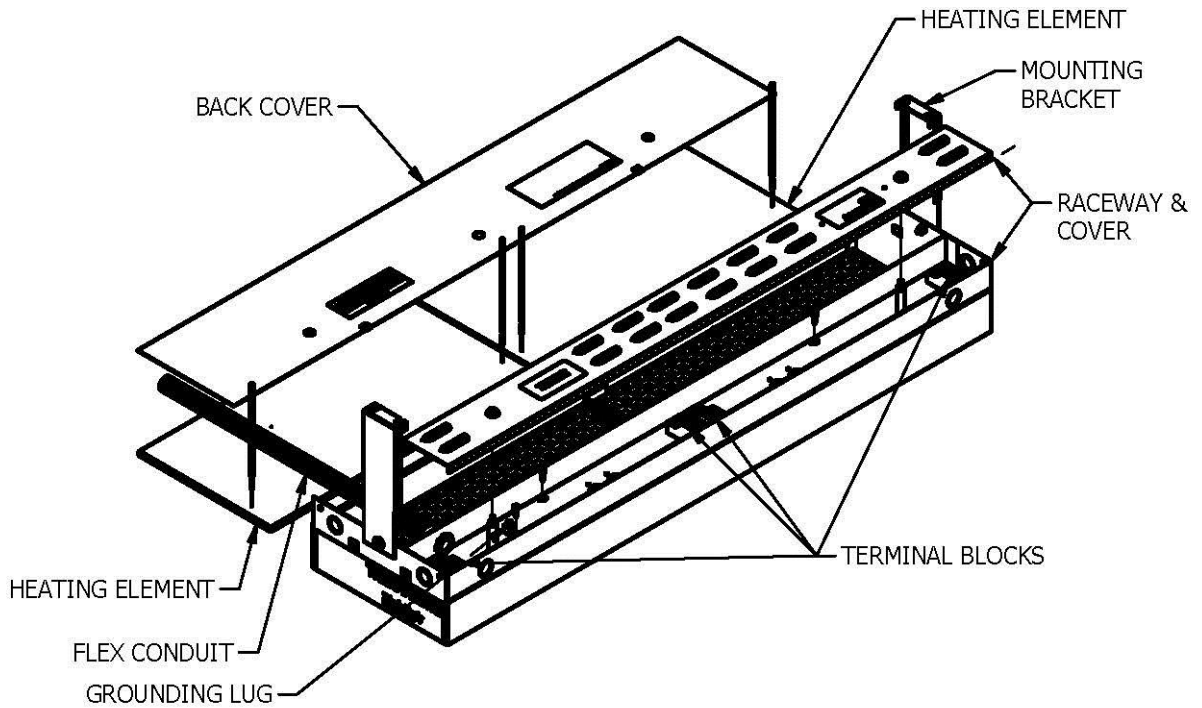

# FIG. 7 - 24" x 12" SECTIONS 240 VOLTS - THREE PHASE

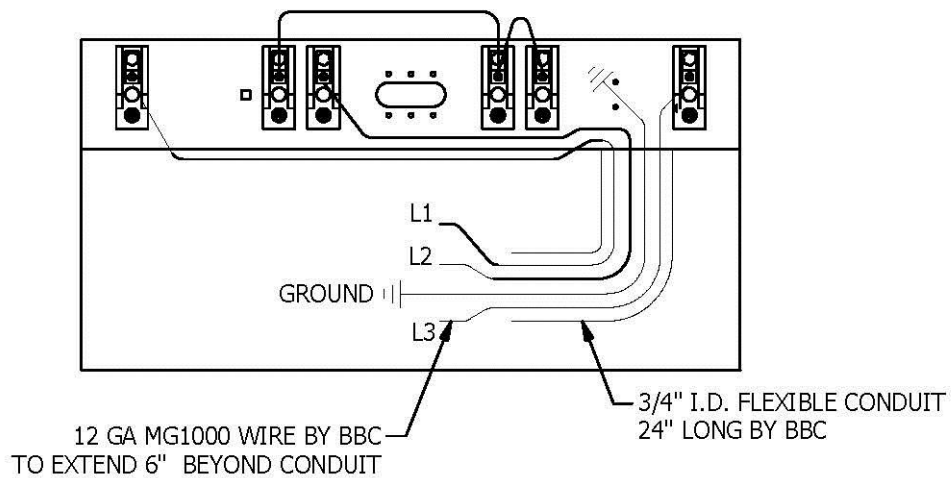
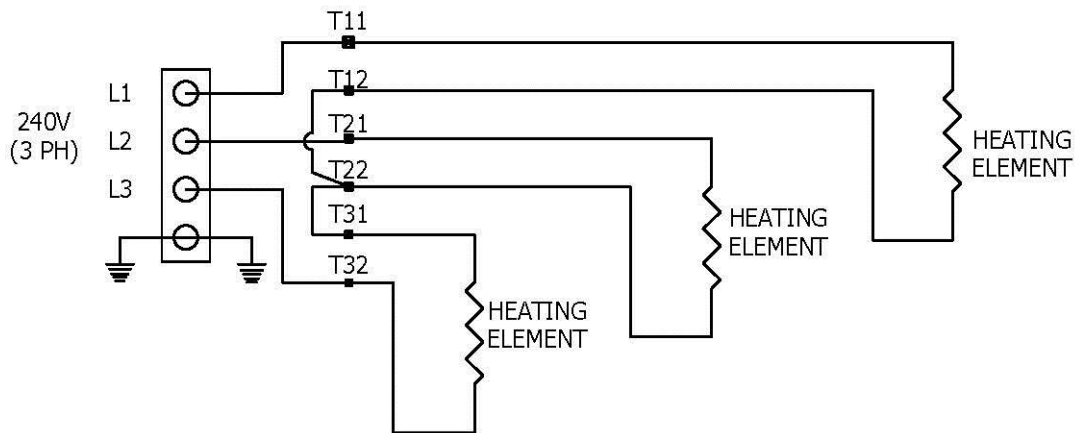
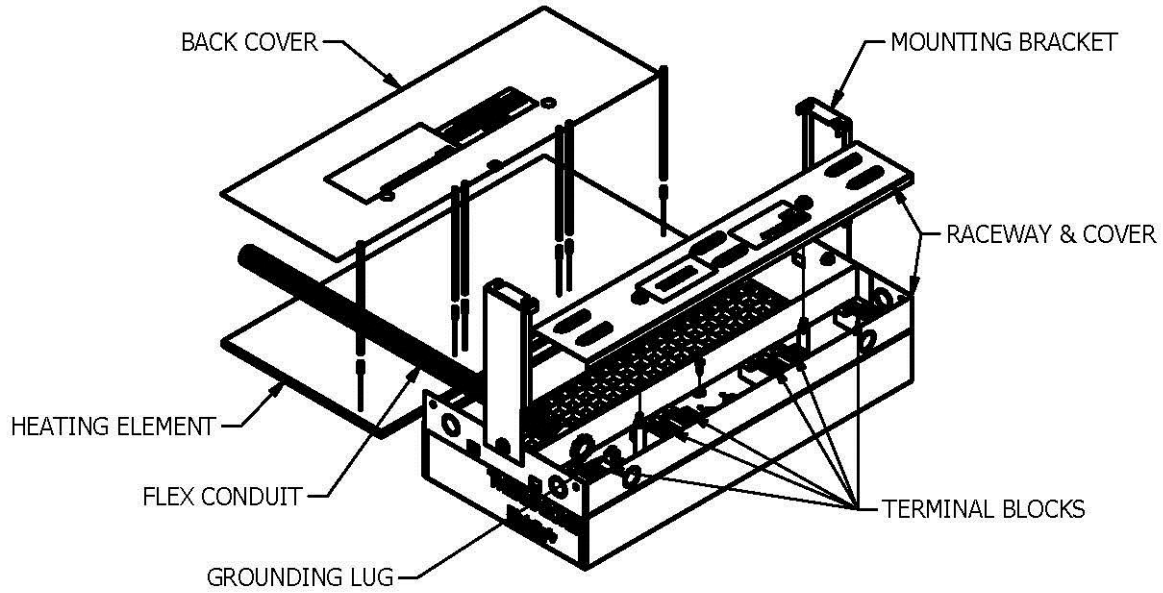

# FIG. 8 - 48" x 12" SECTIONS 240 / 480 VOLTS - THREE PHASE

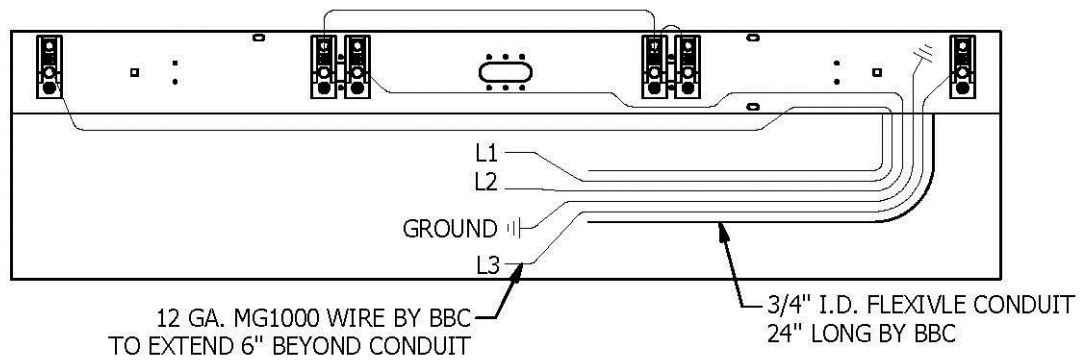
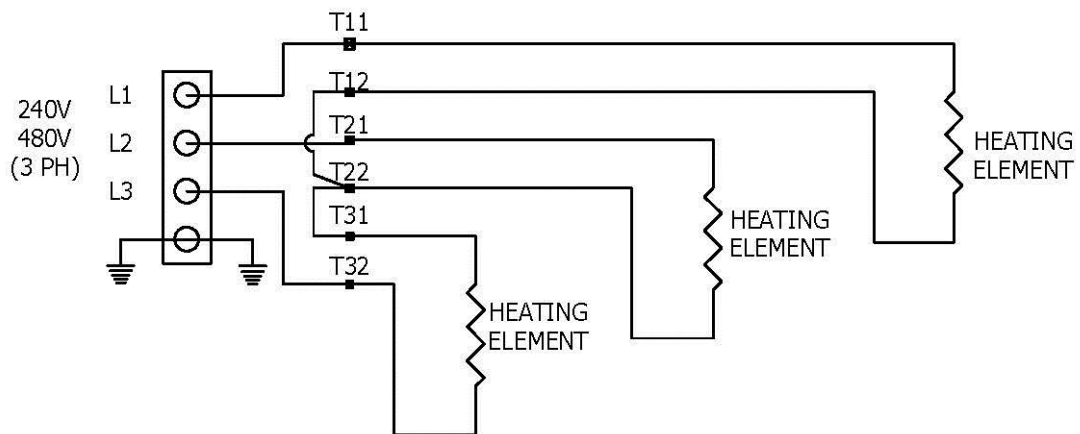
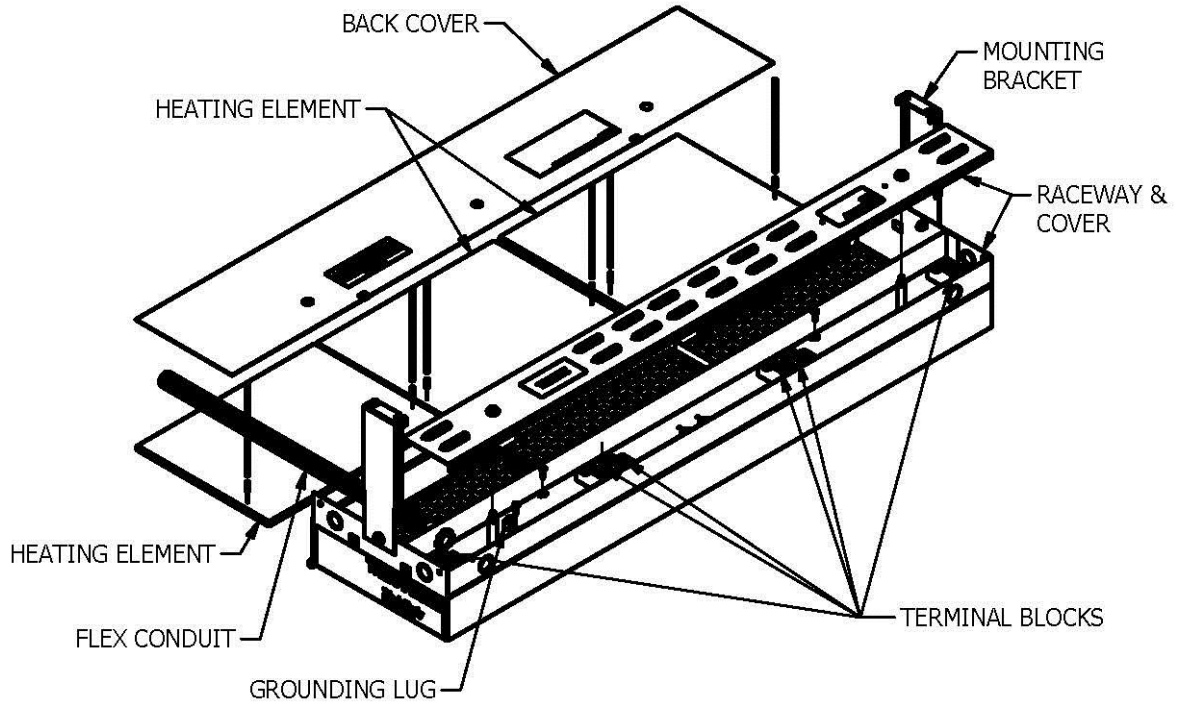



# INVIZATHERM THIN METHODS OF INSTALLATION:



Do not install the section closer than:

## INDOOR

- 36 inches to a vertical surface for vertical mounting
- 6-7/8 inches to a vertical surface for angled ceiling mounting
- 6-7/8 inches to a horizontal surface for wall mounting
- 12 inches to an adjacent vertical surface
- 36 inches to another heater
- 6 feet from the floor

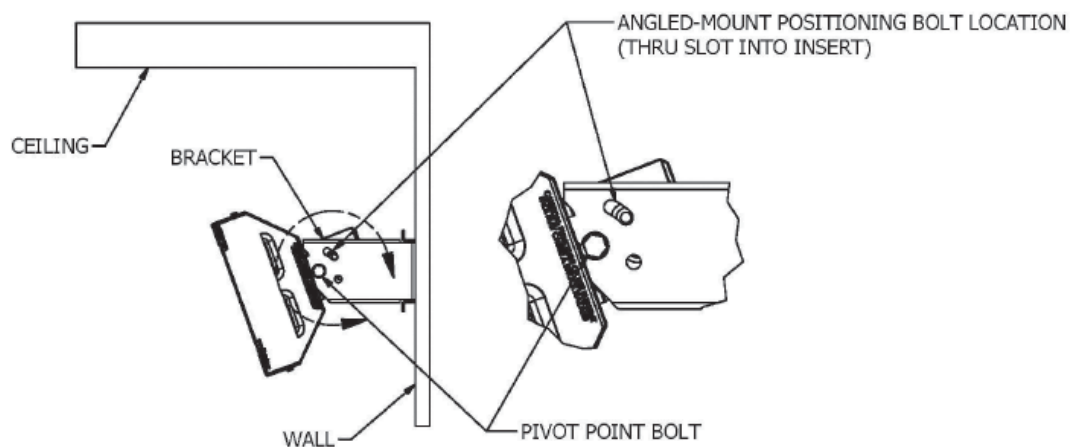

Fig. 1 – ANGLED POSITIONING FOR WALL MOUNTING



**WARNING! Risk of fire. Do not position any heater at an angle not allowed by the slotted hole (20°-45°).**

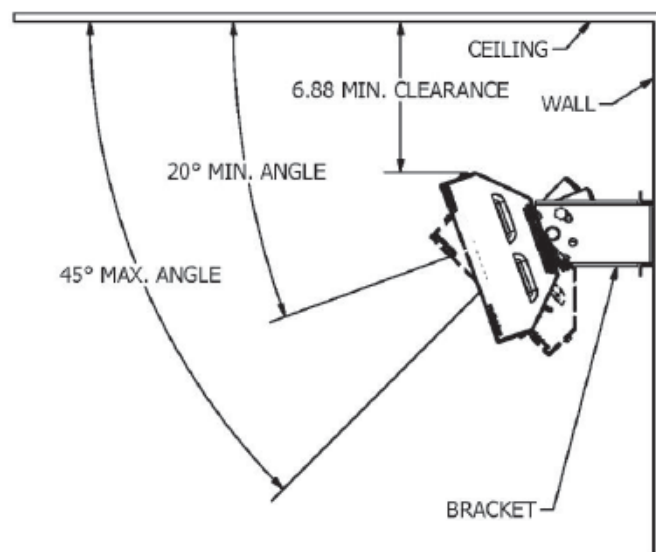
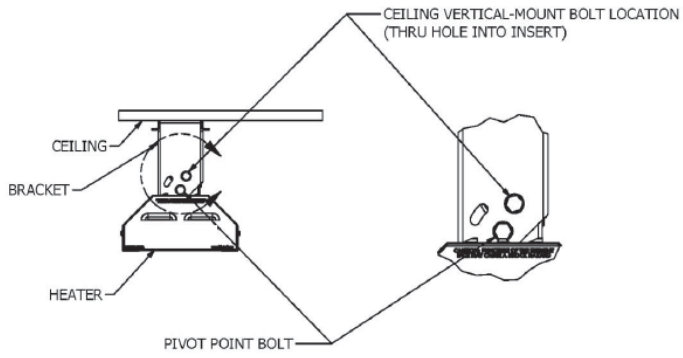
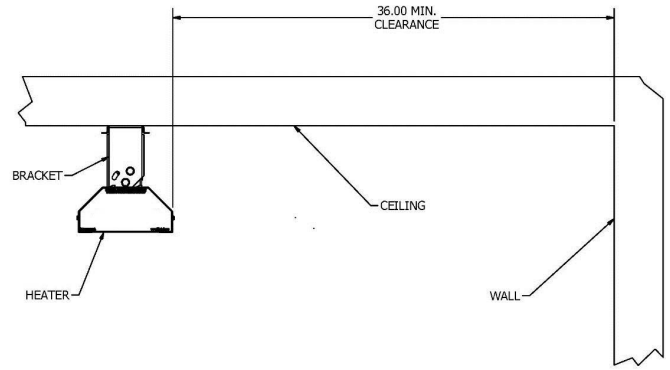

Fig. 2 – WALL MOUNTING



**Fig. 3 – CEILING ONLY VERTICAL MOUNTING POSITIONING**



**Fig. 4 – CEILING MOUNTING ANGLED AWAY FROM VERTICAL SURFACE**

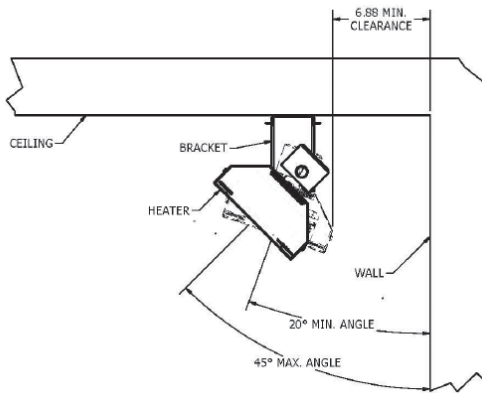

**Fig. 5 – CEILING MOUNTING VERTICAL**

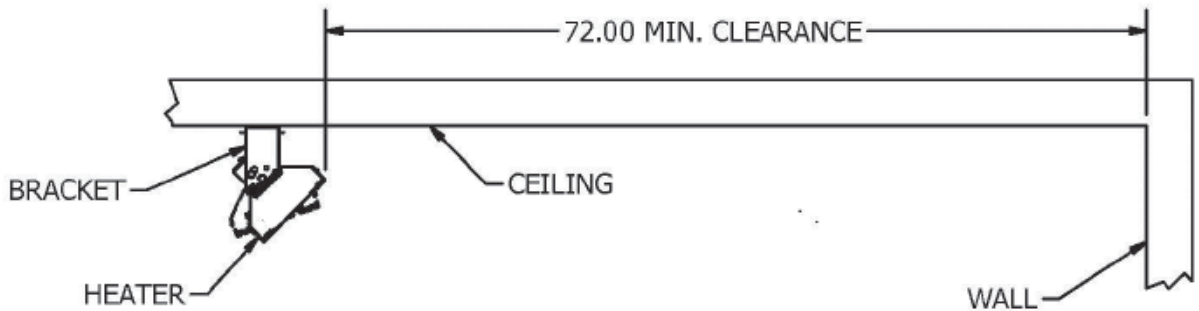

**Fig. 6 – CEILING MOUNTING ANGLED TOWARDS VERTICAL SURFACE**

# PROTECTED AREA

A *Protected Area* is defined as “Located in an area that is partially protected from the effects of weathering.” Typical *protected areas* would be the underside of a pavilion with a roof, garage port, and the like.

 Adhere to all mounting guidelines above. Additionally: no less than 12" from ledge.

The heater needs to be installed in a position such that it is protected from rain, snow, and similar outdoor wet areas.

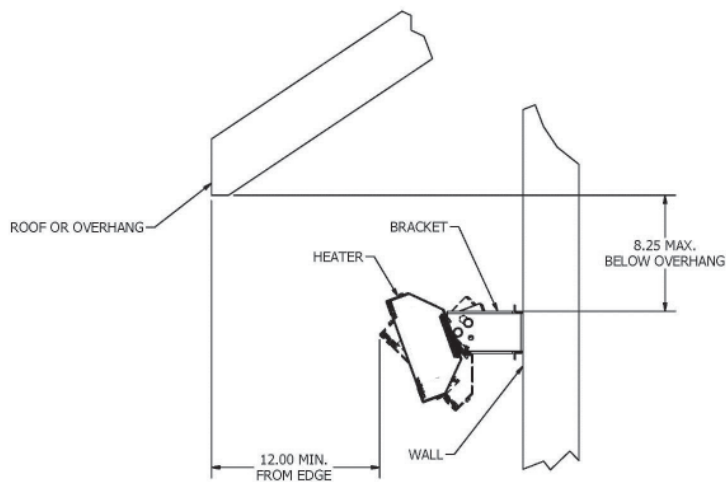

**Fig. 7 – PROTECTED AREA WALL MOUNTING**

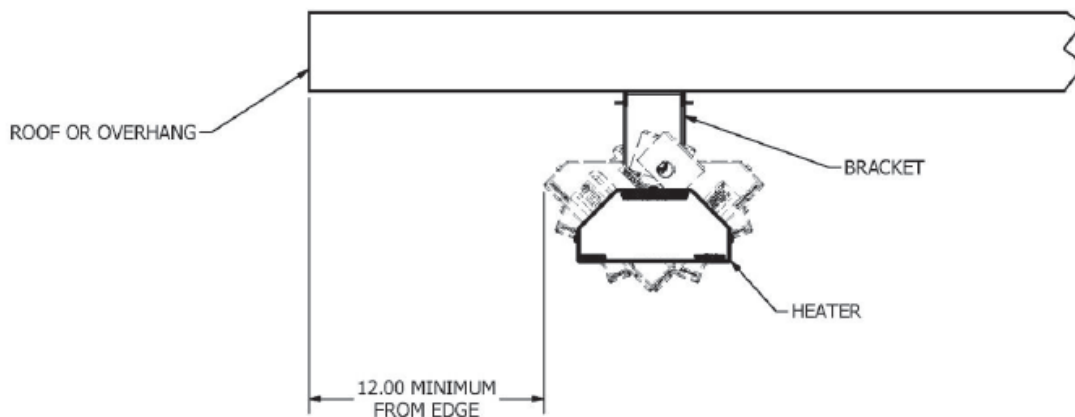

**Fig. 6 – PROTECTED AREA CEILING MOUNTING**

## Invizatherm Thin Infrared Heater Specifications

The electric infrared heater shall be InvizathermThin as manufactured by Indeeco, St. Louis, MO. The construction and design shall permit it to be ceiling or wall mounted, with the use of the mounting brackets supplied, or chain hung according to supplied instructions. Heaters shall include the features listed below.

**HEATING ASSEMBLY:** The heating assembly shall be cULus listed under standard 2021 and shall consist of single stranded, non-coiled Ni-Chrome wire embedded in vitrified ceramic fiber and backed with high density, low biopersistent Fiberfrax insulation. The emitting surface is covered with a black-coated high temperature fiberglass cloth.

**WIRING:** For connection to the power supply, Invizatherm heaters will include an indoor outdoor rate j-box mounted to the heaters raceway.

**CONSTRUCTION:** The heaters are formed and welded together out of 16 ga. and 20 ga. CRS or stainless steel. If CRS, the heater must be powder coated with a high temp black or white finish.



For supply connections use the wire size (or larger) as directed by the chart below. All wires must be suitable for at least 90°C (194°F).

SUPPLY CONNECTIONS		
MODEL NUMBER	120 VOLT AWG. WIRE SIZE	208/240 VOLT AWG. WIRE SIZE
STT-U18-1091B STT-U18-1330B	14	-
STT-U18-1767B	12	-
STT-U18-2161B	10	-
STT-U36-2180V STT-U36-2660V	-	14
STT-U36-3104V STT-U36-3534V	-	12
STT-U36-4322V	-	10

