

C70-7

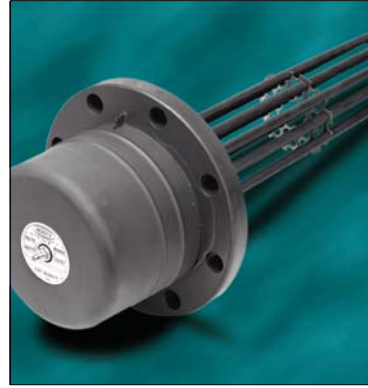

electric immersion heaters



electric heating and controls

Table Of Contents

Selection Guide.....	1-3
Quick Ship Pipe Thread Heaters	4-8
Construction Features	4
1" Pipe Thread Heaters	5
1-1/4" Pipe Thread Heaters	6
2" Pipe Thread Heaters	7
2-1/2" Pipe Thread Heaters	8
Stock Pipe Thread Heater	9
Pipe Thread Heaters.....	10-17
1" Pipe Thread Heaters	10
1-1/4" Pipe Thread Heaters	11-12
2" Pipe Thread Heaters	13-15
2-1/2" Pipe Thread Heaters	16-17
Heater Options.....	17
Flange Heaters	18-28
Construction Features	18-21
Water Heaters	22-24
Oil Heaters	25-26
Heater Options.....	27-28
Over-the-Side Heaters	29-31
Construction Features	29
Heater Options.....	29
Water Heaters	30
Oil Heaters	31
CSA Listed Explosion-proof Heaters	32-35
Construction Features	32
Temperature Code Calculations	33
Water Heaters	34
Oil Heaters	35
Tank and Basin Heaters	36-38
Pipe Insert Heaters	36
Deep Tank Heaters.....	36
Cooling Tower Heaters	37-38
Control Panels.....	39-41
Contactor Control Panels	39
SCR Control Panels.....	40
Cooling Tower Control Panels.....	41
Thermostats and Accessories	42-44
Special Purpose Heaters	45-46
Bottom-Mounted Heaters.....	45
Rectangular Flange Heaters	46
Series 770 Flange Heaters.....	46
Dimension Sheet for Pipe Thread Heaters	47-48
Limited Warranty	Back Cover

Selection Guide

Selection Guide

Heater construction is selected on the basis of the following criteria:

- Space Available for both elements and headers. If a great deal of heat must be concentrated in a small volume, one heater with multiple elements should be used. If it is desirable to distribute the heat over a large volume, multiple heaters should be installed at intervals along the vessel.
- Watt Density or watts per square inch of element surface area, compatible with the fluid heated and the maximum fluid temperature. See Table I for recommendations. The lower the watt density required, the larger the physical size of the heater.
- Structural Strength of the vessel, both for supporting the heater(s) and to maintain system pressure.
- Controllability, to determine how closely the temperature will be maintained. In addition to the selection of a control system it is often necessary to stage the heater to achieve good control. Distribution of heat also affects controllability.

Application Factors

Carry-over - Avoid contaminating the process with chemicals carried over from other processes. This can be particularly critical in plating and cleaning lines where parts may be dipped successively in different solutions.

Sludge - Be sure that heaters are located above the point of maximum sludge buildup since sludge will insulate the heater from the solution and cause premature failure.

Temperature - Control the process temperature as closely as possible. Excess temperature reduces heater life.

Heater Cycling - Match the heater wattage as closely as possible to the actual load requirements to limit on-off cycling.

Galvanic Action - Between the heater and adjacent metallic surfaces will cause premature heater failure and may similarly corrode the tank.

Maintenance - Routine heater maintenance will help prevent small problems from becoming serious. Heaters should be examined at regular intervals for corrosion and scale buildup.

Iron Content - In critical processes where no trace of iron can be tolerated, stainless steel heaters can be electropolished before installation.

Headers - In some applications, the header material can be as critical as the sheath material. In those cases, specify the header to match the sheath and specify "welded joints" if the solution will attack silver solder.

Calculating KW Capacity

In general, KW capacity will be determined by one of two factors: the heat required to bring the process up to temperature, and the heat required to maintain the process at operating temperature. Both requirements must be calculated; heaters are selected on the basis of the method that results in the higher KW rating.

For assistance in calculating the KW capacity for your job, consult your local INDEECO representative.

Watt Density And Sheath Selection

Watt density and sheath material are the two most critical factors affecting immersion heater life. Watt density (watts per square inch of heater surface area) determines heater operating temperature for a given set of fluid conditions. Sheath material similarly determines the rate of corrosion. Both vary with fluid temperature.

Table I has sheath materials recommended for each fluid and temperature. Those with an "A" rating have the best corrosion resistance, a "B" rating indicates fair resistance. Where a range of watt densities are shown, the lower end of the range represents a more conservative design.

The maximum watt density shown is 75 watts per square inch. In some applications, even higher watt densities may be suitable depending upon the details of the application (fluid velocity, contaminants in the fluid, space between elements, etc.). Consult your local INDEECO representative if a higher watt density is desired.

Since we specialize in custom-built industrial heating equipment, INDEECO can review your applications that are out of the ordinary, including heaters for immersion in fluids not shown in the table.

While Table I represents our most current knowledge, many application factors are beyond our control. Thus, this table should be used only as a guide. INDEECO cannot be responsible for heater failures due to corrosion.

Pipe Thread Heaters

Construction Features

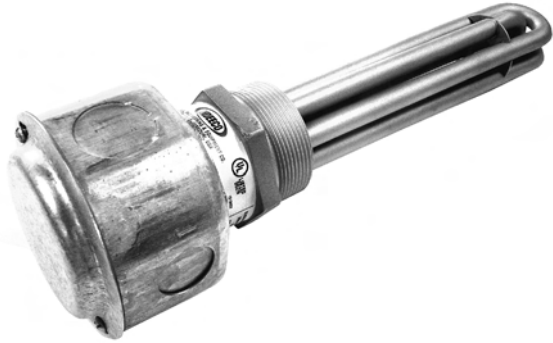

1" — 2-1/2" Pipe Thread Heaters

- Element bends repressed uniformly to insure electrical insulation integrity.
- One piece forging of hex, thread and riser assures reliability.
- Element spacers prevent hot spots.
- Bussing is permanent and encapsulated in epoxy seal.
- UL CSA label furnished on all standard copper, stainless steel and Incoloy sheathed heaters, NEMA Type 1, 4 and 4x environments.

Tubular Elements are welded or silver soldered into a hex head pipe thread fitting. Elements have 80/20 nickel-chromium resistance coils centered in a heavy gauge metal tube surrounded by magnesium oxide insulation. Through rolling, the magnesium oxide is compacted for rapid heat transfer from the coil to the sheath. Elements are annealed, bent and then 360° repressed to insure magnesium oxide integrity in the bent area.

1" and 1-1/4" pipe thread heaters have .312" diameter elements for operation up to 277 volts. 2" and 2-1/2" pipe thread heaters have .475" diameter elements suitable for operation up to 600 volts.

Pipe Thread Fittings of forged brass, silver soldered to the sheath, are furnished as standard with copper sheathed heaters. Steel and stainless steel sheathed elements are welded into fittings of like material.

Outlet Boxes are furnished on heaters without a built-in thermostat. A 4" NEMA 1 octagon outlet box having 3/4" knockouts is standard.

2" NPT stock heaters (without thermostats) are furnished with cast liquidproof outlet boxes.

Heaters with a built-in thermostat are normally furnished with a NEMA 1 rectangular sheet metal enclosure having combination 1/2"-3/4" knockouts. However, those heaters drawing more than 40 amps are furnished with welded steel outlet boxes having 1" or 1-1/4" hubs for electrical connections.

Built-In Thermostats provide automatic temperature control without the necessity of installing a separate well for the thermostat bulb in the field and making electrical connections between the heater and control. The thermostats are fully adjustable from 0-100/120° F, 40-120° F, or 60-250° F.

Standard thermostats are single-pole for single-phase heaters and for pilot duty three phase applications and two pole for de-energizing load carrying applications, see page 48 for selection criteria.

Heaters rated above these capacities require a magnetic contactor, with the thermostat controlling the contactor holding coil.

The thermostat's pilot duty rating is 250 VA at 277 volts maximum.

Element Spacers are made from Type 304 stainless steel to maintain a uniform distance between elements, thus preventing hot spots.

Epoxy Seals for a moisture resistant seal where fluid temperatures do not exceed 250° F.

UL and CSA Listings are available. All standard copper, Type 304 and 316 stainless steel and Incoloy sheathed heaters are listed by the Underwriters Laboratories under Reference E23541. These heaters, as well as steel sheathed heaters, are also available with the CSA (Canadian Standards Association) label under File No. LR11895. Some non-standard constructions can be UL and CSA labeled. Consult factory for availability.

Quick Ship Pipe Thread Heaters

1" NPT Pipe Thread Heaters

Quick ship, build your catalog number

7111A

Base number from chart below

304 SS Sheath, 304 SS Fitting 50 / 37.5 W/Sq.In.

Elements	KW	B Dimension (Inches)	Catalog Number	Watts/in ²	1 Phase		
					120V	208V	240V
1	.45	8-1/2	5A6	37.5		C	
	.60	8-1/2	5B6	50.0			J
	.75	11-7/8	5C6	37.5		C	
	1.00	11-7/8	5D6	50.0			J
	1.25	18-3/4	5E6	37.5		C	
	1.67	18-3/4	5F6	50.0			J
	1.88	27-1/4	5G6	37.5		C	
	2.50	27-1/4	5H6	50.0			J
	3.00	42-1/2	5I6	37.5		C	
	4.00	42-1/2	5J6	50.0			J

304 SS Sheath, Steel Fitting 20 / 15 W/Sq.In.

Elements	KW	B Dimension (Inches)	Catalog Number	Watts/in ²	1 Phase		
					120V	208V	240V
1	.38	14-1/2	5K6	15		C	
	.50	14-1/2	5L6	20			J
	.75	27-1/4	5M6	15		C	
	1.00	27-1/4	5N6	20			J
	1.25	44-1/4	5O6	15		C	
	1.67	44-1/4	5P6	20			J

Select letter indicating voltage/phase from chart

Thermostat Range
 0= No thermostat
 2= 60-250° F
 3= 0-100/120° F

Thermostat Style
 0= No thermostat
 1= Single pole
 2= Two pole

Terminal Box
 1= Nema 1
 2= NEMA 4
 5= NEMA 4/12 painted steel
 6= NEMA 4X fiberglass

Quick Ship Pipe Thread Heaters

1-1/4" NPT Pipe Thread Heaters

Quick ship, build your catalog number

7121A

Base number from chart below

304 SS Sheath, 304 SS Fitting

50 / 37.5 W/Sq.In.

Elements	KW	B Dimension (Inches)	Catalog Number	Watts/ in2	1 Phase			3 Phase	
					120V	208V	240V	208V	240V
3	1.35	8-1/2	6A6	37.5		C		D	
	1.80	8-1/2	6B6	50.0			J		K
	2.25	11-7/8	6C6	37.5		C		D	
	3.00	11-7/8	6D6	50.0			J		K
	3.75	18-3/4	6E6	37.5		C		D	
	5.00	18-3/4	6F6	50.0			J		K
	5.63	27-1/4	6G6	37.5		C		D	
	7.50	27-1/4	6H6	50.0			J		K
	9.00	42-1/2	6I6	37.5		C		D	
	12.00	42-1/2	6J6	50.0			J		K

304 SS Sheath, Steel Fitting

20 / 15 W/Sq.In.

Elements	KW	B Dimension (Inches)	Catalog Number	Watts/ in2	1 Phase			3 Phase	
					120V	208V	240V	208V	240V
3	1.10	14-1/2	6L6	15		C		D	
	1.50	14-1/2	6M6	20			J		K
	2.25	27-1/4	6N6	15		C		D	
	3.00	27-1/4	6O6	20			J		K
	3.75	44-1/4	6P6	15		C		D	
	5.00	44-1/4	6Q6	20			J		K

Select letter indicating voltage/phase from chart

Thermostat Range
 0= No thermostat
 2= 60-250° F
 3= 0-100/120° F

Thermostat Style
 0= No thermostat
 1= Single pole
 2= Two pole

Terminal Box
 1= Nema 1
 2= NEMA 4
 5= NEMA 4/12 painted steel
 6= NEMA 4X fiberglass

Quick Ship Pipe Thread Heaters

2" NPT Pipe Thread Heaters

Quick ship, build your catalog number

7131

Base number from chart below

304 SS Sheath, 304 SS Fitting

50 / 37.5 W/Sq.In.

Elements	KW	B Dimension (Inches)	Catalog Number	Watts/ in2	1 Phase				3 Phase		
					120V	208V	240V	480V	208V	240V	480V
3	2.25	8-1/2	A7A6	37.5			J			K	
	3.00	8-1/2	A7B6	50.0		C			D		U
	3.75	13	A7C6	37.5			J			K	
	5.00	13	A7D6	50.0		C			D		U
	5.60	18-1/2	A7E6	37.5			J			K	
	7.50	18-1/2	A7F6	50.0		C			D		U
	9.00	28-3/4	A7G6	37.5			J			K	
	10.00	24-1/4	A7H6	50.0		C			D		U
	11.20	35-1/2	A7I6	37.5			J			K	
	12.00	28-1/2	A7J6	50.0		C			D		U
	13.50	42	A7K6	37.5			J			K	
	15.00	35-1/2	A7L6	50.0							U
18.00	42	A7M6	50.0							U	

Select letter indicating voltage/phase from chart

Thermostat Range
 0= No thermostat
 2= 60-250° F
 3= 0-100/120° F

Copper Sheath, Brass Fitting

50 W/Sq.In.

Elements	KW	B Dimension (Inches)	Catalog Number	Watts/ in2	1 Phase				3 Phase		
					120V	208V	240V	480V	208V	240V	480V
3	3	8-1/4	A7N1	50		C			D		U
	4	10-1/2	A7O1	50		C			D		U
	5	12-3/4	A7P1	50		C			D		U
	6	15	A7Q1	50		C			D		U
	7	17-1/4	A7R1	50		C			D		U
	8	19-1/2	A7S1	50		C			D		U
	9	21-3/4	A7T1	50							U
	10	24	A7U1	50							U
	12	28-1/2	A7V1	50		C			D		U
	15	35-1/4	A7W1	50							U
	16	37-3/4	A7X1	50							U

Thermostat Style
 0= No thermostat
 1= Single pole
 2= Two pole

Terminal Box
 1= Nema 1
 2= NEMA 4
 5= NEMA 4/12 painted steel
 6= NEMA 4X fiberglass

304 SS Sheath, Steel Fitting

20/15 W/Sq.In.

Elements	KW	B Dimension (Inches)	Catalog Number	Watts/ in2	1 Phase				3 Phase		
					120V	208V	240V	480V	208V	240V	480V
3	2.25	18-3/4	C8A6	15			J			K	
	3.00	18-3/4	C8B6	20		C			D		U
	3.75	29-3/4	C8C6	15			J			K	
	5.00	29-3/4	C8D6	20		C			D		U
	5.60	49-3/4	C8E6	15			J			K	
	7.50	43-3/4	C8F6	20		C			D		U
	9.00	69	C8G6	15			J			K	
	10.00	57-3/4	C8H6	20		C			D		U
	12.00	69	C8I6	20		C			D		U

Quick Ship Pipe Thread Heaters

2 1/2" NPT Pipe Thread Heaters

Quick ship, build your catalog number

7141A

Base number from chart below

304 SS Sheath, 304 SS Fitting

50 / 37.5 W/Sq.In.

Elements	KW	B Dimension (Inches)	Catalog Number	Watts/ in2	1 Phase				3 Phase			
					120V	208V	240V	480V	208V	240V	480V	
3	2.25	8-1/2	9A6	37.5			J			K		
	3.00	8-1/2	9B6	50.0		C			D		U	
	3.75	13	9C6	37.5			J			K		
	5.00	13	9D6	50.0		C			D		U	
	5.60	18-1/2	9E6	37.5			J			K		
	7.50	18-1/2	9F6	50.0		C			D		U	
	9.00	28-3/4	9G6	37.5			J			K		
	10.00	24-1/4	9H6	50.0		C			D		U	
	11.20	35-1/2	9I6	37.5			J			K		
	12.00	28-3/4	9J6	50.0		C			D		U	
	13.50	42	9K6	37.5			J			K		
	15.00	35-1/2	9L6	50.0								U
	18.00	42	9M6	50.0								U

304 SS Sheath, Steel Fitting

50 W/Sq.In.

Elements	KW	B Dimension (Inches)	Catalog Number	Watts/ in2	1 Phase				3 Phase			
					120V	208V	240V	480V	208V	240V	480V	
3	2.25	8-1/4	9N1	15			J			K		
	3.00	8-3/4	9O1	20		C			D		U	
	3.75	29-3/4	9P1	15			J			K		
	5.00	29-3/4	9Q1	20		C			D		U	
	5.60	43-3/4	9R1	15			J			K		
	7.50	43-3/4	9S1	20		C			D		U	
	9.00	69	9T1	15			J			K		
	10.00	57-3/4	9U1	20		C			D		U	
	12.00	69	9V1	20		C			D		U	

Select letter indicating voltage/phase from chart

Thermostat Range
 0= No thermostat
 2= 60-250° F
 3= 0-100/120° F

Thermostat Style
 0= No thermostat
 1= Single pole
 2= Two pole

Terminal Box
 1= Nema 1
 2= NEMA 4
 5= NEMA 4/12 painted steel
 6= NEMA 4X fiberglass

Stock Pipe Thread Heaters

2" Pipe Thread Heaters

Water

304 SS Sheath, 304 SS Fitting

50 W/Sq.In.

Number of Elements	KW	Stock Without Thermostat, NEMA 4 Terminal Box				
		B Dimension (Inches)	Catalog Number	Availability		
				3 Phase		
208V	240V	480V				
3	4.5	11-3/4	S7131A066208U	•	•	S
	6.0	15-1/4	S7131A086208U	•	•	S
	7.5	18-1/2	S7131A096208U	•	•	S
	9.0	21-3/4	S7131A106208U	•	•	S
	12.0	28-1/2	S7131A116208U	•	•	S
	15.0	35-1/4	S7131A126208U	•	•	S
	18.0	42	S7131A136208U			S



Copper Sheath, Brass Fitting

50 W/Sq.In.

Number of Elements	KW	Stock Without Thermostat, NEMA 4 Terminal Box				
		B Dimension (Inches)	Catalog Number	Availability		
				3 Phase		
208V	240V	480V				
3	3	8-1/4	S7131A141200D	S	•	
	3	8-1/4	S7131A141200U		•	S
	4	10-1/2	S7131A151200D	S	•	
	4	10-1/2	S7131A151200U		•	S
	5	12-3/4	S7131A171200D	S	•	
	5	12-3/4	S7131A171200U		•	S
	6	15	S7131A201200D	S	•	
	6	15	S7131A201200U		•	S
	7	17-1/4	S7131A221200D	S	•	
	7	17-1/4	S7131A221200U		•	S
	8	19-1/2	S7131A281200D	S	•	
	8	19-1/2	S7131A281200U		•	S
	9	21-3/4	S7131A291200D	S	•	
	9	21-3/4	S7131A291200U	•	•	S
	10	24	S7131A301200D	S	•	
	10	24	S7131A301200U	•	•	S
	12	28-1/2	S7131A321200D	S	•	
	12	28-1/2	S7131A321200U		•	S
	15	35-1/4	S7131A331200U		•	S
16	37-3/4	S7131A341200U	•		S	

Pipe Thread Heaters

1" Pipe Thread Heaters

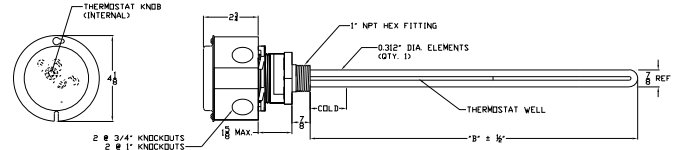
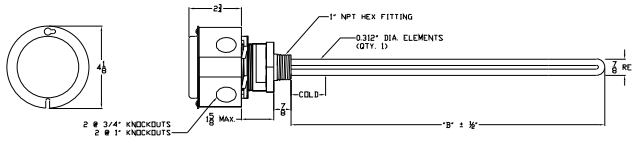

Water

304 SS Sheath, 304 SS Fitting

50 W/Sq. In.

Number of Elements	KW	Without Thermostat, NEMA 1 Terminal Box			Availability		
		B Dimensions (Inches)	Catalog Number	1 Phase			
				120V	208V	240V	
1	.5	6-1/2	7111N016	•	•		
	.6	7-1/2	7111N026	•	•	•	
	.75	9	7111N036	•	•	•	
	.85	10	7111N046	•	•	•	
	1	11-1/2	7111N056	•	•	•	
	1.25	14	7111N066	•	•	•	
	1.5	16-1/2	7111N076	•	•	•	
	2	21-3/4	7111N086	•	•	•	
	2.5	26-3/4	7111N096	•	•	•	
	3	32	7111N106	•	•	•	
4	42-1/4	7111N116	•	•	•		

With Built-In Thermostat, NEMA 1 Terminal Box			Availability		
B Dimensions (Inches)	Catalog Number	1 Phase			
		120V	208V	240V	
7-1/2	7111N126	•	•		
8-1/2	7111N136	•	•	•	
10	7111N146	•	•	•	
11	7111N156	•	•	•	
12-1/2	7111N166	•	•	•	
15-1/4	7111N176	•	•	•	
17-3/4	7111N186	•	•	•	
22-3/4	7111N196	•	•	•	
28	7111N206	•	•	•	
33	7111N216	•	•	•	
43-1/4	7111N226	•	•	•	

Please specify volts, phase, terminal box rating and, if needed, thermostat range from options listed on page 16.

Oil

304SS Sheath, 304 SS Fitting

20 W/Sq. In.

Number of Elements	KW	Without Thermostat, NEMA 1 Terminal Box			Availability		
		B Dimensions (Inches)	Catalog Number	1 Phase			
				120V	208V	240V	
1	.25	7-1/2	7111N204	•			
	.3	9	7111N214	•	•		
	.375	10-3/4	7111N224	•	•	•	
	.425	12	7111N234	•	•	•	
	.5	14	7111N244	•	•	•	
	.625	17	7111N254	•	•	•	
	.75	20-1/4	7111N264	•	•	•	
	1	26-3/4	7111N274	•	•	•	
	1.5	39-1/2	7111N284	•	•	•	
	2	52-1/4	7111N294	•	•	•	

With Built-In Thermostat, NEMA 1 Terminal Box			Availability		
B Dimensions (Inches)	Catalog Number	1 Phase			
		120V	208V	240V	
7-1/2	7111N304	•			
9	7111N314	•	•		
10-3/4	7111N324	•	•	•	
12	7111N334	•	•	•	
14	7111N344	•	•	•	
17	7111N354	•	•	•	
20-1/4	7111N364	•	•	•	
26-3/4	7111N374	•	•	•	
39-1/2	7111N384	•	•	•	
52-1/4	7111N394	•	•	•	

Please specify volts, phase, terminal box rating and, if needed, thermostat range from options listed on page 17.

Pipe Thread Heaters

1-1/4" Pipe Thread Heaters

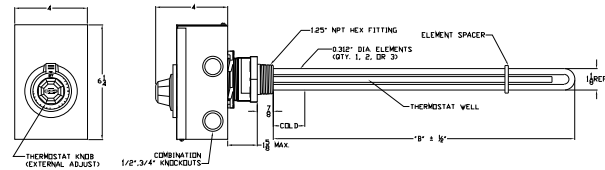
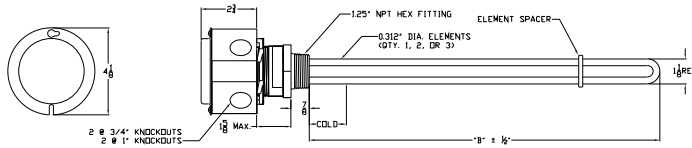

Water

304 SS Sheath, 304 SS Fitting

50 W/Sq. In.

Number of Elements	KW	Without Thermostat, NEMA 1 Terminal Box								
		B Dimensions (Inches)	Catalog Number	Availability						
				1 Phase			3 Phase			
				120V	208V	240V	480V	208V	240V	480V
1	.6	7-1/2	7121U116	•	•	•				
	.75	9	7121U126	•	•	•				
	1	11-1/2	7121U136	•	•	•				
	1.5	16-1/2	7121U146	•	•	•				
	2	21-3/4	7121U156	•	•	•				
	2.5	26-3/4	7121U166	•	•	•				
	3	32	7121U176	•	•	•				
	4	42	7121U186	•	•	•				
2	1.2	7-1/2	7121U306	•	•	•				
	1.5	9	7121U316	•	•	•				
	2	11-1/2	7121U326	•	•	•				
	2.5	14	7121U336	•	•	•				
	3	16-1/2	7121U346	•	•	•				
	3.5	19-1/4	7121U356	•	•	•				
	4	21-3/4	7121U366	•	•	•				
	5	26-3/4	7121U376	•	•	•				
3	1.5	6-1/4	7121U496	•	•			•		
	1.8	7-1/2	7121U506	•	•	•		•	•	
	3	11-1/2	7121U516	•	•	•		•	•	
	3.75	14	7121U526	•	•	•		•	•	
	4.5	16-1/2	7121U536	•	•	•		•	•	
	5.25	19-1/4	7121U546		•	•		•	•	
	6	21-3/4	7121U556		•	•		•	•	
	7.5	26-3/4	7121U566		•	•		•	•	
	9	32	7121U576		•	•		•	•	
	12	42	7121U586		•	•		•	•	

B Dimensions (Inches)	Catalog Number*	With Built-In Thermostat, NEMA 1 Terminal Box						
		Availability						
		1 Phase			3 Phase			
		120V	208V	240V	480V	208V	240V	480V
8-3/4	7121U216	•	•	•				
10-1/4	7121U226	•	•	•				
12-3/4	7121U236	•	•	•				
18	7121U246	•	•	•				
23	7121U256	•	•	•				
28-1/4	7121U266	•	•	•				
33-1/4	7121U276	•	•	•				
43-1/2	7121U286	•	•	•				
8-3/4	7121U406	•	•	•				
10-1/4	7121U416	•	•	•				
12-3/4	7121U426	•	•	•				
15-1/2	7121U436	•	•	•				
18	7121U446	•	•	•				
20-1/2	7121U456	•	•	•				
23	7121U466	•	•	•				
28-1/4	7121U476	•	•	•				
33-1/4	7121U486	•	•	•				
7-3/4	7121U596	•	•			•		
8-3/4	7121U606	•	•	•		•	•	
12-3/4	7121U616	•	•	•		•	•	
15-1/2	7121U626	•	•	•		•	•	
18	7121U636	•	•	•		•	•	
20-1/2	7121U646	•	•	•		•	•	
23	7121U656	•	•	•		•	•	
28-1/4	7121U666	•	•	•		•	•	
33-1/4	7121U676	•	•	•		•	•	
43-1/4	7121U686	•	•	•		•	•	

Please specify volts, phase, terminal box rating and, if needed, thermostat range from options listed on page 17.

*UL Listing is available with thermostat built-in NEMA 1 Box only. For all other terminal box options, use 712N designation.



Pipe Thread Heaters

1-1/4" Pipe Thread Heaters

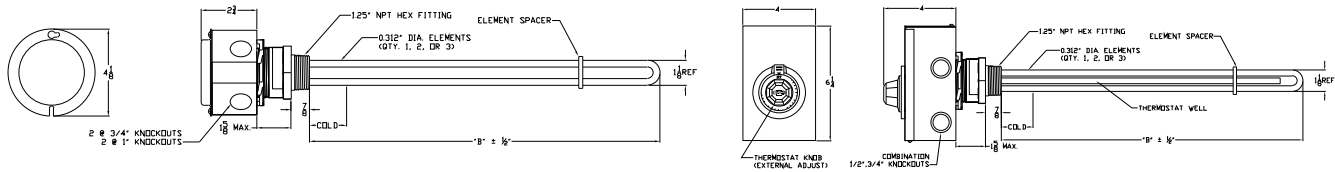

Oil

304 SS Sheath, 304 SS Fitting

20 W/Sq. In.

Number of Elements	KW	Without Thermostat, NEMA 1 Terminal Box									
		B Dimensions (Inches)	Catalog Number	Availability							
				1 Phase		3 Phase					
120V	208V	240V	480V	208V	240V	480V					
1	.25	7-3/4	7121U404	•							
	.375	10-3/4	7121U414	•	•	•					
	.5	14	7121U424	•	•	•					
	.75	20-1/2	7121U434	•	•	•					
	1	26-3/4	7121U444	•	•	•					
	1.25	33-1/4	7121U454	•	•	•					
	1.5	39-1/2	7121U464	•	•	•					
	2	52-1/4	7121U474	•	•	•					
2	.5	7-3/4	7121U564	•							
	.75	10-3/4	7121U574	•	•	•					
	1	14	7121U584	•	•	•					
	1.25	17-1/4	7121U594	•	•	•					
	1.5	20-1/2	7121U604	•	•	•					
	1.75	23-1/2	7121U614	•	•	•					
	2	26-3/4	7121U624	•	•	•					
	2.5	33-1/4	7121U634	•	•	•					
	3	39-1/2	7121U644	•	•	•					
4	52-1/4	7121U654	•	•	•						
3	1.5	14	7121U764	•	•	•		•	•		
	2.25	20-1/4	7121U774	•	•	•		•	•		
	3	26-3/4	7121U784	•	•	•		•	•		
	3.75	33-1/4	7121U794	•	•	•		•	•		
	4.5	39-1/2	7121U804	•	•	•		•	•		
	6	52-1/4	7121U814	•	•	•		•	•		

B Dimensions (Inches)	Catalog Number*	With Built-In Thermostat, NEMA 1 Terminal Box					
		Availability					
		1 Phase		3 Phase			
120V	208V	240V	480V	208V	240V	480V	
7-3/4	7121U484	•					
10-3/4	7121U494	•	•	•			
14	7121U504	•	•	•			
20-1/2	7121U514	•	•	•			
26-3/4	7121U524	•	•	•			
33-1/4	7121U534	•	•	•			
39-1/2	7121U544	•	•	•			
52-1/4	7121U554	•	•	•			
7-3/4	7121U664	•					
10-3/4	7121U674	•	•	•			
14	7121U684	•	•	•			
17-1/4	7121U694	•	•	•			
20-1/2	7121U704	•	•	•			
23-1/2	7121U714	•	•	•			
26-3/4	7121U724	•	•	•			
33-1/4	7121U734	•	•	•			
39-1/2	7121U744	•	•	•			
52-1/4	7121U754	•	•	•			
14	7121U824	•	•	•		•	•
20-1/4	7121U834	•	•	•		•	•
26-3/4	7121U844	•	•	•		•	•
33-1/4	7121U854	•	•	•		•	•
39-1/2	7121U864	•	•	•		•	•
52-1/4	7121U874	•	•	•		•	•

Please specify volts, phase, terminal box rating and, if needed, thermostat range from options listed on page 17.

*UL Listing is available with thermostat built-in NEMA 1 Box only. For all other terminal box options, use 712N designation.

Pipe Thread Heaters

2" Pipe Thread Heaters

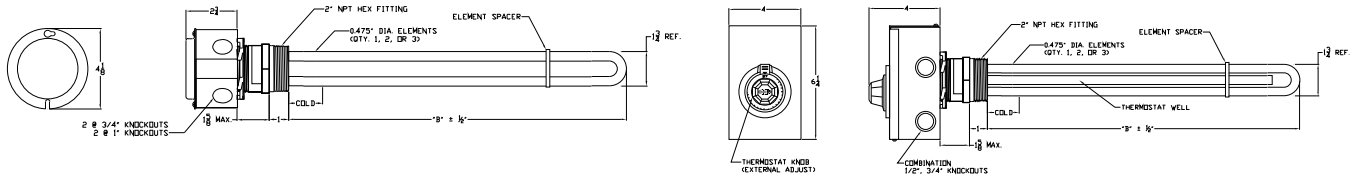

Water

304 SS Sheath, 304 SS Fitting

50 W/Sq. In.

Number of Elements	KW	Without Thermostat, NEMA 1 Terminal Box								
		B Dimensions (Inches)	Catalog Number	Availability						
				1 Phase		3 Phase				
120V	208V	240V	480V	208V	240V	480V				
1	1	8-1/2	7131U146	•	•	•				
	1.5	11-3/4	7131U056	•	•	•	•			
	2	15-1/4	7131U076	•	•	•	•			
	2.5	18-1/2	7131U156	•	•	•	•			
	3	21-3/4	7131U166	•	•	•	•			
	4	28-1/2	7131U176	•	•	•	•			
	5	35-1/4	7131U186		•	•	•			
6	42	7131U196		•	•	•				
2	2	8-1/2	7131U236	•	•	•				
	2.5	10	7131U246	•	•	•	•			
	3	11-3/4	7131U256	•	•	•	•			
	3.5	13-1/2	7131U206	•	•	•	•			
	4	15-1/4	7131U216	•	•	•	•			
	5	18-1/2	7131U226		•	•	•			
	6	21-3/4	7131U316		•	•	•			
	8	28-1/2	7131U266		•	•	•			
10	35-1/4	7131U376				•				
12	42	7131U276				•				
3	3	8-1/2	7131U286	•	•	•	•	•	•	•
	3.75	10	7131U296	•	•	•	•	•	•	•
	4.5	11-3/4	7131U306	•	•	•	•	•	•	•
	5.25	13-1/2	7131U326		•	•	•	•	•	•
	6	15-1/4	7131U346		•	•	•	•	•	•
	7.5	18-1/2	7131U356		•	•	•	•	•	•
	9	21-3/4	7131U366		•	•	•	•	•	•
	12	28-1/2	7131U386				•	•	•	•
	15	35-1/4	7131U396					•	•	•
	18	42	7131U406					•	•	•

With Built-In Thermostat, NEMA 1 Terminal Box							
B Dimensions (Inches)	Catalog Number*	Availability					
		1 Phase		3 Phase			
120V	208V	240V	480V	208V	240V	480V	
8-1/2	7131U416	•	•	•			
11-3/4	7131U426	•	•	•	•		
15-1/4	7131U436	•	•	•	•		
18-1/2	7131U446	•	•	•	•		
21-3/4	7131U456	•	•	•	•		
28-1/2	7131U466	•	•	•	•		
35-1/4	7131U476		•	•	•		
42	7131U486		•	•	•		
8-1/2	7131U496	•	•	•			
10	7131U506	•	•	•	•		
11-3/4	7131U516	•	•	•	•		
13-1/2	7131U526	•	•	•	•		
15-1/4	7131U536	•	•	•	•		
18-1/2	7131U546		•	•	•		
21-3/4	7131U556		•	•	•		
28-1/2	7131U566		•	•	•		
35-1/4	7131U576				•		
42	7131U586				•		
8-1/2	7131U596	•	•	•		•	•
10	7131U606	•	•	•		•	•
11-3/4	7131U616	•	•	•	•	•	•
13-1/2	7131U626	•	•	•	•	•	•
15-1/4	7131U636	•	•	•	•	•	•
18-1/2	7131U646	•	•	•	•	•	•
21-3/4	7131U656		•	•	•	•	•
28-1/2	7131U676				•	•	•
35-1/4	7131U686					•	•
42	7131U696					•	•

Please specify volts, phase, terminal box rating and, if needed, thermostat range from options listed on page 17.

*UL Listing is available with thermostat built-in NEMA 1 Box only. For all other terminal box options, use 713N designation.



Pipe Thread Heaters

2" Pipe Thread Heaters

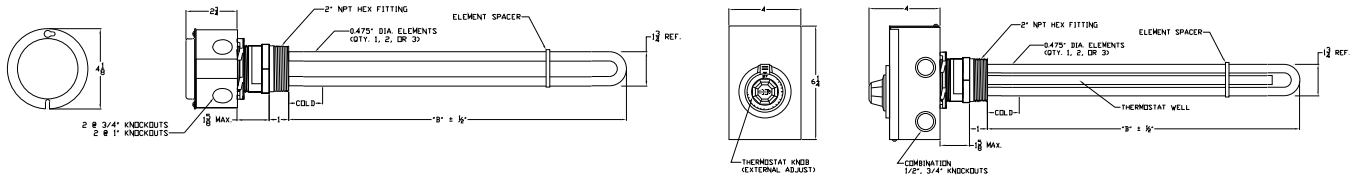

Water

Copper Sheath, Brass Fitting

50 W/Sq. In.

Number of Elements	KW	Without Thermostat, NEMA 1 Terminal Box								
		B Dimensions (Inches)	Catalog Number	Availability						
				1 Phase			3 Phase			
				120V	208V	240V	480V	208V	240V	480V
1	1	8-1/4	7131U361	•	•	•				
	1.5	11-3/4	7131U051	•	•	•	•			
	2	15	7131U071	•	•	•	•			
	2.5	18-1/4	7131U371	•	•	•	•			
	3	21-3/4	7131U381	•	•	•	•			
	4	28-1/2	7131U391	•	•	•	•			
	5	35-1/4	7131U401		•	•	•			
	6	41-3/4	7131U411		•	•	•			
2	2	8-1/4	7131U231	•	•	•				
	2.5	10	7131U241	•	•	•	•			
	3	11-3/4	7131U501	•	•	•	•			
	3.5	13-1/4	7131U511	•	•	•	•			
	4	15	7131U271	•	•	•	•			
	5	18-1/4	7131U521		•	•	•			
	6	21-3/4	7131U311		•	•	•			
	8	28-1/2	7131U531		•	•	•			
	10	35-1/4	7131U541				•			
	12	41-3/4	7131U551				•			
3	3	8-1/4	7131U621	•	•	•		•	•	
	3.75	10	7131U631	•	•	•	•	•	•	•
	4	10-1/2	7131U641	•	•	•	•	•	•	•
	4.5	11-3/4	7131U651	•	•	•	•	•	•	•
	5	12-3/4	7131U661		•	•	•	•	•	•
	5.25	13-1/4	7131U671		•	•	•	•	•	•
	6	15	7131U681		•	•	•	•	•	•
	7	17-1/4	7131U691		•	•	•	•	•	•
	7.5	18-1/4	7131U701		•	•	•	•	•	•
	8	19-1/2	7131U711		•	•	•	•	•	•
	9	21-3/4	7131U721				•	•	•	•
	10	24	7131U731				•	•	•	•
	12	28-1/2	7131U741				•	•	•	•
	15	35-1/4	7131U751						•	•
	16	37-3/4	7131U761							•
	18	41-3/4	7131U771							•

With Built-In Thermostat, NEMA 1 Terminal Box									
B Dimensions (Inches)	Catalog Number*	Availability							
		1 Phase			3 Phase				
		120V	208V	240V	480V	208V	240V	480V	
9-1/4	7131U421	•	•	•					
12-3/4	7131U431	•	•	•	•				
16	7131U441	•	•	•	•				
19-1/2	7131U451	•	•	•	•				
22-3/4	7131U461	•	•	•	•				
29-1/2	7131U471	•	•	•	•				
36-1/4	7131U481		•	•	•				
43	7131U491		•	•	•				
9-1/4	7131U181	•	•	•					
11	7131U561	•	•	•	•				
12-3/4	7131U251	•	•	•	•				
14-1/4	7131U571	•	•	•	•				
16	7131U191	•	•	•	•				
19-1/2	7131U581		•	•	•				
22-3/4	7131U211		•	•	•				
29-1/2	7131U591		•	•	•				
36-1/4	7131U601				•				
43	7131U611				•				
9-1/4	7131U781	•	•	•		•	•		
11	7131U791	•	•	•	•	•	•	•	•
11-1/2	7131U801	•	•	•	•	•	•	•	•
12-3/4	7131U811	•	•	•	•	•	•	•	•
13-3/4	7131U821	•	•	•	•	•	•	•	•
14-1/4	7131U831	•	•	•	•	•	•	•	•
16	7131U841		•	•	•	•	•	•	•
18-1/4	7131U851		•	•	•	•	•	•	•
19-1/2	7131U861		•	•	•	•	•	•	•
20-1/2	7131U871		•	•	•	•	•	•	•
22-3/4	7131U881		•	•	•	•	•	•	•
25	7131U891				•	•	•	•	•
29-1/2	7131U901				•	•	•	•	•
36-1/4	7131U911						•	•	
38-1/4	7131U921							•	
43	7131U931								•

Please specify volts, phase, terminal box rating and, if needed, thermostat range from options listed on page 17.

*UL Listing is available with thermostat built-in NEMA 1 Box only. For all other terminal box options, use 713N designation.

Pipe Thread Heaters

2" Pipe Thread Heaters

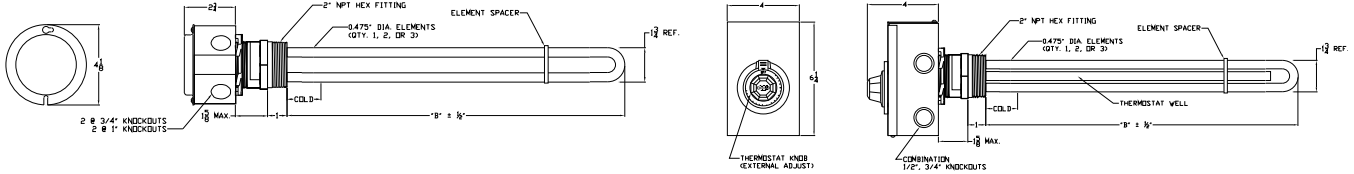

Oil

Steel Sheath, Steel Fitting

20 W/Sq. In.

Number of Elements	KW	Without Thermostat, NEMA 1 Terminal Box		Availability							
		B Dimensions (Inches)	Catalog Number	1 Phase			3 Phase				
				120V	208V	240V	480V	208V	240V	480V	
1	1	18-1/2	7131U234	•	•	•	•				
	1.5	27	7131U244	•	•	•	•				
	2	35-1/4	7131U254	•	•	•	•				
	2.5	43-3/4	7131U264	•	•	•	•				
	3	52	7131U274	•	•	•	•				
2	1	10	7131U334	•	•	•					
	1.5	14-1/4	7131U034	•	•	•	•				
	1.75	16-1/4	7131U354	•	•	•	•				
	2	18-1/2	7131U364	•	•	•	•				
	2.25	20-1/2	7131U374	•	•	•	•				
	2.5	22-3/4	7131U384	•	•	•	•				
	3	27	7131U064	•	•	•	•				
	4	35-1/4	7131U084	•	•	•	•				
	5	43-3/4	7131U104		•	•	•				
6	52	7131U124		•	•	•					
3	1.5	9-3/4	7131U474	•	•	•		•	•		
	2.25	14-1/4	7131U484	•	•	•	•	•	•	•	•
	3	18-1/2	7131U494	•	•	•	•	•	•	•	•
	3.75	22-3/4	7131U504	•	•	•	•	•	•	•	•
	4.5	27	7131U514	•	•	•	•	•	•	•	•
	6	35-1/4	7131U524		•	•	•	•	•	•	•
	7.5	43-3/4	7131U534		•	•	•	•	•	•	•
	9	52	7131U544			•	•	•	•	•	•
	10	57-1/2	7131U554				•	•	•	•	•
	12	68-1/2	7131U564				•	•	•	•	•

B Dimensions (Inches)	Catalog Number*	With Built-In Thermostat, NEMA 1 Terminal Box							
		Availability							
		1 Phase			3 Phase				
120V	208V	240V	480V	208V	240V	480V			
18-1/2	7131U284	•	•	•	•				
27	7131U294	•	•	•	•				
35-1/4	7131U304	•	•	•	•				
43-3/4	7131U314	•	•	•	•				
52	7131U324	•	•	•	•				
10	7131U394	•	•	•					
14-1/4	7131U014	•	•	•	•				
16-1/4	7131U404	•	•	•	•				
18-1/2	7131U414	•	•	•	•				
20-1/2	7131U424	•	•	•	•				
22-3/4	7131U054	•	•	•	•				
27	7131U434	•	•	•	•				
35-1/4	7131U444	•	•	•	•				
43-3/4	7131U454		•	•	•				
52	7131U464		•	•	•				
9-3/4	7131U574	•	•	•		•	•		
14-1/4	7131U584	•	•	•	•	•	•	•	•
18-1/2	7131U594	•	•	•	•	•	•	•	•
22-3/4	7131U604	•	•	•	•	•	•	•	•
27	7131U614	•	•	•	•	•	•	•	•
35-1/4	7131U624		•	•	•	•	•	•	•
43-3/4	7131U634		•	•	•	•	•	•	•
52	7131U644			•	•	•	•	•	•
57-1/2	7131U654				•	•	•	•	•
68-1/2	7131U664				•	•	•	•	•

Please specify volts, phase, terminal box rating and, if needed, thermostat range from options listed on page 17.

*UL Listing is available with thermostat built-in NEMA 1 Box only. For all other terminal box options, use 713N designation.



Pipe Thread Heaters

2-1/2" Pipe Thread Heaters

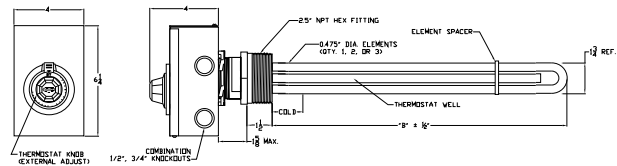
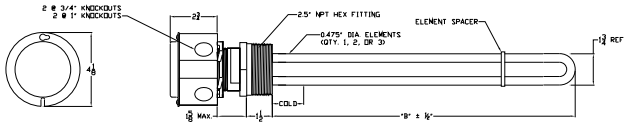

Water

304 SS Sheath, 304 SS Fitting

50 W/Sq. In.

Number of Elements	KW	Without Thermostat, NEMA 1 Terminal Box		Availability						
		B Dimensions (Inches)	Catalog Number	1 Phase			3 Phase			
				120V	208V	240V	480V	208V	240V	480V
3	3	8	7141U636	•	•	•	•	•	•	•
	4.5	11-1/2	7141U726	•	•	•	•	•	•	•
	6	14-3/4	7141U676		•	•	•	•	•	•
	7.5	18	7141U696		•	•	•	•	•	•
	9	21-1/2	7141U716			•	•	•	•	•
	12	28-1/4	7141U756				•	•	•	•
	15	35	7141U776					•	•	•
	18	41-1/2	7141U796						•	•
	20	46	7141U736							•

With Built-In Thermostat, NEMA 1 Terminal Box		Availability					
B Dimensions (Inches)	Catalog Number*	1 Phase			3 Phase		
		120V	208V	240V	480V	208V	240V
8	7141U746	•	•	•	•	•	•
11-1/2	7141U766	•	•	•	•	•	•
14-3/4	7141U786		•	•	•	•	•
18	7141U806		•	•	•	•	•
21-1/2	7141U816			•	•	•	•
28-1/4	7141U826				•	•	•
35	7141U836					•	•
41-1/2	7141U846						•
46	7141U856						•

1 and 2 element designs available. Consult factory.

Please specify volts, phase, terminal box rating and, if needed, thermostat range from options listed on page 16.

*UL Listing is available with thermostat built-in NEMA 1 Box only. For all other terminal box options, use 714N designation.

Water

Copper Sheath, 304SS Fitting

50 W/Sq. In.

Number of Elements	KW	Without Thermostat, NEMA 1 Terminal Box		Availability						
		B Dimensions (Inches)	Catalog Number	1 Phase			3 Phase			
				120V	208V	240V	480V	208V	240V	480V
3	3	8	7141U431	•	•	•	•	•	•	•
	4	10-1/4	7141U291	•	•	•	•	•	•	•
	4.5	11-1/2	7141U451	•	•	•	•	•	•	•
	5	12-1/2	7141U301		•	•	•	•	•	•
	6	14-3/4	7141U471		•	•	•	•	•	•
	7	17	7141U311		•	•	•	•	•	•
	7.5	18	7141U491		•	•	•	•	•	•
	8	19-1/4	7141U321		•	•	•	•	•	•
	9	21-1/2	7141U511			•	•	•	•	•
	10	23-3/4	7141U331				•	•	•	•
	12	28-1/4	7141U341					•	•	•
	15	35	7141U351						•	•
	18	41-1/2	7141U361							•
	20	46	7141U371							•

With Built-In Thermostat, NEMA 1 Terminal Box		Availability					
B Dimensions (Inches)	Catalog Number*	1 Phase			3 Phase		
		120V	208V	240V	480V	208V	240V
9-1/4	7141U381	•	•	•		•	•
11-1/2	7141U391	•	•	•	•	•	•
12-1/4	7141U401	•	•	•	•	•	•
13-3/4	7141U411		•	•	•	•	•
15-3/4	7141U421		•	•	•	•	•
18	7141U441		•	•	•	•	•
19-1/4	7141U461		•	•	•	•	•
20-1/4	7141U481		•	•	•	•	•
22-1/2	7141U501			•	•	•	•
24-3/4	7141U521				•	•	•
29	7141U531					•	•
36	7141U541						•
42-3/4	7141U551						•
47-1/4	7141U561						•

1 and 2 element designs available. Consult factory.

Please specify volts, phase, terminal box rating and, if needed, thermostat range from options listed on page 17.

*UL Listing is available with thermostat built-in NEMA 1 Box only. For all other terminal box options, use 714N designation.

Pipe Thread Heaters

2-1/2" Pipe Thread Heaters

Oil

Steel Sheath, Steel Fitting

20 W/Sq. In.

Number of Elements	KW	Without Thermostat, NEMA 1 Terminal Box								
		B Dimensions (Inches)	Catalog Number	Availability						
				1 Phase		3 Phase				
				120V	208V	240V	480V	208V	240V	480V
3	1.5	9-3/4	7141U084	•	•	•		•	•	
	2	12-7 ¹ / ₁₆	7141U094	•	•	•		•	•	
	2.5	15-1/4	7141U104	•	•	•	•	•	•	•
	3	18	7141U324	•	•	•	•	•	•	•
	4	23-5/8	7141U114	•	•	•	•	•	•	•
	4.5	26-1/2	7141U344	•	•	•	•	•	•	•
	5	29-1/4	7141U124		•	•	•	•	•	•
	6	35	7141U364		•	•	•	•	•	•
	7.5	43-1/4	7141U384		•	•	•	•	•	•
	9	51-3/4	7141U404			•	•	•	•	•
	10	57-1/8	7141U134				•	•	•	•
	12	68-1/2	7141U144					•	•	•

With Built-In Thermostat, NEMA 1 Terminal Box								
B Dimensions (Inches)	Catalog Number*	Availability						
		1 Phase		3 Phase				
		120V	208V	240V	480V	208V	240V	480V
9-3/4	7141U154	•	•	•		•	•	
12-7 ¹ / ₁₆	7141U164	•	•	•		•	•	
15-1/4	7141U174	•	•	•	•	•	•	•
18	7141U184	•	•	•	•	•	•	•
23-5/8	7141U194	•	•	•	•	•	•	•
26-1/2	7141U204	•	•	•	•	•	•	•
29-1/4	7141U214		•	•	•	•	•	•
35	7141U224		•	•	•	•	•	•
43-1/4	7141U234		•	•	•	•	•	•
51-3/4	7141U244			•	•	•	•	•
57-1/8	7141U254				•	•	•	•
68-1/2	7141U264					•	•	•

1 and 2 element designs available. Consult factory.

Please specify volts, phase, terminal box rating and, if needed, thermostat range from options listed on this page.

*UL Listing is available with thermostat built-in NEMA 1 Box only. For all other terminal box options, use 714N designation.

Heater Options

Liquidproof NEMA 4 Outlet Box (Without Built-In Thermostat)

- Cast box with threaded, gasketed cover and 1" NPT female threaded hubs for electrical connections. For applications where there is danger of moisture entering the outlet box.

Explosion Resistant Heater - Rated for Class I, Div. I, Groups B, C & D. Applications are available, see page 32.

Liquidproof NEMA 4 Outlet Box (With Built-In Thermostat) - Welded steel outlet box with enamel finish and gasketed cover. Pilot light is visible through lens cover. Two 1" NPT hubs provided for electrical connections. Stainless steel outlet box is available as an option.

Single-Pole, Single-Throw Thermostats - Standard on all single-phase heaters and all pilot duty applications. See Page 47 for selection criteria. If pilot light or an ON/OFF switch is required, specify double-pole single-throw thermostat.

Omit Outlet Box - For applications where heater terminals will be protected by field-furnished enclosures.

Special Sheath Materials - Incoloy 800, Inconel 600, Type 316 stainless steel and Monel 400 available.

Special Header Materials - Incoloy 800, Inconel 600 and Type 316 stainless steel headers available.

Vertical Mounting for 1-1/4", 2", and 2-1/2" Pipe Thread Heaters with Thermostat - Thermostat must be mounted vertically. Heaters with single-pole, single-throw thermostats can be mounted in any position without relocating the box.

Other Special Ratings - 2 & 2-1/2"

NPT pipe thread heaters available in any non stock voltage up to 600 volts. All sizes available with lower watt densities for special applications.

Longer Elements - Consult factory for length and wattage limits per element.

UL/CSA Approval - Available on all standard heaters listed.

Longer Element Cold Ends - Cold ends are 3/4" for copper, or 1-5/16" for stainless and steel. In vertically mounted heaters and other applications where the liquid will not completely cover the elements, immersion length should be increased by the length of additional cold end.



Flange Heaters

Construction Features

- Removable NEMA 1 outlet boxes provide free access to line terminals.
- Element spacers prevent hot spots.
- Permanent bus bars prevent loose connections.
- CSA approval available on most items.
- Raised face flanges insure leak-tight union with mating flange.
- Lifting rings afford ease of handling.
- Large diameter elements provide extra electrical insulation for better dielectric strength.

Field Wire and Knockout Sizing

Table II

Number of Three-Phase Circuits					Field Wire Gauge	Number Of Circuits (Three-Phase)	Maximum Outlet Box Temperature (°F)			
5	4	3	2	1			158	320	392	
Trade Size Conduit Required (Inches)							Wire Insulation Rating (°C)			
							90	200	250	
					Maximum Amps Per Three-Phase Circuit					
1-1/4	1	1	3/4	1/2	14*	1	12	18	19.1	
						2		14.4	15.2	
						3		12.6	13.3	
						4-5		9	9.5	
1-1/4	1	1	3/4	1/2	12*	1	16	22.5	26.4	
						2		18	21.1	
						3		15.7	18.5	
						4-5		—	11.2	13.2
1-1/2	1-1/2	1-1/4	1	3/4	10*	1	23.2	30	35.7	
						2		18.5	24	28.6
						3		16.2	21	25
						4-5		—	15	17.8
2	2	2	1-1/2	1	8	1	31.9	41.5	45.5	
						2		25.5	33.2	36.4
						3		22.3	29	31.9
						4-5		15.9	20.7	22.7
2-1/2	2	2	1-1/2	1-1/4	6	1	43.5	55	57.3	
						2		34.8	44	45.8
						3		30.4	38.5	40.1
						4-5		21.7	27.5	28.6
3	2-1/2	2-1/2	2	1-1/4	4	1	55.1	62.5	72.5	
						2		44	50	58
						3		38.5	43.7	50.7
						4-5		27.5	31.2	36.2
3	3	2-1/2	2	1-1/2	3	1	63.8	76	81.3	
						2		51	60.8	65
						3		44.6	53.2	56.9
						4-5		31.9	38	40.6
Consult Factory	3	2-1/2	2	1-1/2	2	1	75.4	85.5	93.5	
						2		60.3	68.4	74.8
						3		52.7	59.8	65.5
						4-5		37.7	42.7	46.7
Consult Factory	Consult Factory	3	2-1/2	2	1	1	87	98.5	105.3	
						2		69.6	78.8	84.2
						3		60.9	68.9	73.7
						4-5		43.5	—	—

Values per NEC 2005 Article 310.

Conduit sizing is based on largest wire insulation thickness for temperature ratings shown.

Consult factory for wire sizes above 1 gauge or if required amps per circuit is above listed values.

*Wire gauges 14, 12 and 10 are sized based on maximum fuse size per NEC Article 240-3.

Flange Heaters

Construction Features (continued)

Outlet Boxes - Removable NEMA 1 outlet boxes are furnished on heaters with 3" through 8" flanges, drawing up to 150 amps. A permanently mounted plate contains electrical knockouts.

On heaters with 10" and 12" flanges, or heaters drawing more than 150 amps, permanently attached NEMA 1 outlet boxes with threaded hubs are provided.

Element Spacers - Element spacers are fabricated from material similar to the element sheath and are normally perforated to allow for maximum fluid flow parallel to the elements. They prevent hot spots caused by elements touching while maintaining the size and rigidity of the heater bundle.

Spacers are provided on 24" maximum centers and are secured in such a manner as to allow elements to expand and contract freely.

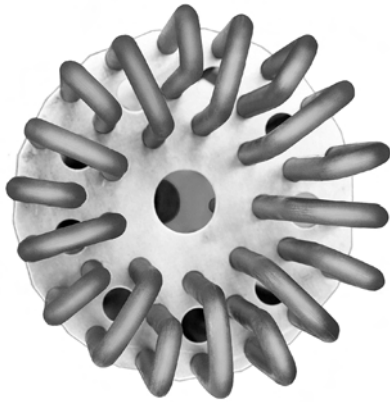

Flanges - Raised face flanges carry a nominal Class 150 rating and are made from forged steel or mill certified steel plate to ANSI standards. Raised face insures a leak-tight gasketed union with mating flange.

Electrical Connections - Pipe flange heaters are furnished with properly sized terminals and conduit openings to match the heater load, number of circuits and operating temperature. Table II shows the maximum amperage per circuit for various gauges of field wiring brought to heaters having one through five circuits. Note: The maximum conduit size is 3".

Unless otherwise specified, heaters are furnished with conduit openings and terminals suitable for a maximum outlet box temperature of 250° F and the number of circuits shown in the table. Heaters ordered with additional circuits, or for higher fluid temperatures, will be furnished with conduit openings and terminals to accommodate the wire gauges shown in Table II.

For three-phase conduits, amperage per circuit is calculated as follows:

$$\frac{\text{Total Heater KW} \times 1000}{\text{Line Voltage} \times \text{No. of Circuits} \times 1.73}$$

Occasionally low KW heaters operate from single-phase power. In this case, omit the 1.73 factor in the above formula.

When a heater has more than five circuits, or requires field wiring that will not fit into a single 3" conduit, multiple conduit openings will be furnished. For example, a heater with outlet box temperatures of 350° F with six circuits drawing 70 amps each would be furnished with two openings, each sized for 3" conduit. At 70 amps, 250° C insulated 1 gauge field wiring is required for three circuits per conduit.

Gasketing - A 1/16" thick gasket is furnished as standard with each heater. The gasket is sized to match the seating surface on the flange. Spirotallic gaskets are also available.

Flange Temperature/Pressure Ratings - Although pipe flanges have nominal ratings, the actual pressure that they will safely withstand is a function of temperature. Table III below shows pressure ratings per ANSI Standard B16.5.

Flange Pressure Ratings (PSI)

Table III

Maximum Fluid Temperature °F	Class 150 Steel Flange (Standard)	Class 300 Steel Flange	Class 150 Type 304 SS Flange
-20 to 100	285	740	275
200	260	675	235
300	260	655	205
400	200	635	180
500	170	600	170
600	140	550	140
650	125	535	125
700	110	535	110
750	95	505	95
800	80	410	80
850	65*	270*	65
900	50*	170*	50
950	35*	105*	35
1000	20*	50*	20

*These ratings are permissible, but not recommended. Type 304 stainless is preferred above 800° F.

Flange Heaters

Construction Features (continued)

Bus Bars - Stainless steel bus bars are permanently welded in place to eliminate field failures due to loose bus connections. Copper bus bars are used with lower temperature heaters and where amperage is high.



Large Diameter Elements - Elements measure .475" O.D., providing extra electrical insulation for superior dielectric strength. As a result, elements are suitable for line voltages up to 600 volts. At the same time, uniform heat transfer from coil to sheath is assured by compacting the insulation in high pressure rollers, then repressing all bends to insure insulation integrity in this critical area. Copper sheathed elements are silver soldered to the flange; all other materials are welded.

Unheated Lengths - It is imperative that the entire heated length of an element be submerged in liquid to prevent the sheath from overheating. Normally, copper, steel and stainless steel sheathed heaters have a 2" minimum cold end (unheated length). Incoloy sheathed heaters have a 5" minimum cold end.

Vertically mounted heaters require a longer cold end in applications where the liquid may not otherwise cover the elements.

Terminal Seals - Moisture-resistant epoxy seals are furnished as standard on all copper sheathed heaters operating in maximum fluid temperatures of 250° F.

Since steel, stainless steel and Incoloy sheathed heaters may operate at higher temperatures, standard units in these materials are furnished with mica terminal insulators and without epoxy seals.

When specified, and within temperature limits, epoxy seals are available with steel, stainless steel and Incoloy sheaths.

For applications requiring an absolute seal against moisture, ceramic-to-metal hermetic seals are available for temperatures up to 1000° F.

Lifting Rings - Lifting rings are provided on all heaters with flanges 4" and larger to facilitate handling.

Circuiting - All standard heaters are designed with electrical connections for a maximum outlet box temperature of 250° F with one electrical circuit for single stage operation unless two or more circuits are specified in the listing tables.

Additional circuits are available upon request.

Three-phase circuits are always balanced using a multiple of three elements per circuit.

Flange Heaters

Construction Features (continued)

Dimensions of Class 150 ANSI Flange Heaters

Nominal flange size (inches)	Flange diameter (inches)	Flange thickness (inches)	Bolt circle (inches)	Bolt hole diameter (inches)	Bolt diameter (inches)	Number of bolts
2	6	3/4	4-3/4	3/4	5/8	4
3	7-1/2	15/16	6	3/4	5/8	4
4	9	15/16	7-1/2	3/4	5/8	8
5	10	15/16	8-1/2	7/8	3/4	8
6	11	1	9-1/2	7/8	3/4	8
8	13-1/2	1-1/8	11-3/4	7/8	3/4	8
10	16	1-3/16	14-1/4	1	7/8	12
12	19	1-1/4	17	1	7/8	12
14	21	1-3/8	18-3/4	1-1/8	1	12
16	23-1/2	1-4/9	21-1/4	1-1/8	1	16
18	25	1-9/16	22-3/4	1-1/8	1-1/8	16

Dimensions of Class 300 ANSI Flange Heaters

Nominal flange size (inches)	Flange diameter (inches)	Flange thickness (inches)	Bolt circle (inches)	Bolt hole diameter (inches)	Bolt diameter (inches)	Number of bolts
2	6-1/2	7/8	5	3/4	5/8	8
3	8-1/4	1-1/8	6-5/8	7/8	3/4	8
4	10	1-1/4	7-7/8	7/8	3/4	8
5	11	1-3/8	9-1/4	7/8	3/4	8
6	12-1/2	1-7/16	10-5/8	7/8	3/4	12
8	15	1-5/8	13	1	7/8	12
10	17-1/2	1-7/8	15-1/4	1-1/8	1	16
12	20-1/2	2	17-3/4	1-1/4	1-1/8	16
14	23	2-1/8	20-1/4	1-1/4	1-1/8	20
16	25-1/2	2-1/4	22-1/5	1-3/8	1-1/4	20
18	28	2-3/8	24-3/4	1-3/8	1-1/4	24

Height of Terminal Boxes

Nominal flange size (inches)	Flange diameter (inches)	Flange thickness (inches)	Bolt circle (inches)	Bolt hole diameter (inches)	Bolt diameter (inches)	Number of bolts
2	4-3/8	8-1/2	4-3/8	8-1/2	6	9-1/2
3	4-3/8	9-3/4	5-1/4	9-1/2	6	10-1/2
4	4-3/8	9	5-1/4	8-1/4	6	9
5	5	9	5-1/4	8-1/4	6	9
6	5	9	5-1/4	8-1/4	6	9
8	6	10	5-1/4	8-1/4	10	10
10	8-1/4	8-1/4	8-1/4	8-1/4	10	10
12	8-1/4	8-1/4	8-1/4	8-1/4	Consult Factory	Consult Factory

Flange Heaters

Water Heaters

Copper Sheath, Steel Flange

50 W/Sq. In.

Flange Size (Inches)	Number of Elements	KW	NEMA 1 Terminal Box							
			B Dimensions (Inches)	Catalog Number	Availability					
					1 Phase			3 Phase		
208V	240V	480V	208V	240V	480V	208V	240V	480V		
3	3	4.5	12-3/4	721N0321	•	•	•	•	•	•
		6	16	721N0521	•	•	•	•	•	•
		7.5	19-1/2	721N0721	•	•	•	•	•	•
		9	22-3/4	721N0921	•	•	•	•	•	•
		12	29-1/2	721N1121	•	•	•	•	•	•
		15	36-1/4	721N1221	•	•	•	•	•	•
		18	43	721N1321	•	•	•	•	•	•
		21	49-1/2	721N1421	•	•	•	•	•	•
		24	56-1/4	721N1521	•	•	•	•	•	•
		30	69-3/4	721N1621	•	•	•	•	•	•
5	6	9	13	722N0321	•	•	•	•	•	•
		12	16-1/4	722N0521	•	•	•	•	•	•
		15	19-3/4	722N0721	•	•	•	•	•	•
		18	23	722N0921	•	•	•	•	•	•
		24	29-3/4	722N1121	•	•	•	•	•	•
		30	36-1/2	722N1221	• ²	• ²	•	•	•	•
		36	43-1/4	722N1321	• ²	• ²	•	•	•	•
		42	49-3/4	722N1421	• ²	• ²	•	•	•	•
		48	56-1/2	722N1521	• ²	• ²	•	• ²	•	•
		60	70	722N1721	•	•	• ²	•	•	•
5	9	18	16-1/4	722N2221	•	•	•	•	•	•
		24	20-3/4	722N2521	•	•	•	•	•	•
		30	25-1/4	722N2721	• ³	• ³	•	•	•	•
		36	29-3/4	722N2821	• ³	• ³	•	•	•	•
		45	36-1/2	722N2921	• ³	• ³	•	• ³	•	•
		54	43-1/4	722N3021	• ³	• ³	•	• ³	• ³	•
		63	49-3/4	722N3121	• ³	• ³	• ³	• ³	• ³	•
		72	56-1/2	722N3221	• ³	• ³	• ³	• ³	• ³	•
		90	70	722N3421	•	•	• ³	•	•	•
		6	12	24	16-1/4	723N0521	•	•	•	•
30	19-1/2			723N0721	• ²	• ²	•	•	•	•
36	22-3/4			723N0921	• ²	• ²	•	•	•	•
48	31			723N1121	• ³	• ²	•	• ²	•	•
60	36-1/4			723N1221	• ³	• ³	• ²	• ²	• ²	•
72	43			723N1321	• ⁴	• ³	• ²	• ²	• ²	•
84	49-3/4			723N1421	• ⁴	• ³	• ²	• ²	• ²	•
96	56-1/4			723N1521	• ⁴	• ⁴	• ²	• ⁴	• ²	•
108	63			723N1621	• ⁴	• ²	•	• ⁴	• ²	•
120	69-3/4			723N1721	•	•	• ³	•	•	• ²

•²= Superscript indicates number of circuits.

Please specify volts, phase, circuits, terminal box rating and, if needed, thermostat range from options listed on page 27.

ANSI Flanges are available in larger sizes through 26".

Flange Size (Inches)	Number of Elements	KW	NEMA 1 Terminal Box							
			B Dimensions (Inches)	Catalog Number	Availability					
					1 Phase			3 Phase		
208V	240V	480V	208V	240V	480V	208V	240V	480V		
6	15	40	20-3/4	723N2521	• ³	• ³	•	•	•	•
		50	25	723N2721	• ³	• ³	•	• ⁵	• ⁵	•
		60	29-1/2	723N2821	• ³	• ³	• ³	• ⁵	• ⁵	•
		75	36-1/4	723N2921	• ³	• ³	• ³	• ⁵	• ⁵	•
		90	43	723N3021	• ³	• ⁵	• ³	• ⁵	• ⁵	•
		120	56	723N3221	•	• ⁵	• ³	• ⁵	• ⁵	• ⁵
		135	63	723N3321	•	• ⁵	• ³	•	• ⁵	• ⁵
		150	69-3/4	723N3421	•	•	• ³	•	•	• ⁶
8	18	36	16	724N0721	• ²	• ²	•	•	•	•
		48	20-1/2	724N0821	• ²	• ²	•	• ²	•	•
		54	22-3/4	724N0921	• ³	• ²	•	• ²	• ²	•
		60	25	724N1021	• ³	• ³	• ²	• ²	• ²	•
		72	29-1/2	724N1121	• ³	• ³	• ²	• ²	• ²	•
		90	36-1/4	724N1221	• ⁶	• ⁶	• ²	• ³	• ²	•
		108	42-7/8	724N1321	• ⁶	• ⁶	• ²	• ³	• ³	• ²
		126	49-1/2	724N1421	• ⁶	• ⁶	• ³	• ³	• ³	• ²
		144	56-1/4	724N1521	• ⁶	• ⁶	• ³	• ⁶	• ³	• ²
		162	63	724N1621	•	• ⁶	• ³	•	• ⁶	• ²
180	69-3/4	724N1721	•	•	• ⁶	•	•	• ²		
8	27	72	20-1/2	724N2521	• ³	• ³	• ³	• ³	• ³	•
		90	25	724N2721	• ⁹	• ⁹	• ³	• ³	• ³	•
		108	29-1/2	724N2821	• ⁹	• ⁹	• ³	• ³	• ³	•
		135	36-1/4	724N2921	• ⁹	• ⁹	• ³	• ³	• ³	•
		162	43	724N3021	• ⁹	• ⁹	• ³	• ⁹	• ⁹	•
		189	49-1/2	724N3121	• ⁹	• ⁹	• ⁹	• ⁹	• ⁹	•
		216	56-1/4	724N3221	• ⁹	• ⁹	• ⁹	• ⁹	• ⁹	•
		243	63	724N3321	•	• ⁹	• ⁹	•	• ⁹	•
		270	69-3/4	724N3421	•	•	• ⁹	•	•	• ³
		10	36	72	16	725N0521	• ³	• ³	• ²	• ²
96	20-1/2			725N0721	• ⁴	• ⁴	• ³	• ³	• ²	•
120	25			725N1021	• ⁶	• ⁶	• ³	• ³	• ³	•
144	29-1/2			725N1121	• ⁶	• ⁶	• ³	• ⁴	• ³	• ²
180	36-1/4			725N1221	• ⁹	• ⁹	• ⁴	• ⁶	• ⁴	• ²
216	43			725N1321	• ⁹	• ⁹	• ⁴	• ⁶	• ⁶	• ³
252	49-1/2			725N1421	• ¹²	• ⁹	• ⁶	• ⁶	• ⁶	• ³
288	56-1/4			725N1521	• ¹²	• ¹²	• ⁶	• ¹²	• ⁶	• ³
324	63			725N1621	•	• ¹²	• ⁶	•	• ¹²	• ⁴
360	69-3/4			725N1721	•	•	• ⁹	•	•	• ⁴
12	48	72	12-1/2	726N0421	• ³	• ³	• ²	• ²	• ²	•
		96	16	726N0521	• ⁴	• ⁴	• ²	• ⁴	• ²	•
		120	19-1/4	726N0621	• ⁶	• ⁶	• ³	• ⁴	• ⁴	• ²
		144	22-3/4	726N0921	• ⁶	• ⁶	• ³	• ⁴	• ⁴	• ²
		192	29-1/4	726N1121	• ⁸	• ⁸	• ⁴	• ⁸	• ⁴	• ²
		240	36	726N1221	• ¹²	• ¹²	• ⁶	• ⁸	• ⁸	• ⁴
		288	42-3/4	726N1321	• ¹²	• ¹²	• ⁶	• ⁸	• ⁸	• ⁴
		336	49-1/2	726N1421	•	• ¹²	• ⁶	• ⁸	• ⁸	• ⁴
		384	56-1/4	726N1521	•	•	• ⁸	• ¹⁶	• ⁸	• ⁴
		432	63	726N1621	•	•	• ⁸	• ¹⁶	• ⁸	• ⁴
480	69-1/2	726N1721	•	•	• ¹²	•	•	• ⁸		

Flange Heaters

Water Heaters

Type 304 SS Sheath, Steel Flange

50 W/Sq. In.

Flange Size (Inches)	Number of Elements	KW	NEMA 1 Terminal Box							
			B Dimensions (Inches)	Catalog Number	Availability					
					1 Phase		3 Phase			
208V	240V	480V	208V	240V	480V					
3	3	4.5	12-1/4	721N0201	•	•	•	•	•	•
		6	15-3/4	721N0301	•	•	•	•	•	•
		7.5	19	721N0401	•	•	•	•	•	•
		9	22-1/2	721N0501	•	•	•	•	•	•
		12	29-1/4	721N0601	•	•	•	•	•	•
		15	35-1/4	721N0701	•	•	•	•	•	•
		18	42-1/2	721N0801	•	•	•	•	•	•
		24	56	721N0901	•	•	•	•	•	•
		30	69-1/4	721N1001			•			•
		5	6	9	12-1/2	722N0201	•	•	•	•
12	16			722N0301	•	•	•	•	•	•
15	19-1/4			722N0401	•	•	•	•	•	•
18	22-3/4			722N0501	•	•	•	•	•	•
24	29-1/4			722N0601	• ²	• ²	•	•	•	•
30	36			722N0701	• ²	• ²	•	•	•	•
36	42-3/4			722N0801	• ²	• ²	•	•	•	•
48	56-1/4			722N0901	• ³	• ³	•	• ²	•	•
60	69-1/2			722N1001			• ²			•
5	9			18	16	722N1101	•	•	•	•
		22.5	19-1/4	722N1201	•	•	•	•	•	•
		27	22-3/4	722N1301	• ³	•	•	•	•	•
		36	29-1/4	722N1401	• ³	• ³	•	•	•	•
		45	36	722N1501	• ³	• ³	•	• ³	•	•
		54	42-3/4	722N1601	• ³	• ³	•	• ³	• ³	•
		72	56-1/4	722N1701	• ³	• ³	• ³	• ³	• ³	•
6	12	24	15-3/4	723N0301	•	•	•	•	•	•
		30	19-1/4	723N0401	• ²	• ²	•	•	•	•
		36	22-1/2	723N0501	• ²	• ²	•	•	•	•
		48	29-1/4	723N0601	• ²	• ²	•	• ²	•	•
		60	36	723N0701	• ³	• ³	• ²	• ²	• ²	•
		72	42-3/4	723N0801	• ³	• ³	• ²	• ²	• ²	•
		96	56	723N0901	• ⁴	• ⁴	• ²	• ⁴	• ²	•
		120	69-1/2	723N1001			• ³			• ²

•²= Superscript indicates number of circuits.

Please specify volts, phase, circuits, terminal box rating and, if needed, thermostat range from options listed on page 27.

ANSI Flanges are available in larger sizes through 26".

Flange Size (Inches)	Number of Elements	KW	NEMA 1 Terminal Box									
			B Dimensions (Inches)	Catalog Number	Availability							
					1 Phase		3 Phase					
208V	240V	480V	208V	240V	480V							
6	15	30	15-3/4	723N1101	• ³	• ³	•	•	•	•		
		37.5	19-1/4	723N1201	• ³	• ³	•	•	•	•		
		45	22-1/2	723N1301	• ³	• ³	•	•	•	•		
		60	29-1/4	723N1401	• ³	• ³	• ³	• ⁵	•	•		
		75	36	723N1501	• ⁵	• ⁵	• ³	• ⁵	• ⁵	•		
		90	42-3/4	723N1601	• ⁵	• ⁵	• ³	• ⁵	• ⁵	•		
		120	56	723N1701			• ³	• ⁵	• ⁵	• ⁵		
		150	69-1/2	723N1801			• ³	• ⁵	• ⁵	• ⁵		
		8	18	36	15-3/4	724N0301	• ²	• ²	•	•	•	•
				45	19	724N0401	• ²	• ²	•	• ²	•	•
54	22-1/2			724N0501	• ³	• ³	•	• ²	• ²	•		
72	29-1/4			724N0601	• ³	• ³	• ²	• ²	• ²	•		
90	35-3/4			724N0701	• ⁶	• ⁶	• ²	• ³	• ²	•		
108	42-1/2			724N0801	• ⁶	• ⁶	• ²	• ³	• ³	• ²		
144	56			724N0901	• ⁶	• ⁶	• ³	• ⁶	• ³	• ²		
180	69-1/2			724N1001			• ⁶			• ²		
8	27			54	15-3/4	724N1101	• ³	• ³	•	• ³	• ³	•
		67.5	19	724N1201	• ³	• ³	• ³	• ³	• ³	•		
		81	22-1/2	724N1301	• ³	• ³	• ³	• ³	• ³	•		
		108	29-1/4	724N1401	• ⁹	• ⁹	• ³	• ³	• ³	• ³		
		135	35-3/4	724N1501	• ⁹	• ⁹	• ³	• ⁹	• ⁹	• ³		
		162	42-1/2	724N1601	• ⁹	• ⁹	• ³	• ⁹	• ⁹	• ³		
		216	56	724N1701	• ⁹	• ⁹	• ⁹	• ⁹	• ⁹	• ³		
		270	69-1/2	724N1801			• ⁹			• ³		
10	36	54	12-1/4	725N0201	• ³	• ³	•	• ²	• ²	•		
		72	15-3/4	725N0301	• ³	• ³	•	• ²	• ²	•		
		90	19	725N0401	• ⁴	• ⁴	•	• ³	• ²	•		
		108	22-1/2	725N0501	• ⁶	• ⁶	• ²	• ³	• ²	•		
		144	29-1/4	725N0601	• ⁶	• ⁶	• ²	• ⁴	• ³	• ²		
		180	35-3/4	725N0701	• ⁹	• ⁹	• ²	• ⁶	• ⁴	• ²		
		216	42-1/2	725N0801	• ⁹	• ⁹	• ³	• ⁶	• ⁶	• ³		
		288	56	725N0901	• ¹²	• ¹²	• ³	• ¹²	• ⁶	• ³		
		360	69-1/2	725N1001			• ⁴			• ⁴		
		12	48	72	12-1/4	726N0201	• ³	• ³	• ²	• ²	• ²	•
96	15-1/2			726N0301	• ⁴	• ⁴	• ²	• ⁴	• ²	•		
120	19			726N0401	• ⁶	• ⁶	• ³	• ⁴	• ⁴	• ²		
144	22-1/4			726N0501	• ⁶	• ⁶	• ³	• ⁴	• ⁴	• ²		
192	29			726N0601	• ⁸	• ⁸	• ⁴	• ⁸	• ⁴	• ²		
240	35-3/4			726N0701	• ¹²	• ¹²	• ⁶	• ⁸	• ⁸	• ⁴		
288	42-1/2			726N0801	• ¹²	• ¹²	• ⁶	• ⁸	• ⁸	• ⁴		
384	56			726N0901			• ⁸	• ¹²	• ⁸	• ⁴		
480	69-1/4			726N1001			• ¹²			• ⁸		

Flange Heaters

Water Heaters

Incoloy 800 Sheath, Steel Flange

50 W/Sq. In.

Flange Size (Inches)	Number of Elements	KW	NEMA 1 Terminal Box							
			B Dimensions (Inches)	Catalog Number	Availability					
					1 Phase			3 Phase		
					208V	240V	480V	208V	240V	480V
3	3	4.5	15-1/4	721N0281	•	•	•	•	•	•
		6	18-3/4	721N0381	•	•	•	•	•	•
		7.5	22	721N0481	•	•	•	•	•	•
		9	25-1/2	721N0581	•	•	•	•	•	•
		12	32-1/4	721N0681	•	•	•	•	•	•
		15	38-3/4	721N0781	•	•	•	•	•	•
		18	45-1/2	721N0881	•	•	•	•	•	•
		24	59	721N0981	•	•	•	•	•	•
5	6	9	15-1/2	722N0281	•	•	•	•	•	•
		12	19	722N0381	•	•	•	•	•	•
		15	22-1/4	722N0481	•	•	•	•	•	•
		18	25-3/4	722N0581	•	•	•	•	•	•
		24	32-1/4	722N0681	• ²	• ²	•	•	•	•
		30	39	722N0781	• ²	• ²	•	•	•	•
		36	45-3/4	722N0881	• ²	• ²	•	•	•	•
		48	59-1/4	722N0981	• ³	• ³	•	• ²	•	•
5	9	18	19	722N1181	•	•	•	•	•	•
		22.5	22-1/4	722N1281	•	•	•	•	•	•
		27	28-3/4	722N1381	• ³	•	•	•	•	•
		36	32-1/4	722N1481	• ³	• ³	•	•	•	•
		45	39	722N1581	• ³	• ³	•	• ³	•	•
		54	45-3/4	722N1681	• ³	• ³	•	• ³	• ³	•
6	12	24	18-3/4	723N0381	•	•	•	•	•	•
		30	22-1/4	723N0481	• ²	• ²	•	•	•	•
		36	25-1/2	723N0581	• ²	• ²	•	•	•	•
		48	32-1/4	723N0681	• ²	• ²	•	• ²	•	•
		60	39	723N0781	• ³	• ³	• ²	• ²	• ²	•
		72	45-3/4	723N0881	• ³	• ³	• ²	• ²	• ²	•
		96	59	723N0981	• ⁴	• ⁴	• ²	• ⁴	• ²	•
		120	72-1/2	723N1081			• ³			• ²

•²= Superscript indicates number of circuits.

Please specify volts, phase, circuits, terminal box rating and, if needed, thermostat range from options listed on page 27.

ANSI Flanges are available in larger sizes through 26".

Flange Size (Inches)	Number of Elements	KW	NEMA 1 Terminal Box							
			B Dimensions (Inches)	Catalog Number	Availability					
					1 Phase			3 Phase		
					208V	240V	480V	208V	240V	480V
6	15	30	18-3/4	723N1181	• ³	• ³	•	•	•	•
		37.5	22-1/4	723N1281	• ³	• ³	•	•	•	•
		45	25-1/2	723N1381	• ³	• ³	•	• ⁵	•	•
		60	32-1/4	723N1481	• ³	• ³	• ³	• ⁵	• ⁵	•
		75	39	723N1581	• ⁵	• ⁵	• ³	• ⁵	• ⁵	•
		90	45-3/4	723N1681	• ⁵	• ⁵	• ³	• ⁵	• ⁵	•
		120	59	723N1781			• ³	• ⁵	• ⁵	• ⁵
		150	72-1/2	723N1881			• ³			• ⁵
8	18	36	18-1/4	724N0381	• ²	• ²	•	•	•	•
		45	22	724N0481	• ²	• ²	•	•	•	•
		54	25-1/2	724N0581	• ³	• ³	•	• ²	• ²	•
		72	32-1/4	724N0681	• ³	• ³	• ²	• ²	• ²	•
		90	38-3/4	724N0781	• ⁶	• ⁶	• ²	• ³	• ²	•
		108	45-1/2	724N0881	• ⁶	• ⁶	• ²	• ³	• ³	• ²
		144	59	724N0981	• ⁶	• ⁶	• ³	• ⁶	• ³	• ²
8	27	54	18-1/4	724N1181	• ³	• ³	•	• ³	• ³	•
		67.5	22	724N1281	• ³	• ³	• ³	• ³	• ³	•
		81	25-1/2	724N1381	• ⁹	• ⁹	• ³	• ³	• ³	•
		108	32-1/4	724N1481	• ⁹	• ⁹	• ³	• ³	• ³	• ³
		135	38-3/4	724N1581	• ⁹	• ⁹	• ³	• ⁹	• ³	• ³
		162	45-1/2	724N1681	• ⁹	• ⁹	• ³	• ⁹	• ³	• ³
		216	59	724N1781	• ⁹	• ⁹	• ³	• ⁹	• ³	• ³
10	36	54	15-1/4	725N0281	• ³	• ³	•	• ²	• ²	•
		72	18-1/4	725N0381	• ³	• ³	•	• ²	• ²	•
		90	22	725N0481	• ⁴	• ⁴	•	• ²	• ²	•
		108	25-1/2	725N0581	• ⁶	• ⁶	• ²	• ³	• ³	• ²
		144	32-1/4	725N0681	• ⁶	• ⁶	• ²	• ⁴	• ³	• ²
		180	38-3/4	725N0781	• ⁹	• ⁹	• ²	• ⁶	• ⁴	• ²
		216	45-1/2	725N0881	• ⁹	• ⁹	• ³	• ⁶	• ⁶	• ³
		288	59	725N0981	• ¹²	• ¹²	• ³	• ¹²	• ⁶	• ³
12	48	72	15-1/4	726N0281	• ³	• ³	• ²	• ²	• ²	•
		96	18-1/2	726N0381	• ⁴	• ⁴	• ²	• ⁴	• ²	•
		120	22	726N0481	• ⁶	• ⁶	• ³	• ⁴	• ⁴	• ²
		144	25-1/4	726N0581	• ⁶	• ⁶	• ³	• ⁴	• ⁴	• ²
		192	32	726N0681	• ⁸	• ⁸	• ⁴	• ⁸	• ⁴	• ²
		240	38-1/4	726N0781	• ¹²	• ¹²	• ⁶	• ⁸	• ⁸	• ⁴
		288	45-1/2	726N0881	• ¹²	• ¹²	• ⁶	• ⁸	• ⁸	• ⁴
		384	59	726N0981			• ⁸	• ¹⁶	• ⁸	• ⁴
480	72-1/4	726N1081			• ¹²			• ⁸		

Flange Heaters

Oil Heaters

Steel Sheath, Steel Flange

20 W/Sq. In.

Flange Size (Inches)	Number of Elements	KW	NEMA 1 Terminal Box							
			B Dimensions (Inches)	Catalog Number	Availability					
					1 Phase			3 Phase		
208V	240V	480V	208V	240V	480V	208V	240V	480V		
3	3	1.5	10-1/4	721N0141	•	•	•	•	•	•
		3	19	721N0341	•	•	•	•	•	•
		4.5	27-1/2	721N0541	•	•	•	•	•	•
		6	35-3/4	721N0641	•	•	•	•	•	•
		7.5	44-1/4	721N0741	•	•	•	•	•	•
		9	52-1/4	721N0841	•	•	•	•	•	•
5	6	12	69-1/2	721N0941	•	•	•	•	•	•
		4.5	15	722N0241	•	•	•	•	•	•
		6	19-1/4	722N0341	•	•	•	•	•	•
		7.5	23-1/2	722N0441	•	•	•	•	•	•
		9	27-1/4	722N0541	•	•	•	•	•	•
		12	36	722N0641	•	•	•	•	•	•
5	9	15	44-1/2	722N0741	•	•	•	•	•	•
		18	52-1/4	722N0841	•	•	•	•	•	•
		24	69-1/2	722N0941	•	•	•	•	•	•
		9	19-1/4	722N1241	•	•	•	•	•	•
		13.5	27-1/4	722N1441	•	•	•	•	•	•
		18	36	722N1541	•	•	•	•	•	•
6	12	22.5	44-1/2	722N1641	•	•	•	•	•	•
		27	52-3/4	722N1741	• ³	•	•	•	•	•
		36	69-1/2	722N1841	• ³	• ³	•	•	•	•
		12	19-1/4	723N0341	•	•	•	•	•	•
		15	23-1/4	723N0441	•	•	•	•	•	•
		18	27-1/2	723N0541	•	•	•	•	•	•
6	12	24	36	723N0641	•	•	•	•	•	•
		30	44-1/4	723N0741	• ²	• ²	•	•	•	•
		36	52-5/8	723N0841	• ²	• ²	•	•	•	•
		48	69-1/2	723N0941	• ²	• ²	•	• ²	•	•

Flange Size (Inches)	Number of Elements	KW	NEMA 1 Terminal Box							
			B Dimensions (Inches)	Catalog Number	Availability					
					1 Phase			3 Phase		
208V	240V	480V	208V	240V	480V	208V	240V	480V		
6	15	15	19-1/4	723N1241	•	•	•	•	•	•
		30	36	723N1541	• ³	• ³	•	•	•	•
		37.5	44-1/4	723N1641	• ³	• ³	•	•	•	•
		45	52-3/4	723N1741	• ³	• ³	•	• ⁵	•	•
		60	69-1/2	723N1841	• ³	• ³	• ²	• ⁵	• ²	•
8	18	18	19	724N0341	•	•	•	•	•	•
		22.5	23-1/4	724N0441	•	•	•	•	•	•
		27	27-1/2	724N0541	• ²	•	•	•	•	•
		36	35-3/4	724N0641	• ²	• ²	•	•	•	•
		45	44-1/4	724N0741	• ²	• ²	•	• ²	•	•
		54	52-3/4	724N0841	• ³	• ²	•	• ²	• ²	•
8	27	72	69-1/2	724N0941	• ³	• ³	• ²	• ²	• ²	•
		27	19	724N1241	• ³	•	•	•	•	•
		40.5	27-1/2	724N1141	• ³	• ³	•	•	•	•
		54	35-1/2	724N1541	• ³	• ³	• ³	• ³	•	•
		67.5	44-1/4	724N1641	• ³	• ³	• ³	• ³	•	•
10	36	81	52-3/4	724N1741	• ³	• ³	• ³	• ³	•	•
		108	69-1/2	724N1841	• ³	• ³	• ³	• ³	• ³	• ³
		36	19	725N0341	• ²	• ²	•	•	•	•
		45	23-1/4	725N0441	• ²	• ²	•	• ²	•	•
		54	27-1/2	725N0541	• ³	• ²	•	• ²	• ²	•
		72	35-3/4	725N0641	• ³	• ³	• ²	• ²	• ²	•
12	48	90	44-1/4	725N0741	• ⁴	• ⁴	• ²	• ³	• ²	•
		108	52-3/4	725N0841	• ⁶	• ⁴	• ²	• ³	• ³	• ²
		144	69-1/2	725N0941	• ⁶	• ⁶	• ³	• ⁴	• ³	• ²
		48	19	726N0341	• ²	• ²	•	• ²	•	•
		60	23	726N0441	• ³	• ³	• ²	• ²	• ²	•
		72	27-1/4	726N0541	• ³	• ³	• ²	• ²	• ²	•
12	48	96	35-3/4	726N0641	• ⁴	• ⁴	• ²	• ⁴	• ²	•
		120	44	726N0741	• ⁴	• ⁶	• ³	• ⁴	• ⁴	• ²
		144	52-1/2	726N0841	• ⁶	• ⁶	• ³	• ⁴	• ⁴	• ²
		192	69-1/4	726N0941	• ⁸	• ⁸	• ⁴	• ⁸	• ⁴	• ²

Steel Sheath, Steel Flange

Flange Size (Inches)	Number of Elements	KW	NEMA 1 Terminal Box							
			B Dimensions (Inches)	Catalog Number	Availability					
					1 Phase			3 Phase		
208V	240V	480V	208V	240V	480V	208V	240V	480V		
3	3	3	30-1/4	721N4141	•	•	•	•	•	•
		4.5	44-1/4	721N4241	•	•	•	•	•	•
		6	58-1/4	721N4341	•	•	•	•	•	•
		7.5	72-1/4	721N4441	•	•	•	•	•	•
		9	86	721N4541	•	•	•	•	•	•
5	6	4.5	23-1/2	722N5141	•	•	•	•	•	•
		6	30-1/2	722N5241	•	•	•	•	•	•
		9	44-1/2	722N5341	•	•	•	•	•	•
		12	58-1/4	722N5441	•	•	•	•	•	•
		15	72-1/4	722N5541	•	•	•	•	•	•
6	12	18	86-1/4	722N5641	•	•	•	•	•	•
		9	23-1/2	723N6141	•	•	•	•	•	•
		12	30-1/4	723N6241	•	•	•	•	•	•
		18	44-1/4	723N6341	•	•	•	•	•	•
		24	58-1/2	723N6441	•	•	•	•	•	•
6	12	30	72-1/4	723N6541	• ²	• ²	•	•	•	•
		36	86-1/4	723N6641	• ²	• ²	•	•	•	•

•²= Superscript indicates number of circuits.
 Please specify volts, phase, circuits, terminal box rating and, if needed, thermostat range from options listed on page 27.
 ANSI Flanges are available in larger sizes through 26".

12 W/Sq. In.

Flange Size (Inches)	Number of Elements	KW	NEMA 1 Terminal Box							
			B Dimensions (Inches)	Catalog Number	Availability					
					1 Phase			3 Phase		
208V	240V	480V	208V	240V	480V	208V	240V	480V		
8	18	13.5	23-1/4	724N7141	•	•	•	•	•	•
		18	30-1/4	724N7241	•	•	•	•	•	•
		27	44-1/4	724N7341	• ²	•	•	•	•	•
		36	58-1/4	724N7441	• ²	• ²	•	•	•	•
		45	72-1/4	724N7541	• ²	• ²	•	• ²	•	•
10	36	54	86	724N7641	• ³	• ²	•	• ²	• ²	•
		27	23-1/4	725N8141	• ²	•	•	•	•	•
		36	30-1/4	725N8241	• ²	• ²	•	•	•	•
		54	44-1/4	725N8341	• ³	• ²	•	• ²	• ²	•
		72	58-1/4	725N8441	• ³	• ³	• ²	• ²	• ²	•
		90	72-1/2	725N8541	• ⁴	• ⁴	• ²	• ³	• ²	•
12	48	108	86	725N8641	• ⁶	• ⁴	• ²	• ³	• ³	• ²
		36	23-1/4	726N9141	• ²	• ²	•	•	•	•
		48	30	726N9241	• ²	• ²	•	• ²	•	•
		72	44	726N9341	• ³	• ³	• ²	• ²	• ²	•
		96	58	726N9441	• ⁴	• ⁴	• ²	• ⁴	• ²	•
		120	72	726N9541	• ⁶	• ⁶	• ³	• ⁴	• ⁴	• ²
144	86	726N9641	• ⁶	• ⁶	• ³	• ⁴	• ⁴	• ²		

Flange Heaters

Oil Heaters

Incoloy 800 Sheath, Steel Flange

20 W/Sq. In.

Flange Size (Inches)	Number of Elements	KW	NEMA 1 Terminal Box							
			B Dimensions (Inches)	Catalog Number	Availability					
					1 Phase			3 Phase		
					208V	240V	480V	208V	240V	480V
3	3	1.5	13-1/4	721N1181	•	•	•	•	•	•
		3	22	721N1281	•	•	•	•	•	•
		4.5	30-1/2	721N1381	•	•	•	•	•	•
		6	38-3/4	721N1481	•	•	•	•	•	•
		7.5	47-1/4	721N1581	•	•	•	•	•	•
		9	55-3/4	721N1681	•	•	•	•	•	•
		12	72-1/2	721N1781	•	•	•	•	•	•
5	6	4.5	18	722N1881	•	•	•	•	•	•
		6	22-1/4	722N1981	•	•	•	•	•	•
		7.5	26-1/2	722N2081	•	•	•	•	•	•
		9	30-3/4	722N2181	•	•	•	•	•	•
		12	39	722N2281	•	•	•	•	•	•
		15	47-1/2	722N2381	•	•	•	•	•	•
		18	55-3/4	722N2481	•	•	•	•	•	•
5	9	9	22-1/4	722N2681	•	•	•	•	•	•
		13.5	30-3/4	722N2781	•	•	•	•	•	•
		18	39	722N2881	•	•	•	•	•	•
		22.5	47-1/2	722N2981	•	•	•	•	•	•
		27	55-3/4	722N3081	• ³	•	•	•	•	•
6	12	12	22-1/4	723N1981	•	•	•	•	•	•
		15	26-1/4	723N2081	•	•	•	•	•	•
		18	30-1/2	723N2181	•	•	•	•	•	•
		24	39	723N2281	•	•	•	•	•	•
		30	47-1/2	723N2381	• ²	• ²	•	•	•	•
6	12	36	55-5/8	723N2481	• ²	• ²	•	•	•	•
		48	77-1/2	723N2581	• ²	• ²	•	• ²	•	•

Flange Size (Inches)	Number of Elements	KW	NEMA 1 Terminal Box							
			B Dimensions (Inches)	Catalog Number	Availability					
					1 Phase			3 Phase		
					208V	240V	480V	208V	240V	480V
6	15	15	22-1/4	723N2681	•	•	•	•	•	•
		30	39	723N2781	• ³	• ³	•	•	•	•
		37.5	47-1/4	723N2881	• ³	• ³	•	•	•	•
		45	55-3/4	723N2981	• ³	• ³	•	• ⁵	•	•
		60	72-1/2	723N3081	• ³	• ³	• ³	• ⁵	• ⁵	•
8	18	18	22	724N1981	•	•	•	•	•	•
		22.5	26-1/4	724N2081	•	•	•	•	•	•
		27	30-1/2	724N2181	• ²	•	•	•	•	•
		36	38-3/4	724N2281	• ²	• ²	•	•	•	•
		45	47-1/4	724N2381	• ²	• ²	•	• ²	•	•
		54	55-3/4	724N2481	• ³	• ²	•	• ²	• ²	•
8	27	72	72-1/2	724N2581	• ³	• ³	• ²	• ²	• ²	•
		27	22	724N2681	• ³	•	•	•	•	•
		40.5	30-1/2	724N2781	• ³	• ³	•	•	•	•
		54	38-1/2	724N2881	• ³	• ³	•	• ³	• ³	•
8	27	67.5	47-1/4	724N2981	• ³	• ³	• ³	• ³	• ³	•
		81	55-3/4	724N3081	• ³	• ³	• ³	• ³	• ³	•
		108	72-1/2	724N3181	• ⁹	• ⁹	• ³	• ³	• ³	• ³
		36	22	725N1181	• ²	• ²	•	•	•	•
10	36	45	26-1/4	725N1281	• ²	• ²	•	• ²	•	•
		54	30-1/2	725N1381	• ³	• ³	•	• ²	• ²	•
		72	38-3/4	725N1481	• ³	• ³	• ²	• ²	• ²	•
		90	47-1/4	725N1581	• ⁴	• ⁴	• ²	• ³	• ²	•
		108	55-3/4	725N1681	• ⁶	• ⁴	• ²	• ³	• ³	• ²
12	48	144	72-1/2	725N1781	• ⁶	• ⁶	• ³	• ⁴	• ³	• ²
		48	22	726N1181	• ²	• ²	•	• ²	•	•
		60	26	726N1281	• ³	• ³	• ²	• ²	• ²	•
		72	30-1/4	726N1381	• ³	• ³	• ²	• ²	• ²	•
		96	38-3/4	726N1481	• ⁴	• ⁴	• ²	• ⁴	• ²	•
		120	47	726N1581	• ⁶	• ⁶	• ³	• ⁴	• ⁴	• ²
		144	55-1/2	726N1681	• ⁶	• ⁶	• ³	• ⁴	• ⁴	• ²
		192	72-1/4	726N1781	• ⁸	• ⁸	• ⁴	• ⁸	• ⁴	• ²

Incoloy 800 Sheath, Steel Flange

12 W/Sq. In.

Flange Size (Inches)	Number of Elements	KW	NEMA 1 Terminal Box							
			B Dimensions (Inches)	Catalog Number	Availability					
					1 Phase			3 Phase		
					208V	240V	480V	208V	240V	480V
3	3	3	33-1/4	721N1881	•	•	•	•	•	•
		6	61-1/4	721N1981	•	•	•	•	•	•
		9	89-1/4	721N2081	•	•	•	•	•	•
5	6	6	33-1/4	722N3281	•	•	•	•	•	•
		12	61-1/4	722N3381	•	•	•	•	•	•
		18	89-1/4	722N3481	•	•	•	•	•	•
6	12	12	33-1/4	723N3181	•	•	•	•	•	•
		24	61-1/4	723N3281	•	•	•	•	•	•
		36	89-1/4	723N3381	• ²	• ²	•	•	•	•

Flange Size (Inches)	Number of Elements	KW	NEMA 1 Terminal Box							
			B Dimensions (Inches)	Catalog Number	Availability					
					1 Phase			3 Phase		
					208V	240V	480V	208V	240V	480V
8	18	18	33-1/4	724N3281	•	•	•	•	•	•
		36	61-1/4	724N3381	• ²	• ²	•	•	•	•
		54	89-1/4	724N3481	• ³	• ²	•	• ²	• ²	•
10	36	36	33-1/4	725N1881	• ²	• ²	•	•	•	•
		72	61-1/4	725N1981	• ³	• ³	• ²	• ²	• ²	•
		108	89-1/4	725N2081	• ⁶	• ⁴	• ²	• ³	• ³	• ²
12	48	48	33-1/4	726N1881	• ²	• ²	•	• ²	•	•
		96	61-1/4	726N1981	• ⁴	• ⁴	• ²	• ⁴	• ²	•
		144	89-1/4	726N2081	• ⁶	• ⁶	• ³	• ⁴	• ⁴	• ²

•²= Superscript indicates number of circuits.
 Please specify volts, phase, circuits, terminal box rating and, if needed, thermostat range from options listed on page 27.
 ANSI Flanges are available in larger sizes through 26".

Heater Options

Built-In Thermostat - For fluid temperature control or high limit control. Available in NEMA 1 or liquidproof boxes. See page 21 for outlet box dimensions. Thermostat suitable for pilot duty operation only.

Specify temperature range:

0-100° F, 40-120° F, 60-250° F or 150-550° F

Pilot duty rating:

125 VA up to 240 Volts

Integral Thermostat Well - To protect and locate the bulb of a remotely mounted thermostat. Specify well length below flange and inside diameter if the thermostat is supplied by others.

Thermocouple Attached to Sheath - To monitor or limit the sheath temperature. Thermocouple is field-connected to control or to indicating device through jacks furnished in the outlet box. Type K Chromel-Alumel thermocouples with 316 stainless steel sheath, suitable for 1500° F maximum, are standard. Thermocouple is attached to an element in the first circuit near the U-bend unless an alternate location is specified.

Liquidproof/Explosion-Resistant Outlet Boxes - Steel boxes with threaded or bolted cover and female threaded hubs for electrical connections. For applications where there is danger of moisture entering the outlet box or for hazardous locations classified by the National Electrical Code. Consult factory for other types of hazard.

Hermetic Seals - For applications where an absolute moisture seal is required. Each element is fitted with ceramic-to-metal hermetic seals, which are airtight and impervious to outside influences. Seals are designed for terminal temperatures up to 1000° F.

Epoxy Seals - For moisture resistance where the fluid temperature does not exceed 250° F. Each element is sealed with epoxy as a barrier against moisture entering the element. Furnished as standard on copper-sheathed heaters.

RTV Seals - For moisture resistance where the fluid temperature does not exceed 400° F.

ASME partial stamp - Please provide design temperature, pressure and corrosion allowance.

Low flow spacers - For applications inside vessels where the pressure drop is critical.

Class 150 Stainless Steel Flanges - Type 304 stainless steel flanges are available where steel flanges may corrode and for fluid temperatures above 800° F. Stainless steel, Incoloy or Inconel elements are welded to the flange; copper elements are silver soldered. See page 19 for pressure/temperature ratings. Consult factory for higher pressure ratings.

Class 300 Steel Flanges - For use where pressure and/or temperature exceed the ratings of standard Class 150 flanges. See Table III for pressure/temperature ratings. Consult factory for steel flanges rated over Class 300, flanges rated Class 600, 900 and 1200 are available with extended lead times.

Larger Flanges - For added KW capacity, or to reduce pressure drop through the heater, larger flanges are available. Standard ANSI flanges available up through 26".

Special Flange Materials - Type 316 stainless steel, Incoloy 800, Inconel 600 and Monel 400 flanges are available with elements of matching sheath material for applications where all wetted surfaces are subject to the same corrosion requirements.

Spirallic Gaskets - Spiral wound Type 304 stainless steel gaskets recommended for extremes in joint relaxation, temperature or pressure cycling, shock or vibration.

Insulated Flange - Ceramic wool insulation 3" thick is used to reduce heat transfer from the fluid into the terminal box. Recommended for fluid temperatures over 500° F where the fluid temperature exceeds the field wiring insulation rating by more than 50° F, and for dual-purpose heating/cooling applications to prevent condensation in the terminal box during the cooling cycle.

Longer Element Cold Ends - Standard cold ends, 2" for copper, stainless and steel; 5" for Incoloy. In vertically mounted heaters and other applications where the liquid will not completely cover the elements, immersion length should be increased by the length of additional cold end.

Longer Elements - Immersion lengths up to 192" available for applications requiring lower watt densities or heat distribution throughout a long vessel.

Special Bending Configurations - For unusual tank designs or to keep elements covered at all times. For example, elements are normally curved or bent for lube oil reservoirs on shipboard to assure coverage as the ship rolls.



Flange Heaters

Heater Options (continued)

Special Sheath Material - For compatibility with fluid composition and fluid temperature. See Table I for material recommendations. Monel 400, Inconel 600 and Type 316 stainless steel are available.

Iron Content - In critical processes where no trace of iron can be tolerated, stainless steel heaters can be electropolished before installation.

Additional Circuits - For staged control of heater load. Standard number of heater stages shown in listing tables. Additional stages available consistent with number of elements. (Multiple of three elements required for three-phase circuits.)

Special Ratings - Non-standard KW ratings and special watt densities, required for certain fluids, are available.

Agency Approval - Most pipe flange heaters listed have been approved by CSA (Canadian Standards Association) under File No. LR11895-35. Ratings available up to 600 volts.

Explosion-proof pipe flange heaters have been approved by FM (Factory Mutual), CSA and L.C.I.E. (French Approval Agency) for use in Class I; Divisions 1, 2; Groups B, C, D hazardous locations. These explosion-proof immersion heater approvals include testing to the requirements of European CENELEC Standards EN50014 and EN50018. Consult factory for more information.

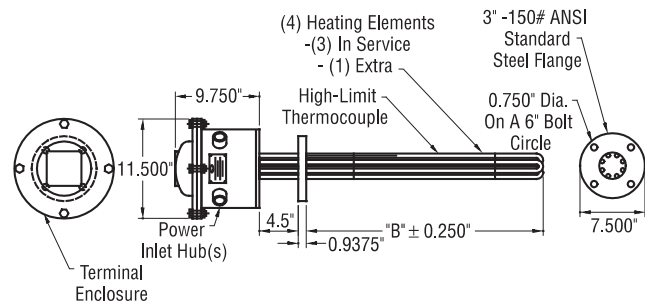

Compliance with Military Specifications - Heaters are available to meet a variety of military specifications. For example, for heating lubricating oil on shipboard, we furnish heaters per MIL-H-24299 with hermetic seals and liquidproof outlet boxes, tested per the specification. For water purification, we have furnished heaters per MIL-H-22577C. For heating hydraulic fluid, we have furnished heaters per MIL-S-901 and MIL-STD-167 covering special shock and vibration requirements.

High Temperature Construction - When the outlet box temperature exceeds 250° F, mica terminal insulators are furnished, and properly sized lugs and conduit openings for incoming wiring are provided. Above 500° F an extended terminal box is standard.

Over-the-Side Heaters

Construction Features

INDEECO Over-the-Side heaters are designed to provide the maximum in application flexibility and to minimize installation cost. They are ideal for jobs where easy installation and quick replacement or cleaning must be accomplished without emptying the tank.



Sludge Leg Spacers - To prevent burnouts from spot overheating and to keep elements out of sludge that normally collects in the bottom of the tank. Standard legs are 1-1/2" high; lengths up to 4" are available at no extra charge.

Reinforced Risers - To strengthen the joint between the riser and element junction box. Gussets are welded or silver soldered to the box and riser to provide this reinforcement.

Extension Arm - To place outlet box 6" away from riser and process tank, preventing damage to electrical connections due to evaporation. Longer arms are available at a nominal additional charge.

Liquidproof Outlet Box - Protects electrical connections from wash downs, splashing and dripping. Standard on all heaters.

Joints - Heaters have welded joints, pressure tested before assembly.

Operating Temperatures - Standard heaters are designed for a maximum operating temperature of 250° F. Contact factory for higher temperature applications.

Heater Options

A wide range of custom units have been designed. Please contact the factory for more information on any of the following options.

Special Sheath Materials - 316 stainless steel, Incoloy 800, Monel 400 and Inconel 600 are available.

Voltage	Capacity in KW	
	Single Phase	Three Phase
120	3.6	—
208	6.2	10.8
240	7.2	12.4
277	8.3	—
480	4.8	—

Built-In Thermostat - Built-in automatic temperature control over ranges of either 0–100° F, 40–120° F, or 60–250° F (please specify range on order). The thermostat comes complete with integral ON/OFF switch, pilot light and internal adjusting knob. It is a two-pole device capable of carrying the following KW loads:

Special Sludge Legs - For applications where sludge or sediment at the bottom of the tank may be more than 1-1/2" deep.

Special Riser Height - For heaters installed in tanks that are more than 30" deep. Risers above 96" should use a split coupling to facilitate installation and shipping.

Vertical Mounting - For installations where a horizontal configuration would interfere with workflow through the tank or where servicing a horizontal heater is impractical.

Fluid level must be maintained above the element junction box.

High Temperature Construction - Standard heaters are designed for 250° F operating maximum.

Curved Elements - To fit into a round tank. Elements can be curved to diameters of 16" and 20".

Low Water Cut-off Mounting Brackets - Can be added for use with the INDEECO panel for cooling tower freeze protection.

Removable Terminal Box - INDEECO externally threads a one-inch schedule 40 pipe and mounts a cast NEMA 4 terminal box to the riser.



Over-the-Side Heaters

Water Heaters

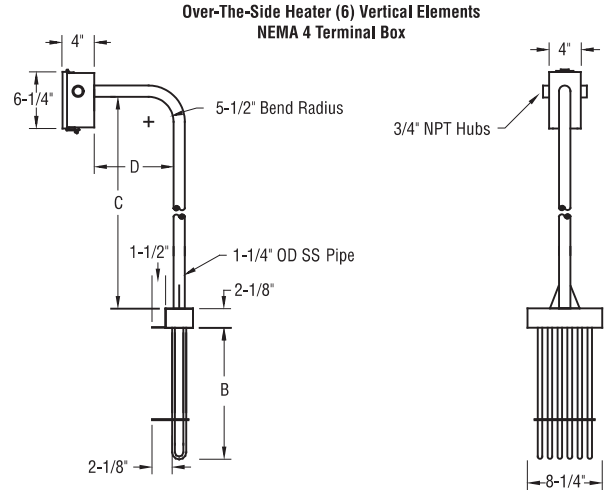
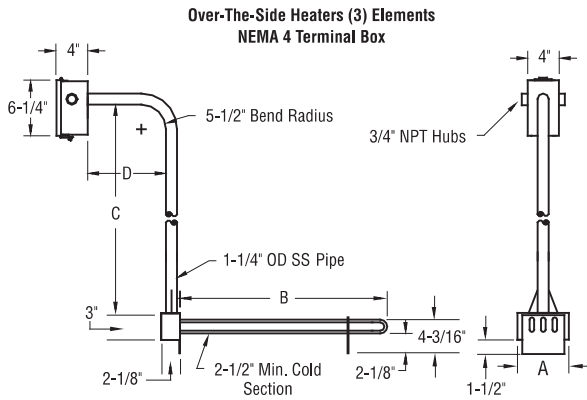

304 SS Sheath, 304 SS Fitting

A Dim. (Inches)	Number of Elements	KW	NEMA 4 Terminal Box									
			B Dim. (Inches)	Catalog Number	Availability							
					1 Phase			3 Phase				
					120V	208V	240V	480V	208V	240V	480V	
3-1/4	1	1.5	13-1/2	741N015	•	•	•	•	•	•	•	•
		2	16-3/4	741N025	•	•	•	•	•	•	•	•
		2.5	20	741N035	•	•	•	•	•	•	•	•
		3	23-1/2	741N045	•	•	•	•	•	•	•	•
		4	30-1/4	741N055	•	•	•	•	•	•	•	•
		5	36-3/4	741N065	•	•	•	•	•	•	•	•
		6	43-1/2	741N075	•	•	•	•	•	•	•	•
		8	57	741N085	•	•	•	•	•	•	•	•
		10	70-1/4	741N095	•	•	•	•	•	•	•	•
		4-3/4	2	2	10	742N105	•	•	•	•	•	•
3	13-1/2			742N115	•	•	•	•	•	•	•	•
4	16-3/4			742N125	•	•	•	•	•	•	•	•
5	20			742N135	•	•	•	•	•	•	•	•
6	23-1/2			742N145	•	•	•	•	•	•	•	•
8	30-1/4			742N155	•	•	•	•	•	•	•	•
10	36-3/4			742N165	•	•	•	•	•	•	•	•
12	43-1/2			742N175	•	•	•	•	•	•	•	•
5-3/4	3	3	10	743N185	•	•	•	•	•	•	•	•
		4.5	13-1/2	743N195	•	•	•	•	•	•	•	•
		6	16-3/4	743N205	•	•	•	•	•	•	•	•
		7.5	20	743N215	•	•	•	•	•	•	•	•
		9	23-1/2	743N225	•	•	•	•	•	•	•	•
		12	30-1/4	743N235	•	•	•	•	•	•	•	•
		15	36-3/4	743N245	•	•	•	•	•	•	•	•
		18	43-1/2	743N265	•	•	•	•	•	•	•	•
		24	57	743N275	•	•	•	•	•	•	•	•
		30	70-1/4	743N285	•	•	•	•	•	•	•	•

•²= Superscript indicates number of circuits.

Please specify volts, phase, circuits, terminal box rating and, if needed, thermostat range from options listed on page 26.

50 W/Sq. In.

A Dim. (Inches)	Number of Elements	KW	NEMA 4 Terminal Box								
			B Dim. (Inches)	Catalog Number	Availability						
					1 Phase			3 Phase			
					120V	208V	240V	480V	208V	240V	480V
8-1/4	6	9	13-1/2	744N235	• ²	•	•	•	•	•	•
		12	16-3/4	744N245	• ³	• ²	•	•	•	•	•
		15	20	744N255	• ³	• ²	• ²	•	•	•	•
		18	23-1/2	744N265	•	• ²	• ²	•	•	•	•
		24	30-1/4	744N275	•	• ³	• ³	•	• ²	• ²	•
		30	36-3/4	744N285	•	•	• ³	• ²	• ²	• ²	•
		36	43-1/2	744N295	•	•	•	• ²	•	• ²	•
		48	57	744N305	•	•	•	• ³	•	•	• ²
		60	70-1/4	744N315	•	•	•	•	• ³	•	• ²
		11-1/4	9	18	16-3/4	745N325	•	• ³	• ³	•	•
27	23-1/2			745N335	•	• ³	• ³	•	• ³	• ³	•
36	30-1/4			745N345	•	•	• ³	• ³	• ³	• ³	•
45	36-3/4			745N355	•	•	•	• ³	•	• ³	• ³
54	43-1/2			745N365	•	•	•	•	• ³	•	• ³
72	57			745N375	•	•	•	•	•	•	• ³
90	70-1/4			745N385	•	•	•	•	•	•	•
14-1/4	12			24	16-3/4	746N395	•	• ³	• ³	•	• ²
		30	20	746N405	•	•	• ³	• ²	• ²	• ²	•
		36	23-1/2	746N415	•	•	•	• ²	•	• ²	•
		48	30-1/4	746N425	•	•	•	•	• ³	•	• ²
		60	36-3/4	746N435	•	•	•	•	•	• ³	• ²
		72	43-1/2	746N445	•	•	•	•	•	• ³	• ²

Over-the-Side Heaters

Oil Heaters

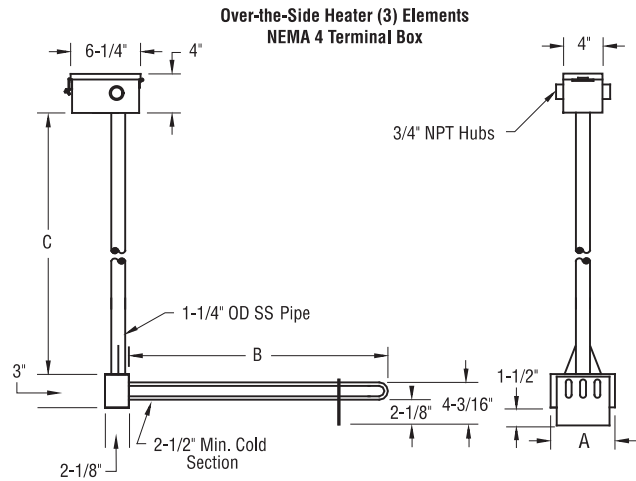
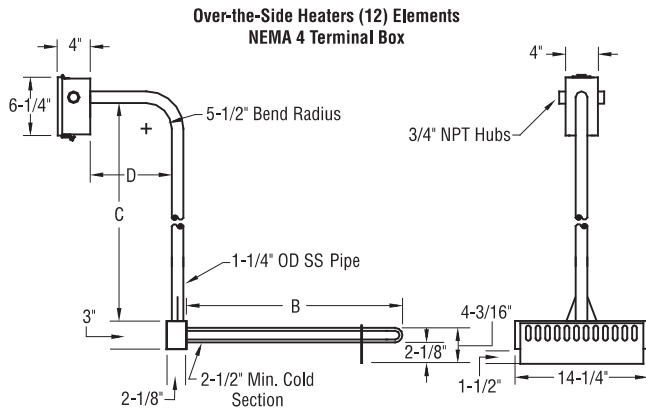

Steel Sheath, Steel Fitting

20 W/Sq. In.

A Dim. (Inches)	Number of Elements	KW	NEMA 4 Terminal Box								
			B Dim. (Inches)	Catalog Number	Availability						
					1 Phase			3 Phase			
120V	208V	240V	480V	208V	240V	480V					
3-1/4	1	.5	11-3/4	741N013	•	•	•				
		.75	16	741N023	•	•	•	•			
		1	20	741N033	•	•	•	•			
		1.25	24-1/4	741N043	•	•	•	•			
		1.5	28-1/2	741N053	•	•	•	•			
		2	36-3/4	741N063	•	•	•	•			
		2.5	45-1/4	741N073	•	•	•	•			
		3	53-3/4	741N083	•	•	•	•			
4-3/4	2	4	70-1/2	741N093	•	•	•	•			
		1.5	16	742N103	•	•	•	•			
		2	20	742N113	•	•	•	•			
		2.5	24-1/4	742N123	•	•	•	•			
		3	28-1/2	742N133	•	•	•	•			
		4	36-3/4	742N143	•	•	•	•			
		5	45-1/4	742N153	•	•	•	•			
		6	53-3/4	742N163	•	•	•	•			
5-3/4	3	8	70-1/2	742N173	•	•	•	•			
		1.5	11-3/4	743N183	•	•	•	•	•	•	•
		3	20	743N193	•	•	•	•	•	•	•
		4.5	28-1/2	743N203	•	•	•	•	•	•	•
		6	36-3/4	743N213	•	•	•	•	•	•	•
		7.5	45-1/4	743N223	• ³	•	•	•	•	•	•
		9	53-3/4	743N233	• ³	•	•	•	•	•	•
		12	70-1/2	743N243	• ³	•	•	•	•	•	•

A Dim. (Inches)	Number of Elements	KW	NEMA 4 Terminal Box								
			B Dim. (Inches)	Catalog Number	Availability						
					1 Phase			3 Phase			
120V	208V	240V	480V	208V	240V	480V					
8-1/4	6	6	20	744N253	•	•	•	•	•	•	•
		7.5	24-1/4	744N263	• ²	•	•	•	•	•	•
		9	28-1/2	744N273	• ²	•	•	•	•	•	•
		12	36-3/4	744N283	• ³	• ²	•	•	•	•	•
		15	45-1/4	744N293	• ³	• ²	• ²	•	•	•	•
		18	53-3/4	744N303	•	• ²	• ²	•	•	•	•
		24	70-1/2	744N313	•	• ³	• ³	•	• ²	• ²	•
		11-1/4	9	9	20	745N323	• ³	•	•	•	•
13.5	28-1/2			745N333	• ³	•	•	•	•	•	•
18	36-3/4			745N343	•	• ³	• ³	•	•	•	•
22.5	45-1/4			745N353	•	• ³	• ³	•	• ³	• ³	•
27	53-3/4			745N363	•	• ³	• ³	• ³	• ³	• ³	• ³
14-1/4	12	36	70-1/2	745N373	•	•	• ³	• ³	• ³	• ³	•
		12	20	746N383	• ³	• ²	•	•	•	•	•
		15	24-1/4	746N393	• ³	• ²	• ²	•	•	•	•
		18	28-1/2	746N403	•	• ²	• ²	•	•	•	•
		24	36-3/4	746N413	•	• ³	• ³	•	• ²	• ²	•
		30	45-1/4	746N423	•	•	• ³	• ²	• ²	• ²	•
		36	53-3/4	746N433	•	•	• ²	• ²	• ²	•	•
		48	70-1/2	746N443	•	•	•	• ³	•	• ²	•

•²= Superscript indicates number of circuits.

Please specify volts, phase, circuits, terminal box rating and, if needed, thermostat range from options listed on page 26.

CSA Listed Explosion-proof Heaters

Construction Features



INDEECO explosion-proof pipe thread mounted immersion heaters are CSA approved, File LR11895-74, for use in hazardous areas classified as Class I, Division 1, Groups B, C and D; and Class II, Division 1, Groups E, F and G.

These heaters are available in 2" NPT and 2-1/2" NPT construction. The fittings and element sheath(s) are 304 stainless steel and suitable for NEMA 3 and corrosive environments. A limited offering of 1-1/4" NPT heaters are available subject to restrictions on element count, well size and thermostat range. Consult the factory for additional information.



The end user is responsible for installation. The installation must include a high temperature limit and, if a tank application, a low liquid level control. The INDEECO thermostat, if specified, is for process control of the application.

For details on particular hazardous environments having potential for explosion, refer to Articles 500–516 of the National Electrical Code and/or Section 18 of the Canadian Electrical Code, Part 1.

These heaters are designed to be permanently mounted in a horizontal position above the anticipated sludge level. These heaters are approved for operation in a maximum ambient temperature of 40° C, 104° F.

Selection criteria include determining KW requirements and sheath watt density with an additional calculation of the temperature rating (T rating) **as shown on the next page**. INDEECO must know the fluid heated, which will appear on the nameplate, illustrated below.

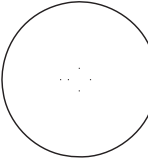
Construction features include .475" diameter compacted tubular element(s), repressed U-bends, nested third element with spacer for structural strength and either 0–100° F, 40–120° F or 60–250° F process thermostat.

	 Class I, Div.1, Groups B,C,&D Class II, Div.1, Groups E,F,&G	
	St. Louis, MO · USA	
Catalog # <input type="text"/>	KW <input type="text"/> Volts <input type="text"/> Phase <input type="text"/> 50/60 Hz, Temp. Code <input type="text"/>	
Process Temp. <input type="text"/> °F, <input type="text"/> °C, MWP [1655kPa (240psi)]		
Approved high temp. and level controls must be provided for safe operation. see instructions 71–2175–83		
For horizontal mounting in <input type="text"/> only.		
		N131-106

CSA Listed Explosion-proof Heaters

Temperature Code Calculations

This figure shows the relationship of the process temperature to the temperature identification code number, heater hot spot temperature, and the heater hot spot temperature for typical installations. Each installation should be checked and tested to determine actual hot spot temperatures.

1. Find the maximum process temperature on the "Y" axis, such as 250° F.
2. Make a line straight across until it crosses the maximum process temperature line (the top line), then make a line straight down from this point to the table below the graph.
3. For a 250° F process temperature, this line falls between Temperature Identification Numbers T5 and T4A. Since it is above T5, T4A is the lowest identification number you could use for this process.
4. Where this line crosses the heater hot spot temperature line (the bottom line), draw a straight line back to the "Y" axis to estimate the heater hot spot temperature. For this 250° F process example, it would be about 210° F.

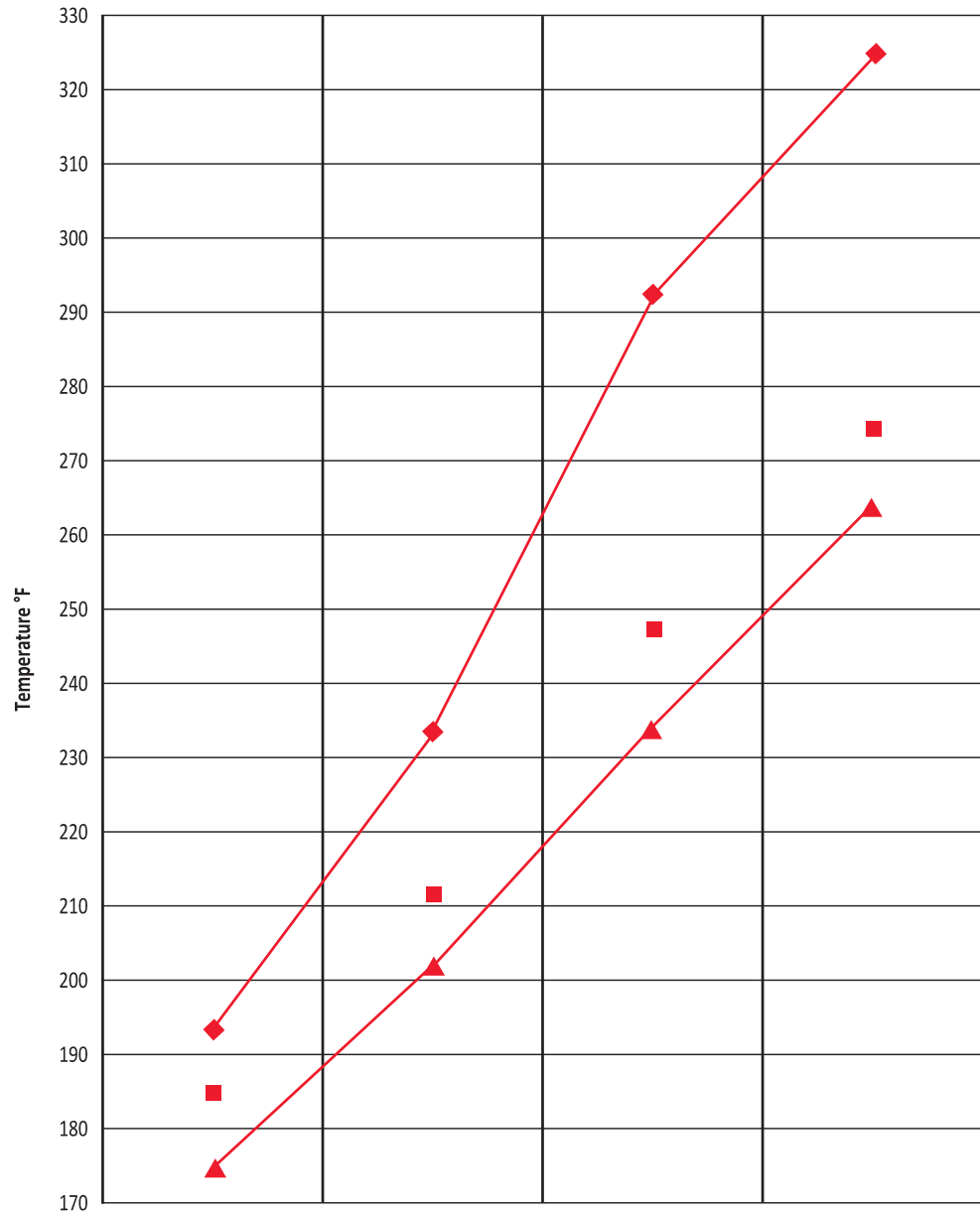

Temperature Identification Number	T6	T5	T4A	T4
◆ Maximum Process Temp., °F	193	233	292	324
■ Maximum Code Temp., °F	185	212	248	275
▲ Heater Hot Spot Temp., °F	175	202	234	264

CSA Listed Explosion-proof Heaters

Water Heaters

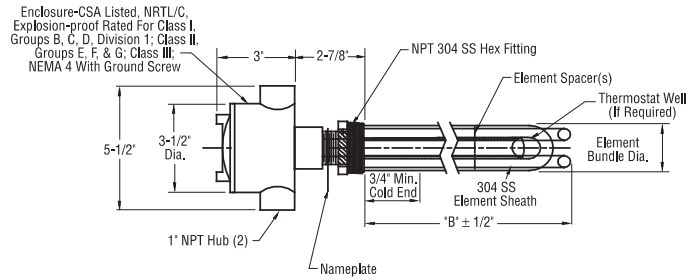
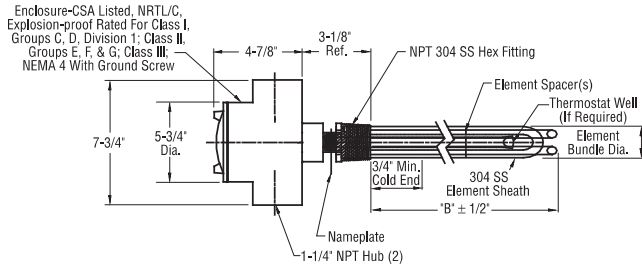

304 SS Sheath, 304 SS Fitting

50 W/Sq. In.

Number of Elements	KW	Without Thermostat		Availability						
		B Dimensions (Inches)	Catalog Number	Availability						
				1 Phase		3 Phase				
120V	208V	240V	480V	208V	240V	480V				
1	1	11-1/2	713F2563	•	•	•				
	1.5	14-3/4	713F2663	•	•	•	•			
	2	18-1/4	713F2763	•	•	•	•			
	2.5	21-1/2	713F2863	•	•	•	•			
	3	24-3/4	713F2963	•	•	•	•			
	4	31-1/2	713F3063	•	•	•	•			
	5	38-1/4	713F3163	•	•	•				
	6	45	713F3263	•	•	•				
2	2	11-1/2	713F3363	•	•	•	•			
	2.5	13	713F3463	•	•	•	•			
	3	14-3/4	713F3563	•	•	•	•			
	3.5	16-1/2	713F3663	•	•	•	•			
	4	18-1/4	713F3763	•	•	•	•			
	5	21-1/2	713F3863	•	•	•				
	6	24-3/4	713F3963	•	•	•				
	8	31-1/2	713F4063				•			
	10	38-1/4	713F4163				•			
	12	45	713F4263				•			
3	3	11-1/2	713F4363	•	•	•	•	•	•	•
	3.75	13	713F4463	•	•	•		•	•	•
	4.5	14-3/4	713F4563	•	•	•	•	•	•	•
	5.25	16-1/2	713F4663		•	•	•	•	•	•
	6	18-1/4	713F4763		•	•	•	•	•	•
	7.5	21-1/2	713F4863		•	•	•	•	•	•
	9	24-3/4	713F4963			•	•	•	•	•
	12	31-1/2	713F5063				•	•	•	•
	15	38-1/4	713F5163					•	•	•
	18	45	713F5263					•	•	•

B Dimensions (Inches)	With Built-in Thermostat					
	Availability					
	1 Phase		3 Phase			
120V	208V	240V	480V	208V	240V	480V
11-1/2	•	•	•			
14-3/4	•	•	•	•		
18-1/4	•	•	•	•		
21-1/2	•	•	•	•		
24-3/4	•	•	•	•		
31-1/2	•	•	•	•		
38-1/4		•	•	•		
45		•	•	•		
11-1/2	•	•	•		•	•
13	•	•	•		•	•
14-3/4	•	•	•	•	•	•
16-1/2		•	•	•	•	•
18-1/4		•	•	•	•	•
21-1/2		•	•	•	•	•
24-3/4			•	•	•	•
31-1/2				•	•	•
38-1/4					•	•
45						•

Please specify volts, phase and thermostat range if needed. Use the table on page 33 to specify the Temperature Code Rating.

CSA Listed Explosion-proof Heaters

Oil Heaters

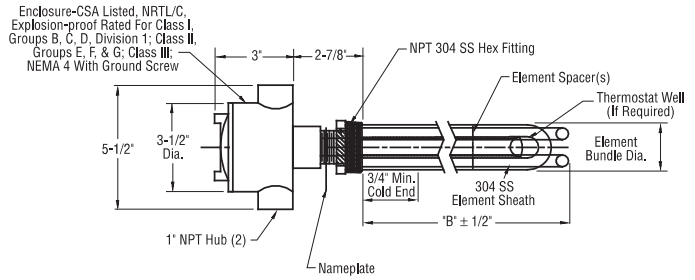
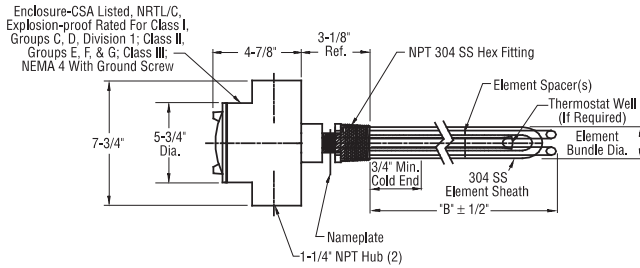

304 SS Sheath, 304 SS Fitting

20 W/Sq. In.

Number Of Elements	KW	Without Thermostat		Availability							
		B Dimensions (Inches)	Catalog Number	1 Phase				3 Phase			
				120V	208V	240V	480V	208V	240V	480V	
1	1	21-1/2	713F0063	•	•	•	•				
	1.5	30	713F0163	•	•	•	•				
	2	38-1/4	713F0263	•	•	•	•				
	2.5	46-3/4	713F0363	•	•	•	•				
	3	55	713F0463	•	•	•	•				
2	1	13	713F0563	•	•	•	•				
	1.5	17-1/4	713F0663	•	•	•	•				
	1.75	19-1/4	713F0763	•	•	•	•				
	2	21-1/2	713F0863	•	•	•	•				
	2.25	23-1/2	713F0963	•	•	•	•				
	2.5	25-3/4	713F1063	•	•	•	•				
	3	30	713F1163	•	•	•	•				
	4	38-1/4	713F1263	•	•	•	•				
	5	46-3/4	713F1363		•	•	•				
3	1.5	12-3/4	713F1563	•	•	•	•	•	•		
	2.25	17-1/4	713F1663	•	•	•	•	•	•	•	•
	3	21-1/2	713F1763	•	•	•	•	•	•	•	•
	3.75	25-3/4	713F1863	•	•	•	•	•	•	•	•
	4.5	30	713F1963	•	•	•	•	•	•	•	•
	6	38-1/4	713F2063		•	•	•	•	•	•	•
	7.5	46-3/4	713F2163		•	•	•	•	•	•	•
	9	55	713F2263			•	•	•	•	•	•
	10	60-1/2	713F2363				•	•	•	•	•
	12	71-1/2	713F2463				•	•	•	•	•

B Dimensions (Inches)	With Built-In Thermostat							
	Availability				Availability			
	120V	208V	240V	480V	208V	240V	480V	
21-1/2	•	•	•	•				
30	•	•	•	•				
38-1/4	•	•	•	•				
46-3/4	•	•	•	•				
55	•	•	•	•				
13	•	•	•	•				
17-1/4	•	•	•	•				
19-1/4	•	•	•	•				
21-1/2	•	•	•	•				
23-1/2	•	•	•	•				
25-3/4	•	•	•	•				
30	•	•	•	•				
38-1/4	•	•	•	•				
46-3/4		•	•	•				
55		•	•	•				
12-3/4	•	•	•	•	•	•	•	
17-1/4	•	•	•	•	•	•	•	
21-1/2	•	•	•	•	•	•	•	
25-3/4	•	•	•	•	•	•	•	
30	•	•	•	•	•	•	•	
38-1/4		•	•	•	•	•	•	
46-3/4		•	•	•	•	•	•	
55			•	•	•	•	•	
60-1/2				•	•	•	•	
71-1/2				•	•	•	•	

Please specify volts, phase and thermostat range if needed. Use the table on page 33 to specify the Temperature Code Rating.

Tank and Basin Heaters

Pipe Insert Heaters

Open Coil Pipe Insert Heaters are designed to insert into a horizontal 3" pipe mounted just above the anticipated sludge level in the tank and below the expected minimum operational fluid level. These units provide a low watt density over a large surface area and are used to heat sensitive fluids. Advantages include the ability to change the heater without draining the tank and to provide up to a Schedule 80 pipe wall in mildly corrosive fluids.

Heater pipes can be customer supplied or provided by INDEECO. Pipes can be welded into the tank wall or can be attached with an ANSI flange. INDEECO can also provide a weather-resistant terminal box with NPT threads attached to the end of the heater pipe.

Consult the factory for custom heaters not represented in the following chart.

Catalog Number	Pipe Length (Inches)	KW at 480V 15 W/Sq. In.
797-129915	48	3.95
797-129916	60	5.5
797-129917	72	7.25
797-129918	84	9
797-129919	96	10.5
797-129920	108	12
797-129921	120	14
797-129922	132	16.5
797-129923	144	17.5
797-129924	156	19
797-129925	168	20

Based on a 12" cold length.

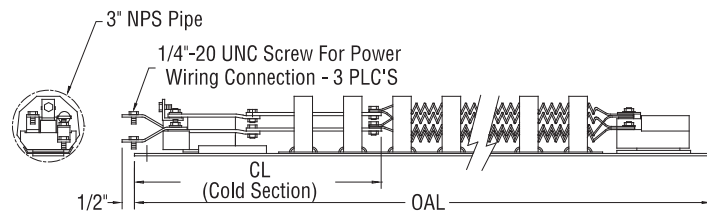

Deep Tank Heaters

Deep Tank Heaters are designed to fit into a manhole of an enclosed tank or double wall tank installed either above or below grade. Often the riser is "split" to facilitate installation. Watt densities can vary from 50 W/Sq. In. for water applications to 5 W/Sq. In. for heavy fuel oils. Controls are often provided to avoid penetrating the tank elsewhere. The element bundle diameter can range from a 12" O.D. to a maximum of 22" O.D.

Steel NEMA 4 Box

12 W/Sq. In.

Number of Elements	KW	Dimensions (Inches) E	Catalog Number	Availability			
				1 Phase		3 Phase	
				480V	208V	240V	480V
3	5	6	747N063	•	•	•	•
6	7.5	9-1/2	747N073	•	•	•	•
9	10	13-1/4	747N083	•	•	•	•
12	15	17	747N093	•	•	•	•
18	20	24-3/4	747N103	•	•	•	•
24	30	32	747N113	•	•	•	•

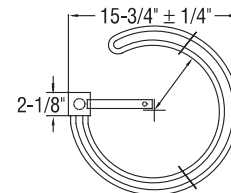
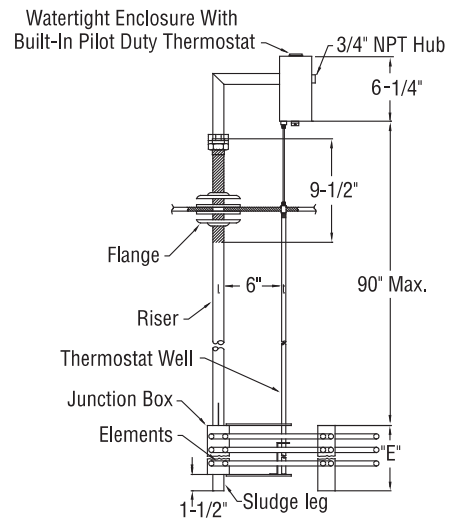

Consult factory for pilot duty thermostat options.

Tank and Basin Heaters

Cooling Tower Heaters

Cooling Tower Heaters are long cartridge heaters designed with a conservative 25 W/Sq. In. maximum watt density. These units provide a long “gentle” heat covering a majority of the tank or vessel. They are used primarily in below grade concrete sumps, for cooling towers or to heat viscous fluids. The heaters can be specified with through-the-wall or over-the-side construction in 3/4” NPT (Series 761) or 1-1/4” NPT (Series 762).

Over-the-Side Heaters eliminate the need for cutting a hole in the basin. Internal wiring runs from the horizontal heater elements through a vertical riser and extension arm with an outlet box located over the side of the basin.

Adjustable Sludge Legs are furnished on all heaters. Located on five foot centers to keep the element in place even in high water velocities, these legs are adjustable for heights between 2” and 3-1/2”.

Liquidproof/Explosion-Resistant Outlet Boxes are furnished on all heaters.

Through-the-Wall Heaters

Series	NPT (Inches)	DIA (Inches)
761	3/4	3/4
762	1-1/4	1-5/16

**Through-the-Wall Cooling Tower Heater
NEMA 4/7 Terminal Box**

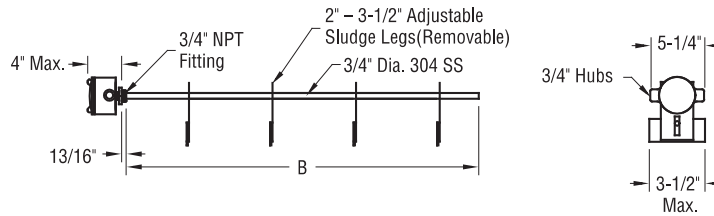

**Over-the-Side Cooling Tower Heater
NEMA 4/7 Terminal Box**

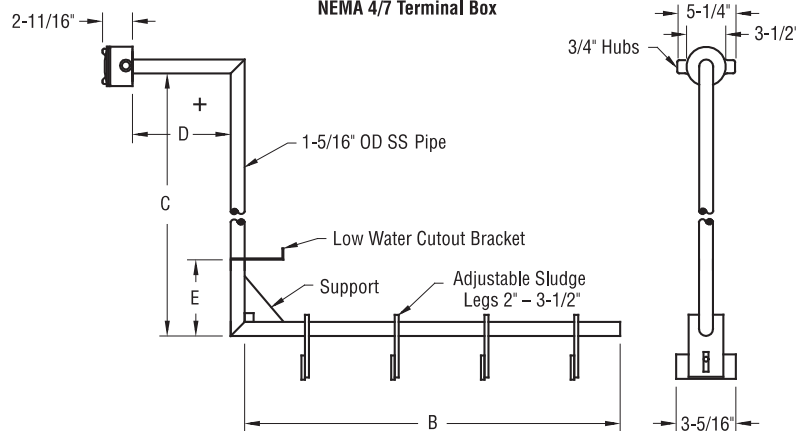

Note: Dimensions B, C, D and E (if required) must be specified when ordering.

Tank and Basin Heaters

Cooling Tower Heaters (continued)

761 Series (3/4" NPT) NEMA 4 Box		
B Dimension (Inches)	Catalog Number	Maximum KW
24	761U024	1.2
30	761U030	1.6
36	761U036	2.0
42	761U042	2.4
48	761U048	2.8
54	761U054	3.2
60	761U060	3.6
66	761U066	4.0
72	761U072	4.4
78	761U078	4.8
84	761U084	5.2
90	761U090	5.6
96	761U096	6.0
102	761U102	6.4
108	761U108	6.8
114	761U114	7.2
120	761U120	7.6
126	761U126	8.0
132	761U132	8.4
138	761U138	8.8
144	761U144	9.2
150	761U150	9.6
156	761U156	10.0
162	761U162	10.4
168	761U168	10.8

762 Series (1-1/4" NPT) NEMA 4 Box		
B Dimension (Inches)	Catalog Number	Maximum KW
24	762U024	2.2
30	762U030	2.8
36	762U036	3.4
42	762U042	4.0
48	762U048	4.6
54	762U054	5.2
60	762U060	5.8
66	762U066	6.4
72	762U072	7.0
78	762U078	7.6
84	762U084	8.3
90	762U090	9.0
96	762U096	9.7
102	762U102	10.5
108	762U108	11.3
114	762U114	12.0
120	762U120	12.7
126	762U126	13.4
132	762U132	14.1
138	762U138	15.0
144	762U144	16.0
150	762U150	17.0
156	762U156	18.0
162	762U162	19.0
168	762U168	20.0

Contactor Control Panels

INDEECO can provide a control system for any electric process heating application. Our experienced engineering staff can design control systems ranging from ON/OFF logic to full SCR with PID logic. Optional features include ramp/soak, computer interface capability and various control schemes as required.

INDEECO offers two standard control panel designs: Full SCR PID control and ON/OFF contactor control. All components are factory mounted and wired in compliance with the National Electric Code.

These charts are a sample of standard control panel designs. Custom control panels, designed specifically for a customer's application, are available.

A Vernier type control panel can also be supplied. Vernier type control utilizes contactors, one SCR controller, and a microprocessor-based sequencer. The sequencer controls the staging of the contactors and the SCR controller. The SCR controller serves to fill in the gaps between the step-controlled stages. Vernier type control is not quite as accurate as full SCR control, but more accurate than contactor (step) control.

This contactor-based system with ON/OFF process temperature control is recommended for less demanding applications. Systems with two or more heating stages utilize an INDEECO Controls electronic sequencer (step controller), driven by a proportional output temperature controller to minimize the amount of load cycling while providing good outlet temperature control.

Standard Features:

- INDEECO microprocessor-based sequencer (for panels with two or more heating stages)
- Indicating PID temperature controller (adjustable process temperature with thermocouple input)
- NEMA 12 painted steel enclosure, wall mount unless otherwise noted
- Overtemperature controller (adjustable temperature limit with thermocouple input)
- Door interlock disconnect switch
- Manual reset pushbutton with built-in pilot light (red) for visual "OVERTEMPERATURE" alarm
- Selector switch – ON/OFF with built-in pilot light (green) for "POWER ON" indication
- Control power transformer
- Disconnecting magnetic contactors
- Circuit fusing

Amps	No. of Circuits	Amps Per Circuit	Maximum KW		Approximate Dimensions (Inches)			Estimated Weight (lb.)
			240V/3Ph	480V/3Ph	Height	Width	Depth	
48	1	48	19	39	24	24	8	85
96	2	48	39	79	30	24	8	105
144	3	48	59	119	36	30	8	160
192	4	48	79	159	42	30	8	175
240	5	48	99	199	48	36	8	260
288	6	48	119	239	48	36	8	265
336	7	48	139	279	60	36	8	320
384	8	48	159	319	60	36	8	330
432*	9	48	179	359	60	48	12	585
480*	10	48	199	399	60	48	12	600
528*	11	48	219	438	60	60	12	680
576*	12	48	239	478	60	60	12	685
624*	13	48	259	518	72	60	12	800
672*	14	48	279	558	72	60	12	805
720*	15	48	299	598	72	60	12	815
768*	16	48	319	638	72	72	12	930
816*	17	48	339	678	72	72	12	945
864*	18	48	359	718	72	72	12	950
912*	19	48	379	758	72	72	12	960
960*	20	48	399	798	72	72	12	965

Control Panels

SCR Control Panels

A full SCR control system with PID temperature control is recommended for industrial heating applications which must accommodate material flow changes and provide the highest degree of accuracy for outlet temperature control.

Standard Features:

- PID self-tuning temperature controller (adjustable process temperature, with thermocouple input)
- INDEECO three-phase, zero cross-fired, SCR power controllers
- NEMA 12 painted steel enclosure, wall mount unless otherwise noted
- Overtemperature controller (adjustable temperature limit with thermocouple input)
- Door interlock disconnect switch
- Manual reset pushbutton with built-in pilot light (red) for visual "OVERTEMPERATURE" alarm
- Selector switch – ON/OFF with built-in pilot light (green) for "POWER ON" indication
- Control power transformer
- Safety contactors
- Circuit fusing
- Ventilating fan and filter when required

Amps	No. of Circuits	Amps Per Circuit	Maximum KW		Dimensions (Inches)			Estimated Weight (lbs)
			240V/3PH	480V/3PH	Height	Width	Depth	
SCR panels with externally mounted heat sinks								
48	1	48	19	39	24	24**	8	95
70	1	70	29	58	30	24**	8	115
96	2	48	39	79	30	24**	8	125
140	2	70	58	116	42	30**	8	205
144	3	48	59	119	36	30**	8	195
210	3	70	87	174	48	36**	8	310
192	4	48	79	159	42	30**	8	225
280	4	70	116	232	60	36**	8	385
240	5	48	99	199	48	36**	8	320
350	5	70	145	290	60	36**	8	415
SCR panels with internally mounted heat sinks, fan and filter								
295	6	48	119	239	60	36	16	405
425*	9	47	175	351	60	48	16	660
590*	12	48	329	478	60	60	16	750
850*	18	47	351	703	72	72	16	1090

* These panels have double doors and 12" high floor stands.

** Additional 9" clearance required for externally mounted heat sinks which may be mounted on one or both sides of the enclosure for proper convection cooling.

SCR Power Controllers modulate the entire heater load directly, varying the heater output from 0 to 100% of the total heater KW. Working on a four second time base, the heater will be energized only for the number of AC cycles necessary to produce the exact amount of heat required. The resulting precision control and rapid response make the INDEECO Controls SCR the choice for many heating applications. For example, multi-stage discharge temperature control of a heater can produce unacceptable temperature swings, resulting in inefficient energy use. The same heater controlled by the SCR and

process temperature controller will produce stable, even heat for maximum performance and efficiency.

The SCR's power switching devices are mounted on a large finned heat sink which extends outside the heater terminal box or control panel. The conservative SCR rating and this generous heat sink insures against overheating and SCR failure.

Cooling Tower Control Panels

INDEECO offers a pre-engineered, UL Listed/CSA Approved package for freeze protecting cooling tower basins.

The complete package includes:

- Electric Immersion Heater(s)
- Control Panel with Solid-State Printed Circuit Board
- Sensor Probe with Cord
- Wiring Diagram
- Installation and Operating Instructions

INDEECO offers the following options:

- Disconnect Switch
- Fuses
- Circuit Breaker



INDEECO Heater Control Panels offer these advantages:

Solid-State Control

Outmoded bulb and capillary control has been replaced with new patented solid-state technology which combines temperature control with low water level protection in a single solid-state device.

NEMA 4X Enclosure

All controls are factory wired inside a rugged NEMA 4X enclosure designed for wet, outdoor use. Pre-engineered designs up to 96 amps are available with stock and built-to-order listings.

Lower Cost

Installation time and cost are reduced by replacing individually mounted temperature and liquid level control devices with one pre-engineered and assembled control package that requires only one probe to sense both water temperature and level.

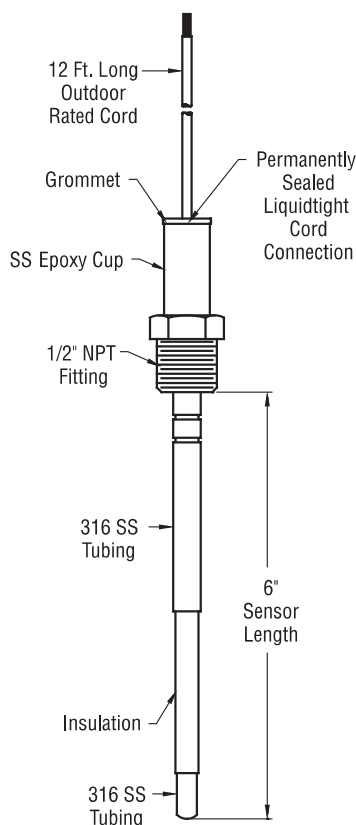

Sensor Probe Specifications:

- Sensor Probe: INDEECO probe assembly incorporating both temperature and liquid level sensors. Probe is made out of 316 stainless steel to minimize corrosion. Probe can be installed vertically or horizontally.
- Maximum Pressure Rating for Sensor Probe: 15 psi
- Cord: 12-foot outdoor rated cord with PVC hub connector for installation through tower basin wall. Options include different cord lengths or cord suitable for total immersion.

Cooling Tower Control Panel Specifications:

- Solid-State Control: Pre-set 45° F ON/OFF temperature control with 5° F switching differential and built-in low water cutoff. Circuit board LED's provide visual indication of heater-on and liquid level status.
- Ambient Temperature Range: -40° F to 150° F
- Fail Safe: Output relay is de-energized if the input sensor is either open or short-circuited. This prevents heater burn-out problems.
- NEMA 4X enclosure with pre-mounted electrical hubs for conduit connections.
- Single probe to sense both water temperature and water level. Sensor probe supplied with 12-foot outdoor rated cord pre-connected to control panel. Probe also supplied with PVC hub connector for attachments through cooling tower basin wall.
- Nameplate showing maximum KW and amp ratings at system volts/phase.
- System Wiring Diagram.
- Installation and Operating Instructions.
- Rated for maximum of 40 amps or 50 amps with disconnect switch when specified.
- Suitable for multiple heaters per basin (maximum of 2 on 40 amp panel).
- Disconnect switch with door interlock and operator handle, which can be padlocked in the "OFF" position.
- Dimensions: 8" x 10" x 6" for 40 amp size
10" x 12" x 7" for 50 amp size
14" x 16" x 8" for two circuits
- Control panels rated greater than 50 amps are supplied with two circuits and offered either with built-in fusing or a circuit breaker for each circuit.

Thermostats and Accessories

Thermostats

Thermostats may be mounted inside a terminal enclosure or remote mounted (separate from the heater assembly). If using a remote mounted thermostat, be sure to order sufficient capillary tube length to permit installation.

Thermostats regulate temperature in non-critical applications. They sense temperature, within a preset range and cycle heaters on and off to maintain the set point.

Type DA

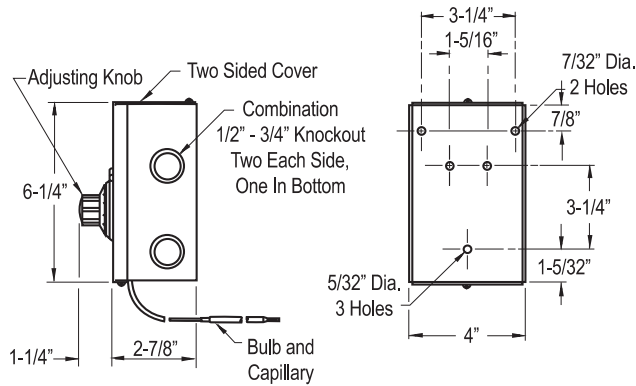

Type EC

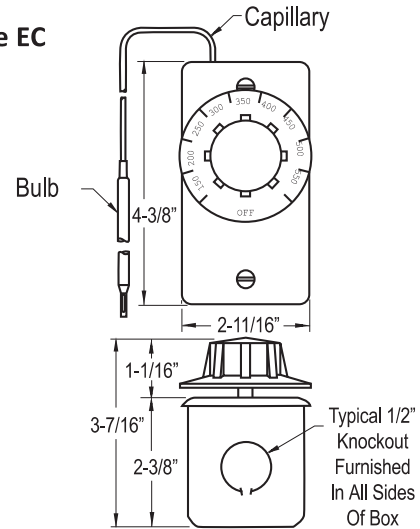

Type DA Thermostats

Range °F	Poles	Capillary Length (Inches)	Bulb & Capillary Material	Bulb Size (Dia. x Length) (Inches)	Catalog Number
0-100	2	12	Copper	3/8 x 4-1/8	DA1-6A12
0-100	3	48	Copper	3/8 x 4-1/8	DA3-6A48
60-250	2	48	Copper	3/16 x 15-3/8	HA1-3C96*
60-250	2	96	Copper	3/8 x 4-1/2	DA1-6C96

* combination thermostat/thermal cutout. Thermal cutout temperature is 50° F above the control set point

Type EC Thermostats

Catalog Number	Range °F	Bulb Size (Dia. x Length) (Inches)	Capillary Length (Inches)	Bulb & Capillary Material	One-Pole, Capacity in KW		
					120V	208V	240V
EC1-6A120	0-100	3/8 x 6	120	Copper	3	5.2	6
EC1-6C36	60-250	3/8 x 4-1/2	36	Copper			
EC1-3D36	150-550	3/16 x 11-3/4	36	Steel			

Pilot duty rating is 125VA at 240 volts maximum, resistive rating of 25 amp up to 250 volts. All thermostats are available in a painted steel NEMA 4 enclosure.

Thermostats and Accessories

Wells

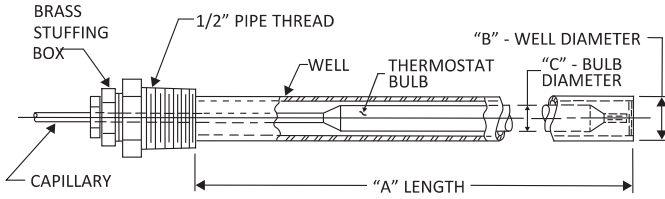

Wells are used to protect the bulb from corrosion or for mechanical support. Each well is furnished with a brass stuffing box to hold the capillary in place after installation. To order, specify catalog number and thermostat type.

Catalog Number (Stainless)	Dimensions (Inches)		
	A	B	C
WSS12A	12	5/16	3/16
WSS18A	18		
WSS24A	24		
WSS36A	36		
WSS06B	6	9/16	3/8
WSS12B	12		
WSS18B	18		
WSS24B	24		

Pipe Thread Connectors

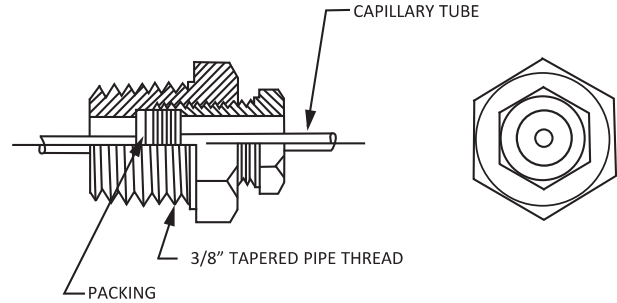

Pipe thread connectors (stuffing boxes) are used to make a liquid-tight connection where the bulb goes through a tank wall. If the wall is thick enough, it may be drilled and tapped to receive the stuffing box thread. Otherwise, a coupling must be provided.

Part Number	Application		
	Bulb Dia. (Inches)	Thermostat Type	Material
1000874	3/16	DA or EC	Stainless
1000844	3/8	DA or EC	Brass
1024649	3/8	DA or EC	Nickel/Brass

Thermostats and Accessories

Magnetic Contactors

Two-Pole Contactors for Single-Phase Circuits

Catalog Number	Current Rating (Amps/Pole) Resistive	Overall Case Dimensions (Inches)			Wt. Lb.	Holding Coil VA Ratings		Rating in KW (Not Amps)					
		Height	Width	Depth		Inrush	Holding	120V	208V	240V	277V	480V	600V
120-13L	40*	6-1/2	5-7/8	4	2-1/2	55	5.5	4.8	8.3	9.6	11.0	19.2	18.0
120-15A	50	6-1/2	5	4	2-1/2	55	5.5	6.0	10.4	12.0	13.8	24.0	30.0
120-26A	75	10-7/16	5-11/16	6-1/4	15-1/2	92	10	9.0	15.6	18.0	20.7	36.0	45.0
120-28	90	14-3/8	8-3/8	5-3/8	18	440	45	10.8	18.7	21.6	24.9	43.2	54.0
▲120-230 MTE	30	8-7/8	6-3/8	4-1/4	6	18	11	3.6	6.2	7.2	8.3	—	—

Three-Pole Contactors for Three-Phase Circuits

Catalog Number	Current Rating (Amps/Pole) Resistive	Overall Case Dimensions (Inches)			Wt. Lb.	Holding Coil VA Ratings		Rating in KW (Not Amps)					
		Height	Width	Depth		Inrush	Holding	120V	208V	240V	277V	480V	600V
120-14K	40*	6-1/2	5	4	2-1/2	55	5.5	—	14.4	16.6	—	33.2	31.1
120-16K	50	6-1/2	5	4	2-1/2	55	5.5	—	18.0	20.7	—	41.5	51.9
120-27A	75	10-7/16	5-11/16	6-1/4	15-1/2	92	10	—	27.0	31.1	—	62.3	77.9
120-29	90	14-3/8	8-3/8	5-3/8	18	440	45	—	32.4	37.4	—	74.8	93.5
120-41	125	10	11	5-1/4	27	440	45	—	45.0	51.9	—	103.9	129.9
120-41B	160	22-1/8	12-7/8	6-1/4	37	957	75	—	57.6	66.5	—	133.0	166.2
▲120-330 MTE	30	10-1/4	9-1/8	5	9	23	18	—	10.8	12.4	—	—	—

▲ Mercury Contactor

*Current rating decreases to 30 amps/pole for voltages greater than 480.

Myers Scru-Tite Hub

Pipe Size (Inches)	K (Inches)		Part Number	
	Min	Max	Zinc	Stainless Steel
1/2	55/64	7/8	1007184	1019099
3/4	1-1/16	1-1/8	1007190	1000565
1	1-21/64	1-3/8	1000101	1000523
1-1/4	1-43/64	1-3/4	1007193	1000509
1-1/2	1-59/64	2	1000115	1019098
2	2-25/64	2-1/2	1000087	1000136
2-1/2	2-57/64	3	1000129	—
3	3-33/64	3-5/8	1000176	—
3-1/2	4-1/64	4-1/8	1000192	—
4	4-33/64	4-5/8	1000208	—

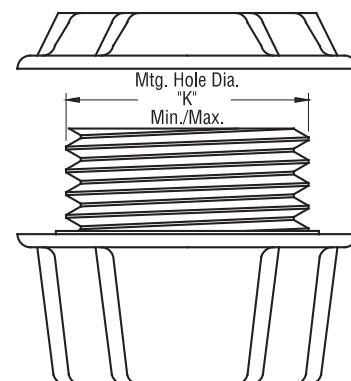

Special Purpose Heaters

Bottom-Mounted Heaters

Bottom-Mounted immersion heaters were originally designed for use in coffee urns. However, their compact construction makes them ideal for use in steam tables, humidifiers, sterilizers and other applications requiring a very low heater profile and a short element length.

Standard Construction

Bottom-Mounted immersion heaters are made with either two or three copper-sheathed tubular elements that are silver soldered to a threaded brass fitting. The fitting is installed through a 2-7/16" diameter hole in the bottom of the vessel, and secured to the vessel by a brass hex nut. The hex nut is an integral part of the NEMA 1 terminal box, which is standard on all units.

Since standard heaters are made only with copper elements, their use is confined to water or solutions not corrosive to copper or brass. All heaters are designed at a watt density of 50 watts per square inch or less.

Standard heaters are available in 120, 208 and 240 volts. Heaters with two elements are designed for single-phase operation, while three element heaters can also be used for single-phase applications where space limitations preclude the use of a two-element heater.

Special Features

Allen Head Fitting - For convenience of installation, an Allen head fitting can be furnished on a NEMA 1 outlet box. This allows installation with a 3/8" Allen wrench rather than the wide jaw wrench required to fit the large hex nut on the NEMA 1 box.

UL Listing - All standard Bottom-Mounted immersion heaters, with or without a low water cutout, are Listed by the Underwriters Laboratories under Reference E23541.

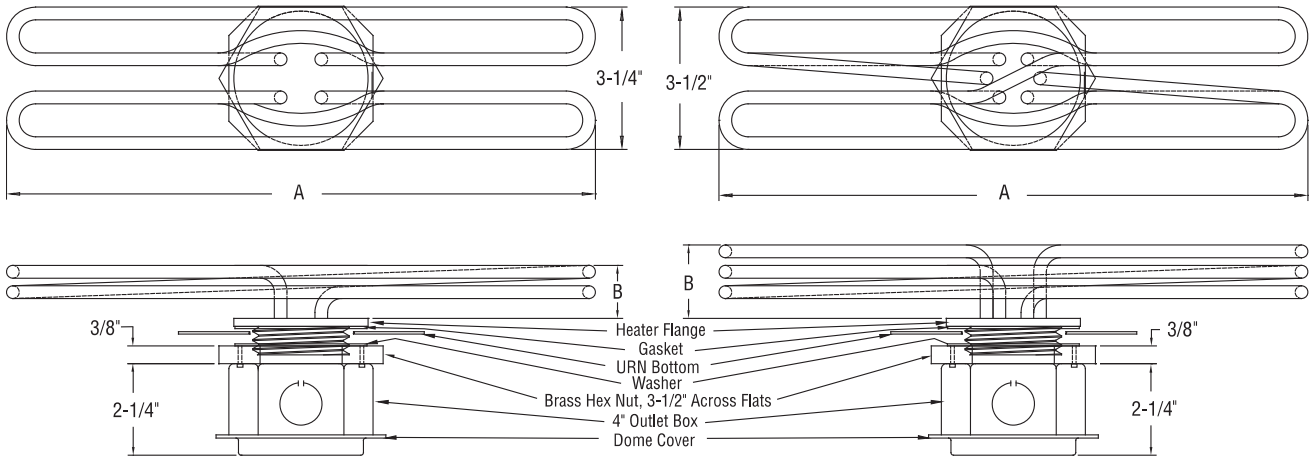

Number of Elements	KW	Catalog Number	A Dimensions (Inches)	B Dimensions (Inches)	Availability		
					1 Phase		
					120V	208V	240V
2	2	716N011	9-1/2	1		•	•
	3	716N021	8-1/2	1-1/2		•	•
	4	716N031	11-3/4	1-1/2		•	•
	5	716N041	12-3/4	1-1/2		•	•
	6	716N051	14-1/5	1-1/2		•	•

Number of Elements	KW	Catalog Number	A Dimensions (Inches)	B Dimensions (Inches)	Availability				
					1 Phase			3 Phase	
					120V	208V	240V	208V	240V
3	3	716N061	12-3/4	1-1/2	•	•	•	•	•
	4	716N071	13-3/4	1-1/2	•	•	•	•	•
	5	716N081	8-1/2	2-1/4		•	•	•	•
	6	716N091	10	2-1/4		•	•	•	•
	7	716N101	11-5/8	2-1/4			•	•	•
	9	716N111	15	2-1/4				•	•
	10	716N121	16-5/8	2-1/4				•	•
	12	716N131	17-3/8	2-1/4					•

Special Purpose Heaters

Rectangular Flange Heaters



Large Diameter Elements provide extra electrical insulation for superior dielectric strength. Because elements are .475" diameter, they are suitable for line voltages up to 600 volts. In addition, element insulation is compacted to insure uniform heat transfer from coil to sheath and all bends are repressed to insure insulation integrity in this critical area.

Flanges are fabricated from 3/16" minimum plate. Copper sheathed elements are silver soldered into brass flanges. Steel, Incoloy and stainless steel sheathed elements are welded into flanges of like materials.

Element Spacers, made from 304 stainless steel, maintain a uniform distance between elements, thus preventing hot spots where elements may otherwise touch.

Terminals are 10-32 studs, spot welded to the element cold pin and insulated from the sheath with mica or silicone rubber. Elements are interconnected at the factory with copper or stainless steel bus bars. Cupped washers are furnished for field connections on heaters drawing less than 40 amps. Pressure connectors are furnished for larger heaters.

Moisture-Resistant Epoxy Seals are standard on copper sheathed elements. When the maximum fluid temperature will not exceed 250° F., epoxy seals can be furnished on steel, Incoloy and stainless heaters at no extra charge.

Gaskets are furnished with each heater. A 1/16" pressed fiber gasket is standard.

Special Sheath Materials - Monel, Inconel 600 and Type 316 stainless steel are available for use with fluids that may corrode standard sheath materials. Compatible flange materials can also be furnished.

Alternate Flange Design - Non-standard flange sizes and bolt hole locations are available to match existing installations in the field.

Companion Flanges - A companion flange, made from the same material as the heater flange, is available with drilled and tapped openings matching the heater mounting holes. The companion flange is welded or brazed to the vessel, and the gasket installed between the heater flange and the companion flange.

Longer Element Cold Ends - Standard cold ends are 2-1/2" for copper, stainless and steel; 5-1/2" for Incoloy.

CSA Approval - CSA labeled units are available with construction modifications.

Series 770 Flange Heaters



Series 770 - 4-7/8" flange heaters, are three-element modules specifically designed for large steam or hot water boilers. They offer a simple, practical solution to two problems inherent in all electric boiler designs: element stocking and field replacement.

Series 770 heaters offer an attractive alternative to large pipe flange immersion heaters, which contain a multitude of elements and are therefore more difficult and more expensive to replace in the field. By using Series 770 heaters, element replacement is simplified; should an element burn out, it is only necessary to remove one small flange. The rest of the elements can remain in service. (Even when the elements are mounted into a pipe flange immersion heater with compression fittings, it is usually impractical to replace an element after the heater has been in service for some time, as the entire flange must be removed and elements tend to become encrusted with water deposits.)

Series 770 heaters are installed through a 2-3/8" diameter opening in a blind flange or a flat boiler head having a minimum thickness of 1-1/4". Eight 1/2" bolts hold the flange in place. Horizontally mounted elements must be supported at three-foot intervals.

Dimension Sheet Pipe Thread Heaters

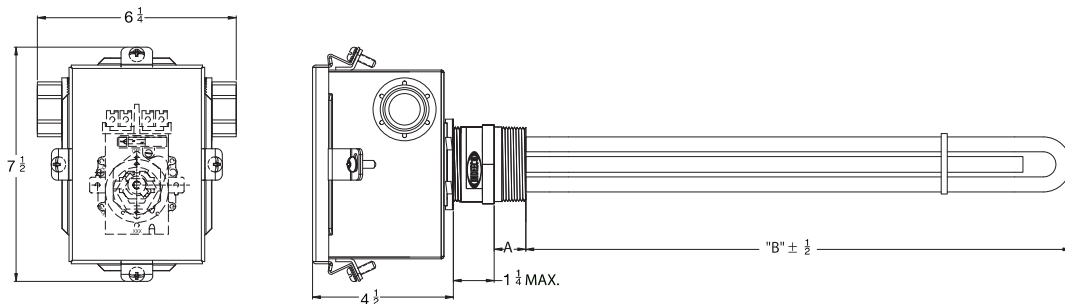
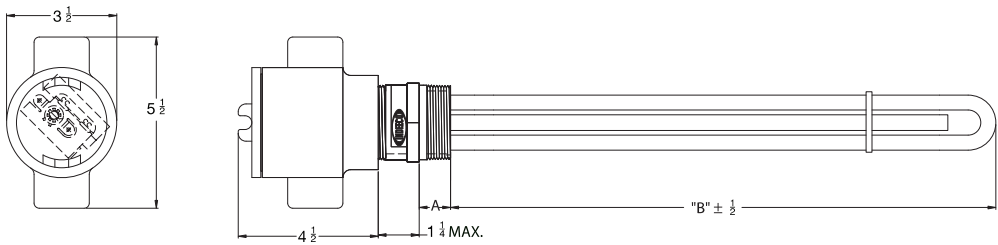
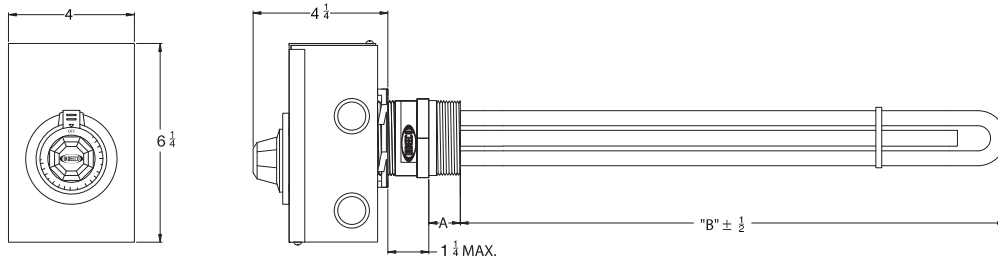
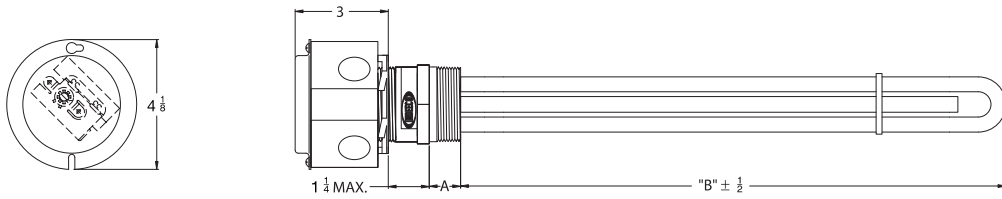

Dimension Sheet Pipe Thread Heaters

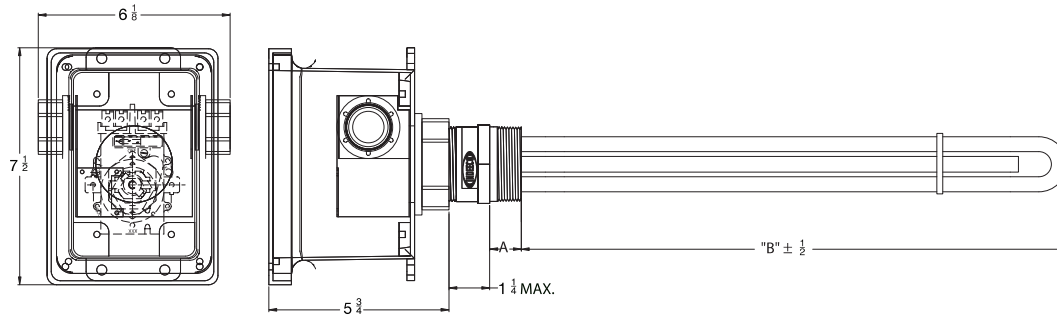

Figure 5

Thermostat and Terminal Box Selection

Fitting (Inches)	A (Inches)	Note
1	7/8	All pipethread fittings have identical terminal box dimensions. See Figures 1-5.
1-1/4	7/8	
2	1	
2-1/2	1-7/16	

Volts	Max KW	Thermostat	NEMA 1 Drawing	NEMA 4 Drawing	NEMA 4X Drawing
120/1	1.9	SPST load carrying	Figure 1	Figure 3	Figure 3
	3	SPST load carrying	Figure 1	Figure 4	Figure 5
	>3	SPST pilot duty*	Figure 1	Figure 4	Figure 5
208/1	3.3	SPST load carrying	Figure 1	Figure 3	Figure 3
	5.2	SPST load carrying	Figure 1	Figure 4	Figure 5
	>5.2	SPST pilot duty*	Figure 1	Figure 4	Figure 5
240/1	3.6	SPST load carrying	Figure 1	Figure 3	Figure 3
	6	SPST load carrying	Figure 1	Figure 4	Figure 5
	>6	SPST pilot duty*	Figure 1	Figure 4	Figure 5
480/1	4.8	DPST load carrying	Figure 2	Figure 4	Figure 5
	7.6	SPST pilot duty*	Figure 1	Figure 3	Figure 3
	>7.6	SPST pilot duty*	Figure 1	Figure 4	Figure 5
208/3	10.7	DPST load carrying	Figure 2	Figure 4	Figure 5
	>10.7	SPST pilot duty*	Figure 1	Figure 4	Figure 5
240/3	12.4	DPST load carrying	Figure 2	Figure 4	Figure 5
	>12.4	SPST pilot duty*	Figure 1	Figure 4	Figure 5
480/3	8.3	DPST load carrying	Figure 2	Figure 4	Figure 5
	13.2	SPST pilot duty*	Figure 1	Figure 3	Figure 3
	>13.2	SPST pilot duty*	Figure 1	Figure 4	Figure 5

* Requires customer supplied remote contactor and control voltage.

Note: If indicating light or off position required specify DPST thermostat.

Limited Warranty

Industrial Engineering and Equipment Company (INDEECO) products are warranted against defects in workmanship, material, design, labeling and packaging. No other warranty, expressed or implied, written or oral, applies. No person other than an officer or the general manager of INDEECO is authorized to give any other warranty or assume any liability.

Warranty Period: This warranty is effective for eighteen months from the date of shipment of the product from INDEECO's factory, or for twelve months from the date the product is first placed in service, whichever period lapses first.

Conditions of Warranty: INDEECO products must be installed, operated and maintained in accordance with INDEECO's instructions. INDEECO is not liable for damage or unsatisfactory performance of the product resulting from accident, negligence, alteration, unauthorized repair, improper application or installation of the product, improper specifications or corrosion. INDEECO IS NOT LIABLE FOR ANY INCIDENTAL OR CONSEQUENTIAL DAMAGES. Claims against carriers for damage in transit must be filed by the purchaser with the carrier.

Remedy: The part or product in question should be returned, freight prepaid, to:

INDEECO
425 Hanley Industrial Court
St. Louis, Missouri 63144
Attention: Return Goods Manager

If after receipt of the product and the claim, INDEECO finds to its reasonable satisfaction that the product is defective in workmanship, material, design, labeling or packaging, the product will be repaired or replaced or the purchase price refunded at INDEECO's option. There will be no charge to the purchaser for parts or labor. Removal and reinstallation of the product, and shipment of the product to INDEECO for repair or inspection shall be at the purchaser's risk and expense.

THE REPAIR, REPLACEMENT OR REFUND PROVIDED FOR IN THIS LIMITED WARRANTY IS THE EXCLUSIVE REMEDY OF THE PURCHASER. THIS WARRANTY IS EXPRESSLY IN LIEU OF ANY OTHER WARRANTIES, EXPRESSED OR IMPLIED, INCLUDING ANY WARRANTY OF MERCHANTABILITY OR FITNESS FOR A PARTICULAR PURPOSE. THERE ARE NO WARRANTIES WHICH EXTEND BEYOND THE TERMS OF THIS LIMITED WARRANTY.



INDUSTRIAL ENGINEERING & EQUIPMENT CO.
425 HANLEY INDUSTRIAL COURT
ST. LOUIS, MO 63144
314-644-4300
Fax: 314-644-5332
www.indeeco.com

FOR YOUR NEAREST INDEECO REPRESENTATIVE CALL:
800-243-8162