

# Heat Trace

Our products do more in a wide range of applications. **Expect More.**

# PRODUCTS INFORMATION GUIDE & ACCESSORIES

Indeeco offers a complete line of Heat Trace products for the most demanding freeze protection, temperature maintenance, snow melting, de-icing and specialty applications in industrial and commercial markets. These products are designed and manufactured to the strictest industry standards and are third-party approved for use in hazardous Industrial areas.



CRG® Heating Cables are designed for freeze protection of metal and plastic pipes as well as roof & gutter de-icing applications.  
150°F Maintain, 185°F Exposure, 120-277V operation, (3,5,8,10 w/ft)  
FM, CSA, UL



LSR® Heating Cables are designed for freeze protection and temperature maintenance of metal and plastic pipes.  
150°F Maintain, 185°F Exposure, 120-277V operation, (3,5,8,10 w/ft)  
FM, CSA, UL, CE



MSR® Heating Cables are designed for freeze protection and temperature maintenance of metal pipes and tanks.  
250°F Maintain, 366°F Exposure, 120-277V operation (5,10,15 w/ft)  
FM, CSA, CE



HSR® Heating Cables are designed for freeze protection and temperature maintenance of metal pipes and tanks.  
375°F Maintain, 450°F Exposure, 120-277V operation  
(5,10,15,20,25,30 w/ft)  
FM, CSA, CE



Mineral Insulated Cables and accessories are available for maintain temperatures to 900°F (482°C), exposure temperatures to 1100°F (593°C), operating voltages from 120 to 600 volts, and power output up to 50 watts per foot.

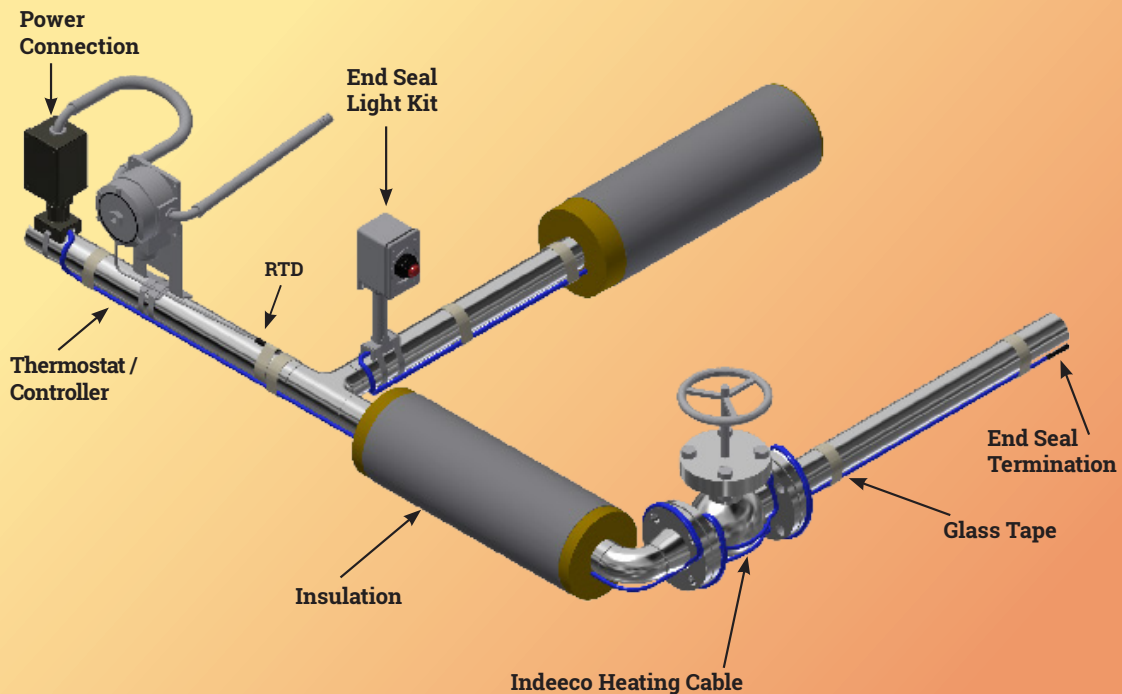

Heat trace controls and monitoring systems are available in: Single, Dual, and Multi Loop configurations for line and ambient sensing applications in ordinary and hazardous areas. These systems are designed and manufactured to insure your heat trace system reliability and integrity.



Mechanical thermostats are designed for ordinary and hazardous area use. Manufactured for high accuracy, single pole double throw contacts, 22 amps, 120 to 480 volt operation and ambient or line sensing.



## Self-Regulating Heating Cable

CRG® Heating Cables are designed for freeze protection of metal and plastic pipes and tanks in building and construction market applications. CRG® Cables are also designed and approved for use in roof & gutter de-icing applications. The semiconductive polymer core changes its power output versus pipe temperature to optimize power usage and prevent overheating. The cables are designed for extended service life, are third-party tested and approved to strict industry standards for building and construction market applications.

## SPECIFICATIONS

- Self-Regulating Power Output
- Continuous Maintenance Temperature
  - 150°F (65°C) Max
- Maximum Exposure Temperature
  - 185°F (85°C) Max
- Output Wattage (pipe application)
  - 3,5,8,10 W/FT @ 50°F
  - 10, 16, 26, 33 W/M @ 10°C
- Output Wattage (roof and gutter)
  - 10, 12, 16, 18 W/FT in snow/ice (32°F)
- Supply Voltage
  - 120, 208-277 VAC
- Size = 1/2" W x 1/4" H
- Minimum Bend Radius = 1 1/8"
- Minimum Install Temperature
  - 40°F (-40°C)
- Cut to Length and terminate in the field
- Can be overlapped without burnout

## CONSTRUCTION

- 16 AWG Nickel Plated Copper Buss Wires
- Radiation Cross Linked Polymer Heater Core
- Flame Retardant, UV Stabilized Polyolefin Jacket
- Tinned Copper Braid
- Optional Modified Polyolefin Outer Jacket
  - UV Stabilized
  - Flame Retardant
  - Protects Cable against aqueous inorganic Chemicals
- Optional Fluoropolymer Outer Jacket
  - Protects against organic and corrosive chemicals



## POWER OUTPUT CURVES

Power Output Curves shown below apply to cables used at service voltages shown below on insulated metal pipes. For Plastic pipe installation derate cable power output by 35% and use aluminum tape installation method. For other applications contact Indeeco.

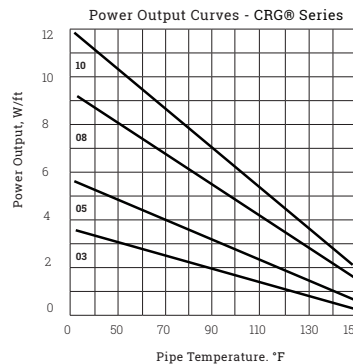

Power Adjustment Factor		
Model	208 Volts	277 Volts
CRG03-2	0.75	1.28
CRG05-2	0.86	1.16
CRG08-2	0.91	1.1
CRG10-2	0.93	1.08

## CONNECTION ACCESSORIES

All Cables require power connection and end seal terminations as a minimum to comply with third party requirements. Indeeco offers accessories to provide trouble free easy installation and maximum cable circuit life.

Accessories - Ordinary Area / Div 2 Hazardous Area		
Type	Ord Area	Model
Power Connection	x	PCA-40J
Pipe Stand Off Kit	x	PCA-40P
Splice/Tee Connection	x	SPTA-1
End Seal	x	ESA-ES
Lighted End Seal 120 V	x	LESA-1
Lighted End Seal 208-240V	x	LESA-2
Roof & Gutter - Power Connection	x	PCA-RG2
Roof & Gutter - Roof Clips (25/pk)	x	RC-RG
Roof & Gutter - Downspout Hangar (10/pk)	x	DS-RG
Thermostat - Ambient Sense	x	HTTS-A
Thermostat - Line Sense	x	HTTS-L
Application Tape	x	HTFT-1
Aluminum Foil Tape	x	HTAT-1
6 inch Pipe Strap	x	HTPS-6
10 Inch Pipe Strap	x	HTPS-10
Caution Label	x	HTCL-1

Note – Circuit lengths shown above are based on trip current characteristics of Type QO and Type QOB devices. For equipment with different trip current characteristics please consult Indeeco.

## CIRCUIT BREAKER SIZING

Maximum Circuit Lengths per start up temperature and circuit breaker size are shown below. Use local electrical codes to select appropriate branch circuit breakers. Ground Fault circuit breakers are required for heat trace branch circuits – typical minimum trip level is 30mA. Thermal magnetic circuit breakers are recommended to reduce nuisance tripping.

Maximum Circuit Length vs Breaker Size & Start-Up Temp FT (M)						
Model	Start-Up Temperature		15 A	20 A	30 A	40 A
	Deg F	Deg C				
CRG03-1	50 (10)		300 (92)	330 (100)	330 (100)	330 (100)
	0 (-18)		200 (60)	270 (82)	330 (100)	330 (100)
	-20 (-29)		180 (55)	230 (70)	330 (100)	330 (100)
CRG03-2	50 (10)		660 (200)	660 (200)	660 (200)	660 (200)
	0 (-18)		410 (125)	560 (170)	660 (200)	660 (200)
	-20 (-29)		360 (110)	480 (146)	660 (200)	660 (200)
CRG05-1	50 (10)		230 (70)	270 (82)	270 (82)	270 (82)
	0 (-18)		150 (45)	200 (60)	270 (82)	270 (82)
	-20 (-29)		130 (40)	175 (54)	260 (80)	270 (82)
CRG05-2	50 (10)		460 (140)	540 (165)	540 (165)	540 (165)
	0 (-18)		300 (92)	400 (122)	540 (165)	540 (165)
	-20 (-29)		260 (80)	345 (105)	520 (160)	540 (165)
CRG08-1	50 (10)		150 (45)	200 (60)	210 (64)	210 (64)
	0 (-18)		95 (30)	125 (38)	190 (58)	210 (64)
	-20 (-29)		85 (26)	100 (31)	170 (52)	210 (64)
CRG08-2	50 (10)		295 (90)	390 (119)	420 (128)	420 (128)
	0 (-18)		195 (60)	250 (76)	375 (115)	420 (128)
	-20 (-29)		170 (52)	225 (69)	340 (104)	420 (128)
CRG10-1	50 (10)		115 (35)	150 (45)	180 (55)	180 (55)
	0 (-18)		70 (22)	95 (30)	145 (44)	180 (55)
	-20 (-29)		60 (18)	85 (26)	120 (37)	165 (50)
CRG10-2	50 (10)		230 (70)	305 (93)	360 (110)	360 (110)
	0 (-18)		150 (45)	200 (60)	300 (92)	360 (110)
	-20 (-29)		130 (40)	175 (54)	260 (80)	360 (110)

Note – Circuit lengths shown above are based on trip current characteristics of Type QO and Type QOB devices. For equipment with different trip current characteristics please consult Indeeco.

## PRODUCT ORDERING INFORMATION

Ordering Information				
Output W/ft	Volts	Model	Stock	LBS/1000'
3 W/FT @ 50F	120	CRG03-11R00	S	80
		CRG03-11T00	S	80
	208-277	CRG03-21R00	S	80
		CRG03-21T00	S	80
5 W/FT @ 50F	120	CRG05-11R00	S	80
		CRG05-11T00	S	80
	208-277	CRG05-21R00	S	80
		CRG05-21T00	S	80
8 W/FT @ 50F	120	CRG08-11R00	S	80
		CRG08-11T00	S	80
	208-277	CRG08-21R00	S	80
		CRG08-21T00	S	80
10 W/FT @ 50 F	120	CRG10-11R00	S	80
		CRG10-11T00	S	80
	208-277	CRG10-21R00	S	80
		CRG10-21T00	S	80

Note = To order specify model, length, and connection accessories. Cables are shipped +/- 5% of label, maximum spool length 1000 feet, minimum order is 250 feet. No fee to cut to length between 250 and 1000 feet.

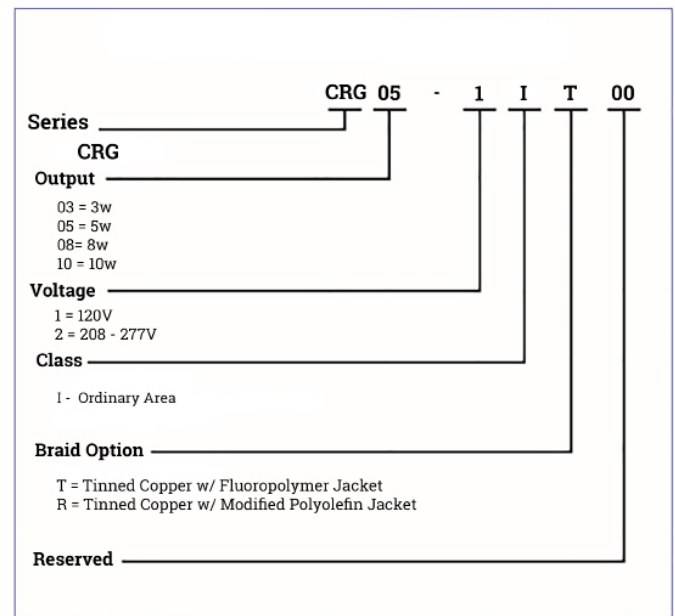

Note = CRG@ 5 w/ft cable 12 w/ft in snow and ice recommended for roof and gutter de-icing applications



## Self-Regulating Heating Cable

LSR® Heating Cables are designed for freeze protection and process temperature maintenance of metal and plastic pipes and tanks. The semiconductive polymer core changes its power output versus pipe temperature to optimize power usage and prevent overheating. The cables are designed for extended service life, are third-party tested and approved to strict industry standards for ordinary and hazardous area use.

### SPECIFICATIONS

- Self-Regulating Power Output
- Continuous Maintenance Temperature
  - 150°F (65°C) Max
- Maximum Exposure Temperature
  - 185°F (85°C) Max
- Output Wattage
  - 3,5,8,10 W/FT @ 50°F
  - 10, 16, 26, 33 W/M @ 10°C
- Supply Voltage
  - 120, 208-277 VAC
- T-Rating
  - 3,5,8 W/FT = T6
  - 10 W/FT = T5
- Size = 1/2" W x 1/4" H
- Minimum Bend Radius = 1 1/8"
- Minimum Install Temperature
  - 40°F (-40°C)
- Cut to Length and terminate in the field
- Can be overlapped without burnout

### CONSTRUCTION

- 16 AWG Nickel Plated Copper Buss Wires
  - Radiation Cross Linked Polymer Heater Core
  - Flame Retardant, UV Stabilized Polyolefin Jacket
  - Tinned Copper Braid
  - Optional Modified Polyolefin Outer Jacket
    - UV Stabilized
    - Flame Retardant
    - Protects Cable against aqueous inorganic Chemicals
- Optional Fluoropolymer Outer Jacket
- Protects against organic and corrosive chemicals



### POWER OUTPUT CURVES

Power Output Curves shown below apply to cables used at service voltages shown below on insulated metal pipes. For Plastic pipe installation derate cable power output by 35% and use aluminum tape installation method. For other applications contact Indeco.

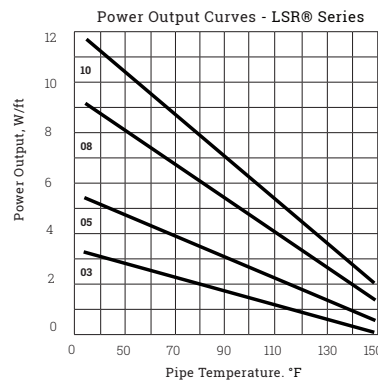

Power Adjustment Factor		
Model	208 Volts	277 Volts
LSR03-2	0.75	1.28
LSR05-2	0.86	1.16
LSR08-2	0.91	1.1
LSR10-2	0.93	1.08

### CONNECTION ACCESSORIES

All Cables require power connection and end seal terminations as a minimum to comply with third-party requirements. Indeco offers accessories to provide trouble free easy installation and maximum cable circuit life.

Accessories - Ordinary Area / Div 2 Hazardous Area			
Type	Ord Area	Div 2	Model
Power Connection	x	x	PCA-40J
Pipe Stand Off Kit	x	x	PCA-40P
Splice/Tee Connection	x	x	SPTA-1
End Seal	x	x	ESA-ES
Lighted End Seal 120 V	x	x	LESA-1
Lighted End Seal 208-240V	x	x	LESA-2
Thermostat - Ambient Sense	x		HTTS-A
Thermostat - Line Sense	x		HTTS-L
Thermostat - Ambient Sense	x	x	HTTS-EPA
Thermostat - Line Sense	x	x	HTTS-EPL
Application Tape	x	x	HTFT-1
Aluminum Foil Tape	x	x	HTAT-1
6 inch Pipe Strap	x	x	HTPS-6
10 Inch Pipe Strap	x	x	HTPS-10
Caution Label	x	x	HTCL-1

## CIRCUIT BREAKER SIZING

Maximum Circuit Lengths per start up temperature and circuit breaker size are shown below. Use local electrical codes to select appropriate branch circuit breakers. Ground Fault circuit breakers are required for heat trace branch circuits – typical minimum trip level is 30mA. Thermal magnetic circuit breakers are recommended to reduce nuisance tripping.

Maximum Circuit Length vs Breaker Size & Start-Up Temp FT (M)					
Model	Start-Up Temperature Deg F Deg C	15 A	20 A	30 A	40 A
LSR03-1	50 (10)	300 (92)	330 (100)	330 (100)	330 (100)
	0 (-18)	200 (60)	270 (82)	330 (100)	330 (100)
	-20 (-29)	180 (55)	230 (70)	330 (100)	330 (100)
LSR03-2	50 (10)	660 (200)	660 (200)	660 (200)	660 (200)
	0 (-18)	410 (125)	560 (170)	660 (200)	660 (200)
	-20 (-29)	360 (110)	480 (146)	660 (200)	660 (200)
LSR05-1	50 (10)	230 (70)	270 (82)	270 (82)	270 (82)
	0 (-18)	150 (45)	200 (60)	270 (82)	270 (82)
	-20 (-29)	130 (40)	175 (54)	260 (80)	270 (82)
LSR05-2	50 (10)	460 (140)	540 (165)	540 (165)	540 (165)
	0 (-18)	300 (92)	400 (122)	540 (165)	540 (165)
	-20 (-29)	260 (80)	345 (105)	520 (160)	540 (165)
LSR08-1	50 (10)	150 (45)	200 (60)	210 (64)	210 (64)
	0 (-18)	95 (30)	125 (38)	190 (58)	210 (64)
	-20 (-29)	85 (26)	100 (31)	170 (52)	210 (64)
LSR08-2	50 (10)	295 (90)	390 (119)	420 (128)	420 (128)
	0 (-18)	195 (60)	250 (76)	375 (115)	420 (128)
	-20 (-29)	170 (52)	225 (69)	340 (104)	420 (128)
LSR10-1	50 (10)	115 (35)	150 (45)	180 (55)	180 (55)
	0 (-18)	70 (22)	95 (30)	145 (44)	180 (55)
	-20 (-29)	60 (18)	85 (26)	120 (37)	165 (50)
LSR10-2	50 (10)	230 (70)	305 (93)	360 (110)	360 (110)
	0 (-18)	150 (45)	200 (60)	300 (92)	360 (110)
	-20 (-29)	130 (40)	175 (54)	260 (80)	360 (110)

Note – Circuit lengths shown above are based on trip current characteristics of Type QO and Type QOB devices. For equipment with different trip current characteristics please consult Indeco.

## PRODUCT ORDERING INFORMATION

Ordering Information				
Output W/ft	Volts	Model	Stock	LBS/1000'
3 W/FT @ 50F	120	LSR03-11R00	S	80
		LSR03-11T00	S	80
	208-277	LSR03-21R00	S	80
		LSR03-21T00	S	80
5 W/FT @ 50F	120	LSR05-11R00	S	80
		LSR05-11T00	S	80
	208-277	LSR05-21R00	S	80
		LSR05-21T00	S	80
8 W/FT @ 50F	120	LSR08-11R00	S	80
		LSR08-11T00	S	80
	208-277	LSR08-21R00	S	80
		LSR08-21T00	S	80
10 W/FT @ 50 F	120	LSR10-11R00	S	80
		LSR10-11T00	S	80
	208-277	LSR10-21R00	S	80
		LSR10-21T00	S	80

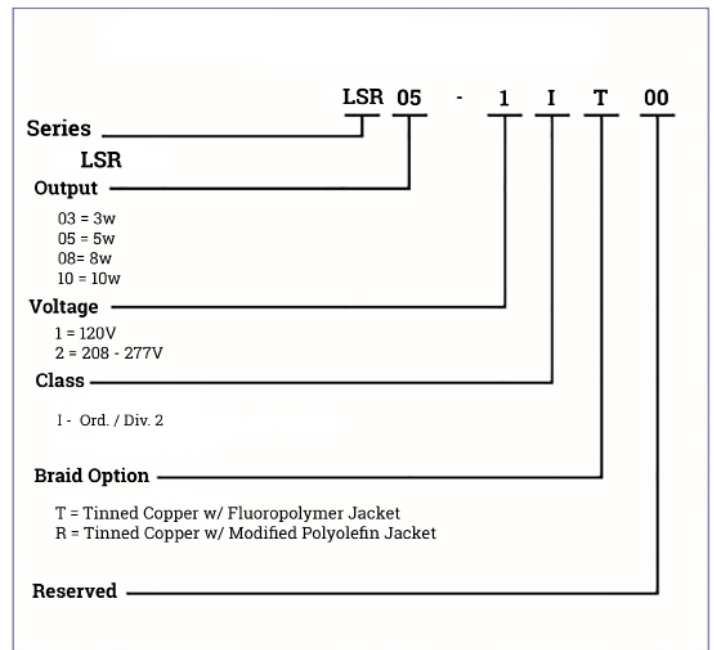

Note = To order specify model, length, and connection accessories. Cables are shipped +/- 5% of label, maximum spool length 1000 feet, minimum order is 250 feet. No fee to cut to length between 250 and 1000 feet.

## Self-Regulating Heating Cable

MSR® Heating Cables are designed for freeze protection and process temperature maintenance of metal pipes and tanks. The semiconductive polymer core changes its power output versus pipe temperature to optimize power usage and prevent overheating. The cables are designed for extended service life, are third-party tested and approved to strict industry standards for ordinary and hazardous area use.

## SPECIFICATIONS

- Self-Regulating Power Output
- Continuous Maintenance Temperature
  - 250°F (120°C) Max
- Maximum Exposure Temperature
  - 366°F (185°C) Max
- Output Wattage
  - 5,10,15 W/FT @ 50°F
  - 16,33,49 W/M @ 10°C
- Supply Voltage
  - 120, 208-277 VAC
- T-Rating
  - 5,10,15 W/FT = T3
- Size = 9/16" W x 1/4" H
- Minimum Bend Radius = 1 1/8"
- Minimum Install Temperature
  - -40°F (-40°C)
- Cut to Length and terminate in the field
- Can be overlapped without burnout

## CONSTRUCTION

- 16 AWG Nickel Plated Copper Buss Wires
- Modified Fluoropolymer heater core
- Modified Fluoropolymer insulating jacket
- Tinned Copper Braid
- Modified Fluoropolymer Outer Jacket
  - Protects against organic, inorganic and corrosive chemicals

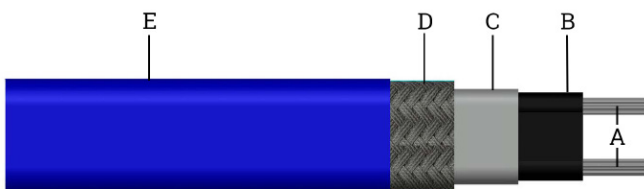

## POWER OUTPUT CURVES

Power Output Curves shown below apply to cables used at service voltages shown below on insulated metal pipes. For other applications contact Indeeco.

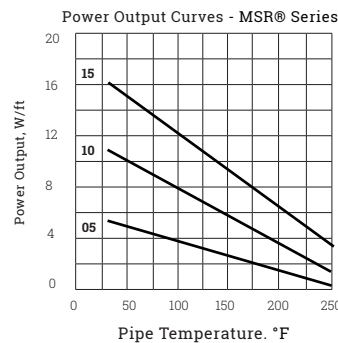

Power Adjustment Factor		
Model	208 Volts	277 Volts
MSR05-2	0.78	1.25
MSR10-2	0.86	1.16
MSR15-2	0.92	1.09

## CONNECTION ACCESSORIES

All Cables require power connection and end seal terminations as a minimum to comply with third party requirements. Indeeco offers accessories to provide trouble free easy installation and maximum cable circuit life.

Accessories - Ordinary Area / Div 2 Hazardous Area			
Type	Ord Area	Div 2	Model
Power Connection	x	x	PCA-40J
Pipe Stand Off Kit	x	x	PCA-40P
Splice/Tee Connection	x	x	SPTA-1
End Seal	x	x	ESA-ES
Lighted End Seal 120 V	x	x	LESA-1
Lighted End Seal 208-240V	x	x	LESA-2
Thermostat - Ambient Sense	x		HTTS-A
Thermostat - Line Sense	x		HTTS-L
Thermostat - Ambient Sense	x	x	HTTS-EPA
Thermostat - Line Sense	x	x	HTTS-EPL
Application Tape	x	x	HTFT-1
Aluminum Foil Tape	x	x	HTAT-1
6 inch Pipe Strap	x	x	HTPS-6
10 Inch Pipe Strap	x	x	HTPS-10
Caution Label	x	x	HTCL-1

## CIRCUIT BREAKER SIZING

Maximum Circuit Lengths per start up temperature and circuit breaker size are shown below. Use local electrical codes to select appropriate branch circuit breakers. Ground Fault circuit breakers are required for heat trace branch circuits – typical minimum trip level is 30mA. Thermal magnetic circuit breakers are recommended to reduce nuisance tripping.

Maximum Circuit Length vs Breaker Size & Start-Up Temp FT (M)					
Model	Start-Up Temperature Deg F Deg C	15 A	20 A	30 A	40 A
MSR05-1	50 (10)	150 (45)	200 (60)	240 (73)	240 (73)
	0 (-18)	135 (41)	180 (55)	220 (67)	220 (67)
	-40 (-40)	130 (40)	170 (52)	210 (64)	210 (64)
MSR05-2	50 (10)	250 (76)	330 (100)	480 (146)	480 (146)
	0 (-18)	230 (70)	305 (93)	440 (134)	440 (134)
	-40 (-40)	220 (67)	295 (90)	420 (128)	420 (128)
MSR10-1	50 (10)	90 (27)	120 (37)	180 (55)	180 (55)
	0 (-18)	85 (26)	110 (34)	165 (50)	165 (50)
	-40 (-40)	80 (24)	105 (32)	160 (49)	160 (49)
MSR10-2	50 (10)	140 (43)	190 (58)	280 (85)	280 (85)
	0 (-18)	130 (40)	175 (53)	260 (79)	260 (79)
	-40 (-40)	125 (38)	170 (52)	250 (76)	250 (76)
MSR15-1	50 (10)	70 (21)	90 (27)	130 (40)	130 (40)
	0 (-18)	65 (20)	85 (26)	125 (38)	125 (38)
	-40 (-40)	60 (18)	80 (24)	120 (37)	120 (37)
MSR15-2	50 (10)	100 (30)	135 (41)	200 (60)	200 (60)
	0 (-18)	95 (29)	125 (38)	185 (56)	185 (56)
	-40 (-40)	90 (27)	120 (37)	180 (55)	180 (55)

Note – Circuit lengths shown above are based on trip current characteristics of Type QO and Type QOB devices. For equipment with different trip current characteristics please consult Indeco.

## PRODUCT ORDERING INFORMATION

Ordering Information				
Output W/ft	Volts	Model	Stock	LBS/1000'
5 W/FT @ 50F	120	MSR05-11T00	S	80
	208-277	MSR05-21T00	S	80
10 W/FT @ 50F	120	MSR10-11T00	S	80
	208-277	MSR10-21T00	S	80
15 W/FT @ 50F	120	MSR15-11T00	S	80
	208-277	MSR15-21T00	S	80

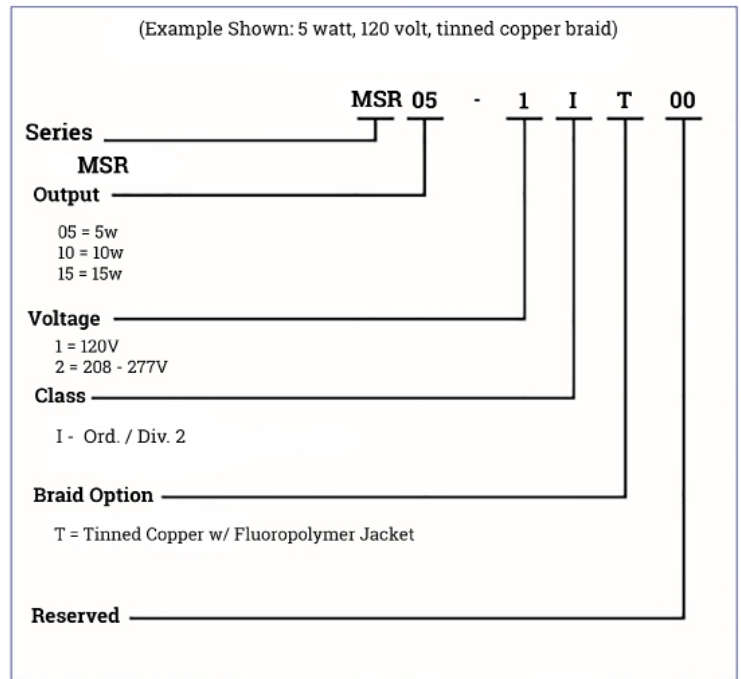

Note = To order specify model, length, and connection accessories. Cables are shipped +/- 5% of label, maximum spool length 1000 feet, minimum order is 250 feet. No fee to cut to length between 250 and 1000 feet.

## Self-Regulating Heating Cable

HSR® Heating Cables are designed for freeze protection and process temperature maintenance of metal pipes and tanks. The semiconductive polymer core changes its power output versus pipe temperature to optimize power usage and prevent overheating. The cables are designed for extended service life, are third-party tested and approved to strict industry standards for ordinary and hazardous area use.

## SPECIFICATIONS

- Self-Regulating Power Output
- Continuous Maintenance Temperature
  - 375°F (190°C) Max
- Intermittent Exposure Temperature
  - 450°F (232°C) Max
- Output Wattage
  - 5,10,15,20,25,30 W/FT @ 50°F
- Supply Voltage
  - 120, 208-277 VAC
- Temperature Classification: T3
- Size = 1/2" W x 1/4" H
- Minimum Bend Radius = 1 1/8"
- Minimum Install Temperature
  - -40°F (-40°C)
- Cut to Length and terminate in the field
- Can be overlapped without burnout

## POWER OUTPUT CURVES

Power Output Curves shown below apply to cables used at service voltages shown below on insulated metal pipes. For other applications contact Indeco.

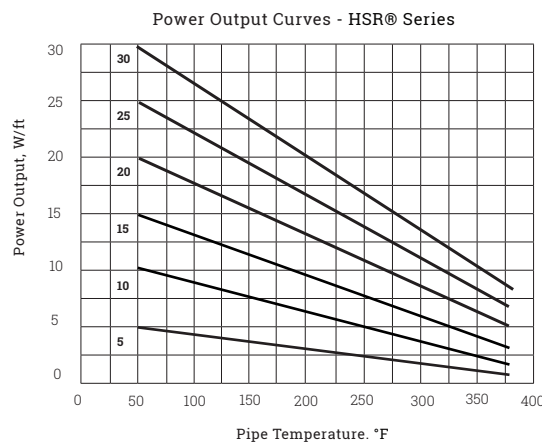

Power Adjustment Factor		
Model	208 Volts	277 Volts
HSR05-2	0.85	1.17
HSR10-2	0.88	1.14
HSR15-2	0.91	1.11
HSR20-2	0.94	1.08
HSR25-2	0.96	1.04
HSR30-2	0.99	1.01

## CONNECTION ACCESSORIES

All Cables require power connection and end seal terminations as a minimum to comply with third party requirements. Indeco offers accessories to provide trouble free easy installation and maximum cable circuit life.

## CONSTRUCTION

- 16 AWG Nickel Plated Copper Buss Wires
- Modified Fluoropolymer heater core
- Modified Fluoropolymer insulating jacket
- Tinned Copper Braid
- Fluoropolymer Outer Jacket
  - Protects against organic, inorganic and corrosive chemicals



Accessories - Ordinary Area / Div 2 Hazardous Area			
Type	Ord Area	Div 2	Model
Power Connection	x	x	PCA-81J
Pipe Stand Off Kit	x	x	PCA-81P
Splice/Tee Connection	x	x	SPTA-1
End Seal	x	x	ESA-81
Lighted End Seal 120 V	x	x	LESA-1
Lighted End Seal 208-240V	x	x	LESA-2
Thermostat - Ambient Sense	x		HTTS-A
Thermostat - Line Sense	x		HTTS-L
Thermostat - Ambient Sense	x	x	HTTS-EPA
Thermostat - Line Sense	x	x	HTTS-EPL
Application Tape	x	x	HTFT-1
Aluminum Foil Tape	x	x	HTAT-1
6 inch Pipe Strap	x	x	HTPS-6
10 Inch Pipe Strap	x	x	HTPS-10
Caution Label	x	x	HTCL-1

## CIRCUIT BREAKER SIZING

Maximum Circuit Lengths per start up temperature and circuit breaker size are shown below. Use local electrical codes to select appropriate branch circuit breakers. Ground Fault circuit breakers are required for heat trace branch circuits – typical minimum trip level is 30mA. Thermal magnetic circuit breakers are recommended to reduce nuisance tripping.

**Maximum Circuit Length vs Breaker Size & Start-Up Temp FT (M)**

Model	Start-Up Temperature		15 A	20 A	30 A	40 A
	Deg F	Deg C				
HSR5-1	50 (10)		180 (55)	240 (73)	335 (102)	350 (107)
	0 (-20)		165 (50)	220 (67)	330 (101)	350 (107)
	-50 (-45)		150 (46)	200 (61)	300 (91)	350 (107)
HSR5-2	50 (10)		360 (110)	480 (146)	540 (165)	680 (299)
	0 (-20)		325 (99)	430 (131)	540 (165)	680 (299)
	-50 (-45)		290 (88)	385 (117)	540 (165)	680 (299)
HSR10-1	50 (10)		120 (37)	160 (49)	180 (55)	240 (73)
	0 (-20)		105 (32)	140 (43)	180 (55)	220 (67)
	-50 (-45)		90 (27)	120 (37)	180 (55)	220 (67)
HSR10-2	50 (10)		240 (73)	320 (98)	360 (110)	470 (143)
	0 (-20)		230 (70)	305 (93)	360 (110)	470 (143)
	-50 (-45)		225 (69)	300 (91)	360 (110)	450 (137)
HSR15-1	50 (10)		80 (24)	105 (32)	135 (41)	180 (55)
	0 (-20)		70 (21)	90 (27)	135 (41)	160 (49)
	-50 (-45)		60 (18)	80 (24)	120 (37)	135 (41)
HSR15-2	50 (10)		160 (49)	210 (64)	270 (82)	350 (107)
	0 (-20)		140 (43)	185 (56)	270 (82)	340 (104)
	-50 (-45)		120 (37)	160 (49)	240 (73)	300 (91)
HSR20-1	50 (10)		60 (18)	90 (27)	120 (37)	120 (37)
	0 (-18)		55 (17)	70 (21)	110 (34)	110 (34)
	-50 (-45)		50 (15)	65 (20)	100 (30)	100 (30)
HSR20-2	50 (10)		115 (35)	150 (46)	230 (70)	230 (70)
	0 (-18)		110 (34)	145 (44)	220 (67)	220 (67)
	-50 (-45)		105 (32)	140 (43)	210 (64)	210 (64)
HSR25-1	50 (10)		45 (14)	60 (18)	85 (26)	85 (26)
	0 (-18)		40 (12)	50 (15)	80 (24)	80 (24)
	-50 (-45)		40 (12)	50 (15)	80 (24)	80 (24)
HSR25-2	50 (10)		90 (27)	120 (37)	170 (52)	170 (52)
	0 (-18)		80 (24)	100 (30)	160 (49)	160 (49)
	-50 (-45)		80 (24)	100 (30)	160 (49)	160 (49)
HSR30-1	50 (10)		40 (12)	50 (15)	70 (21)	70 (21)
	0 (-18)		35 (11)	45 (14)	70 (21)	70 (21)
	-50 (-45)		35 (11)	45 (14)	70 (21)	70 (21)
HSR30-2	50 (10)		80 (24)	100 (30)	140 (43)	140 (43)
	0 (-18)		70 (21)	90 (27)	140 (43)	140 (43)
	-50 (-45)		70 (21)	90 (27)	140 (43)	140 (43)

Note – Circuit lengths shown above are based on trip current characteristics of Type QO and Type QOB devices. For equipment with different trip current characteristics please consult Indeco.

## PRODUCT ORDERING INFORMATION

Ordering Information				
Output W/ft	Volts	Model	Stock	LBS/1000'
5 W/FT @ 50F	120	HSR05-11T00	S	90
	208-277	HSR05-21T00	S	90
10 W/FT @ 50F	120	HSR10-11T00	S	90
	208-277	HSR10-21T00	S	90
15 W/FT @ 50F	120	HSR15-11T00	S	90
	208-277	HSR15-21T00	S	90
20 W/FT @ 50F	120	HSR20-11T00	S	90
	208-277	HSR20-21T00	S	90
25 W/FT @ 50F	120	HSR25-11T00	S	90
	208-277	HSR25-21T00	S	90
30 W/FT @ 50F	120	HSR30-11T00	S	90
	208-277	HSR30-21T00	S	90

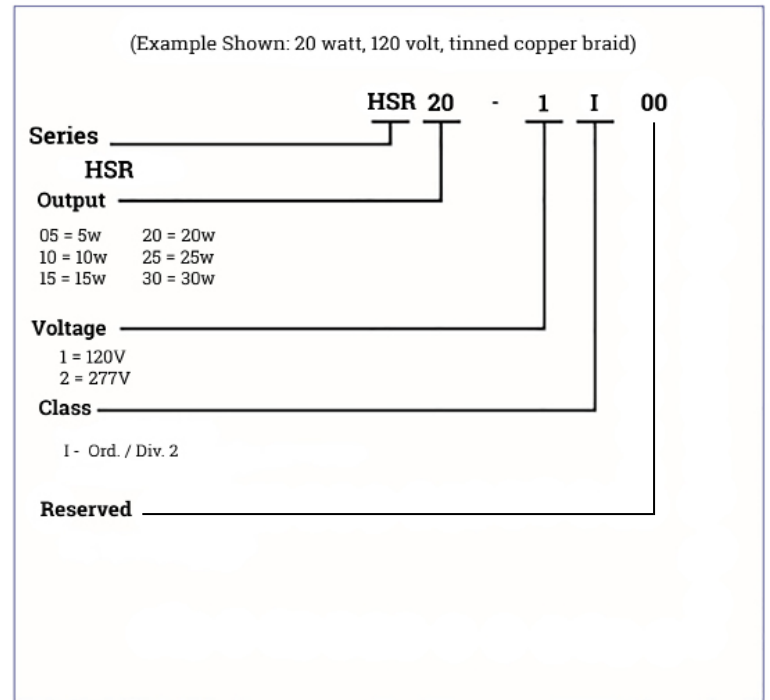

Note = To order specify model, length, and connection accessories. Cables are shipped +/- 5% of label, maximum spool length 1000 feet, minimum order is 250 feet. No fee to cut to length between 250 and 1000 feet.

# TYPE MIHT K & B INCOLOY SHEATH HEATING CABLE

Indeeco Mineral Insulated type K & B heating cable is ideal for a wide range of industrial and commercial heating applications. It has resistive heating conductors embedded in highly compressed magnesium oxide insulation and covered with a stainless Alloy 825 sheath. The sheath is fully annealed and is easily hand formable. The low resistance metallic sheath is an ideal ground path. MI heating cable is totally inorganic and will not deteriorate with age. All heating units are factory fabricated to a specified length and rigorously tested to IEEE standards.

## APPLICATIONS

- Process Pipe Heating
- Freeze Protection
- Snow Melting
- Frost Heave Protection
- Tank & Vessel Heating
- Up to 1100°F Exposure Temps.

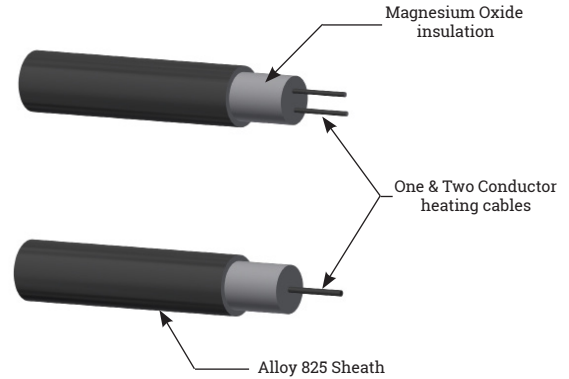

## TYPE MIHT HEATING CABLE SPECIFICATIONS

Table 1

300 Volt, 2 Conductor 3/16" OD .07 lbs/ft			600 Volt, 2 Conductor 5/16" OD .22 lbs/ft			600 Volt, 1 Conductor 3/16" OD .07 lbs/ft		
Size	Ohms/ft	Max Exp Temp °F	Size	Ohms/ft	Max Exp Temp °F	Size	Ohms/ft	Max Exp Temp °F
K556	.043*	600	B588	.0071*	600	K145	.0046*	600
K658	.058*		B614	.0149*		K189	.0090*	
K674	.074*		B627	.027*		K216	.0165*	
K693	.093*		B640	.040*		K239	.039	
K712	.117*		B670	.065		K250	.050	
K715	.147*		B710	.104		K279	.079	
K721	.213*		B715	.162		K310	.095	
K732	.319		B720	.205		K316	.157	
K742	.416	B732	.325	K326	.260	1100		
K752	.520	B750	.500	K333	.330			
K766	.660	B774	.735	K346	.457			
K774	.740	B810	1.162	K372	.730			
K810	1.00	B819	1.87	K412	1.17			
K813	1.30	B830	2.97	K415	1.48			
K818	1.80	B840	4.30	K423	2.36			
K824	2.34	B859	5.98	K430	2.80			
K830	2.96			K447	4.50			
K838	3.70							
K846	4.72							
K860	5.60							
K866	6.60							
K894	9.00							
K919	18.00							

Note: All values @ 68° F  
 \* Resistance curves apply, consult factory for design

# HEATER FORMS

Table 2

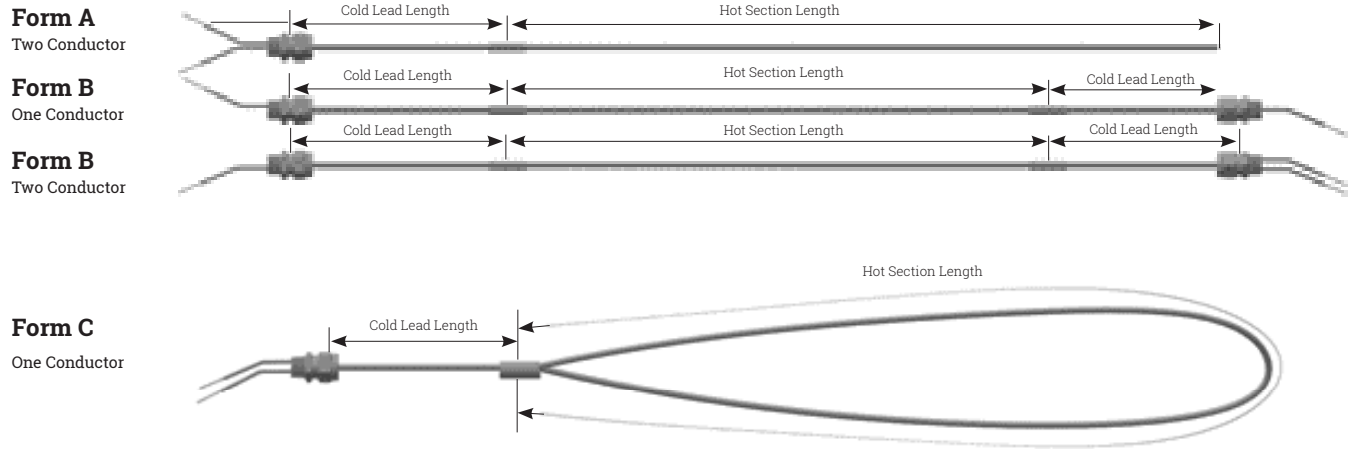

# SPECIAL FEATURES

Table 3

Option	Description
-C1	1 /2" reversed gland on hot to cold joint.
-C2	3/4" reversed gland on hot to cold joint.
-E	Puller eye end cap.
-P	P.V.C.jacketed cold section
-Q	High temperature adapter
-R	Heater on non-returnable reel
-U	Listed NEMA 7 termination fitting
-X	Other, specify

# HEATER CATALOG NUMBER SYSTEM

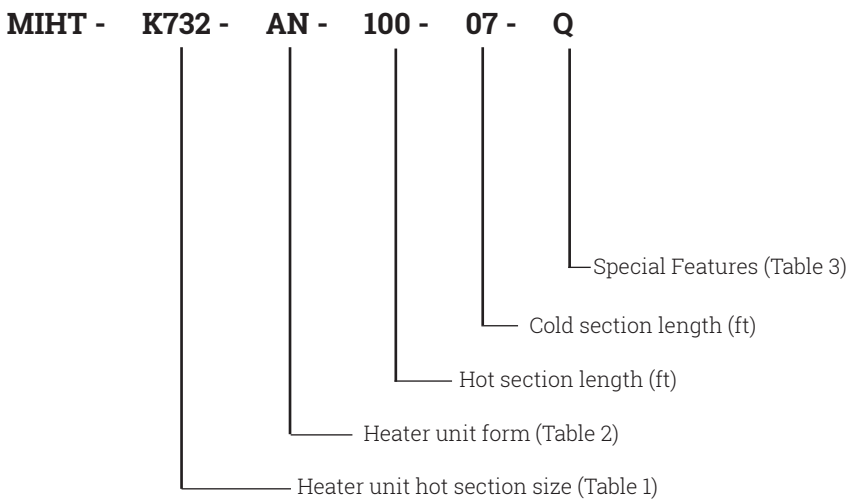



425 Hanley Industrial Court  
St. Louis, MO 63144  
Ph: 314-644-4300 – Fax: 314-644-5332  
www.indeeco.com

Date \_\_\_\_\_ Job Reference \_\_\_\_\_  
Company Name \_\_\_\_\_  
Address \_\_\_\_\_  
City \_\_\_\_\_ State \_\_\_\_\_ Zip \_\_\_\_\_  
Customer Contact \_\_\_\_\_  
Phone No. \_\_\_\_\_  
E-Mail Address \_\_\_\_\_  
Site Delivery Requirement: \_\_\_\_\_

## Heat Trace

Download the form and fill out all known information. Once complete, email to [HeatTraceOrders@spx.com](mailto:HeatTraceOrders@spx.com)

### INSTALLATION INFORMATION:

Site Low Ambient Temperature: \_\_\_\_\_  
Site High Ambient Temperature: \_\_\_\_\_  
Overall Quantity: \_\_\_\_\_  
Individual Lengths Required (if applicable): \_\_\_\_\_

### HEAT TRACE DATA

Pipe Diameter: _____	Pipe Type (metal/plastic): _____
Pipe length: _____	Insulation Type: _____
Insulation Thickness: _____	Indoor / Outdoor Location: _____
Maintain Temperature: _____	Minimum Ambient Temperature: _____
Maximum Exposure Temperature: _____	Operating Voltage (120,208,240,277): _____
Line Sensing Control: _____	Ambient Sensing Control: _____
Hazardous Area / Class & Division: _____	Hazardous Area T-Rating: _____
# of valves in line (if known): _____	# of flanges in line (if known): _____
# of pipe supports in line (if known): _____	# of tees in line (if known): _____

### CONTROL METHOD (IF APPLICABLE)

Line Sensing Thermostat: \_\_\_\_\_ Electronic Controller: \_\_\_\_\_

### SPECIAL NOTES:

## Inspection Report Form for Electric Heat Tracing (Typical)

Location: _____	System: _____	Reference Drawing(s): _____
-----------------	---------------	-----------------------------

### CIRCUIT INFORMATION

Heater Cat. No.: _____	Circuit Length: _____	Bkr. Panel No.: _____
Power Connection: _____	Design Voltage: _____	Bkr. Pole(s) No.: _____
Tee Connection: _____	Ground-Fault Protection (type): _____	
Splice Connection: _____	Ground-Fault Trip Setting: _____	
Heater Control: _____	Operating Voltage: 120    208    240    277	

### VISUAL

Panel Number	Circuit #					
	Date					
	Initial					
<b>Thermal Insulation</b>						
Damaged Insulation / Lagging						
Water Seal Good						
Insulation / Lagging Missing						
Presence of Moisture						
<b>Heating System Components</b>						
Enclosures, Boxes Sealed						
Presence of Moisture						
Sign of Corrosion						
Heater Lead Discoloration						
<b>Heating and/or High Limit Controller</b>						
Operating Properly						
Controller Setpoint						

### ELECTRICAL

<b>Dielectric Insulation Resistance (Bypass Controller) Refer to IEEE-2017 for test voltages and pass/fail criteria</b>						
Test Voltage						
Megger Value						
<b>Heater Supply Voltage</b>						
Value at Power Source						
Value at Field Connection						
<b>Heater Circuit Current Reading</b>						
Pipe Temperature						
Amps Reading at 2-5 min.						
Amps Reading After 15 min.						
Ground-Fault Current						
<b>Comments and Actions:</b>						
Performed by:	Company:	Date:				
Approved by:	Company:	Date:				

We have the experience and expertise to provide you with the personalized support to arrive at customized solutions.

Email [sales@indeeco.com](mailto:sales@indeeco.com)  
or call 800.243.8162  
to find your nearest  
Indeeco representative.

